

**Salsco, INC.**  
LEADER BY DESIGN

MADE IN THE U.S.A

## OPERATORS AND PARTS MANUAL MODEL 624 PTO CHIPPER



rev. 6/06

---

MANUFACTURER OF OUTDOOR POWER EQUIPMENT

Products for Turf & Lawn care, Rental, Construction, Tree care, Wood Processing, Nursery & Farm Industries

*Other Salsco Equipment*

**Mini-Track Paver - Cobra Curber - Scorpion Pavement Router**  
**3-1/2" - 18", Gas, Diesel, and P.T.O, Wood/Brush Chippers**  
**Chipper Shredder Vacuum - Tailgate & Truckloader Vacuums up to 65 HP**

***Quality of Workmanship, Innovative  
Design, Built to Last!***

105 School House Road  
Cheshire, CT 06410 U.S.A.  
800-872-5726, 203-271-1682, 203-271-2596 (Fax)  
sales@salsco.com, www.salsco.com

**TABLE OF CONTENTS**  
**MODEL 624PTO CHIPPER**

COVER & TABLE OF CONTENTS.....Pages 1 – 2

STATEMENT OF FACT ..... Page 3

MACHINE REGISTRATION .....Page 4

ANSI SAFETY & OPERATING INSTRUCTIONS .....Pages 5 - 6

HOW TO CUT A DRIVE SHAFT.....Page 7

CAUTIONS.....Page 8

PARTS DIAGRAMS ..... Pages 9 – 11

SERVICE SCHEDULE.....Page 12

TORQUE CHARTS .....Page 13

WARRANTY POLICY/PROCEDURE .....Page 14

COPYOF WARRANTY CLAIM FORM.....Page 15

SERVICE SCHEDULE LOG .....Page 16

SALSCO, INC.  
105 School House Road  
Cheshire, CT 06410  
800-872-5726, 203-271-1682  
203-271-2596 (Fax)  
[www.salsco.com](http://www.salsco.com), [sales@salsco.com](mailto:sales@salsco.com)

## **STATEMENT OF FACT**

You have just purchased the highest quality, most dependable, PTO Chipper on the market today. This unit has the ability to meet exact standards and perform for years with minimum downtime. HOWEVER, it cannot read nor will it understand this manual no matter how long you leave it on top of the machine.

**It is your responsibility** to read and understand this manual; it is also your responsibility to be certain this information is passed along to anyone who is expected to operate this equipment. Should you choose not to read, understand and pass along the information provided you, please expect equipment failure and possible injuries to persons around this equipment.

For the safety of the operator, it is **imperative** that this manual is carefully read and understood.

Once you have read this manual, it is your responsibility to be sure that all new operators read and understand this manual, especially all cautions stated.

As a manufacturer of equipment, we have a responsibility to design a safe piece of equipment. NOTE: The important safeguards and instructions in this manual are not meant to cover all possible conditions and situations that may occur. It must be understood that common sense, caution, and care are factors, which cannot be built into any product. These factors must be supplied by the person(s) caring for and operating this equipment.

**ONLY YOU CAN PREVENT ACCIDENTS!!**

**MACHINE REGISTRATION**

MANUFACTURED BY: SALSCO, INC.  
105 School House Rd., Cheshire, CT 06410  
800-872-5726, 203-271-1682, 203-271-2596 (Fax)  
[sales@salsco.com](mailto:sales@salsco.com) [www.salsco.com](http://www.salsco.com)

THIS MANUAL COVERS MODEL (s): Model 624PTO, Chipper

This company reserves the right to discontinue, add improvements to, or change the design of any model or product at any time without obligation to improve existing machines, either by changing the design or adding new parts.

It has been and will continue to be the policy of SALSCO to update existing machines at its own discretion. Whenever possible, new designs will be made in such a way that they can be "Retro Fit" if so desired.

Record in the space provided below the model and serial number of this unit. Please retain these numbers for future reference.

No parts orders will be accepted **WITHOUT MODEL NUMBERS OR PART NUMBERS**. All part numbers are listed in this manual.

\_\_\_\_\_

Serial Number

\_\_\_\_\_

Model Number

NOTE: Be sure to complete your warranty card. This will insure immediate processing of any warranty claims.

**READ AND UNDERSTAND THIS MANUAL BEFORE STARTING THE MACHINE**

1/06

## **BRUSH CHIPPERS ANSI Z133.1-2006**

### **American National Standard for Arboricultural Operations Safety Requirements**

#### **5.3 Brush Chippers**

- 5.3.1 The items contained in section 5.1 shall always be included in the review of this section.
- 5.3.2 Access panels (for example, guards) for maintenance and adjustment, including discharge chute and cutter housing, shall be closed and secured prior to starting the engine of brush chippers. These access panels shall not be opened or unsecured until the engine and all moving parts have come to a complete stop (see Annex C, General Safety Procedures That Apply to All Tree Work).
- 5.3.3 Rotary drum or disc brush chippers not equipped with a mechanical infeed system shall be equipped with an infeed hopper not less than 85 inches (2.15 m) measured from the blades or knives to ground level over the center line of the hopper. Side members of the infeed hopper shall have sufficient height so as to prevent workers from contacting the blades or knives during operations.
- 5.3.4 Rotary drum or disc brush chippers not equipped with a mechanical infeed system shall have a flexible anti-kickback device installed in the infeed hopper to reduce the risk of injury from flying chips and debris.
- 5.3.5 Chippers equipped with a mechanical infeed system shall have a quick-stop and reversing device on the infeed system. The activating mechanism for the quick-stop and reversing device shall be located across the top, along each side, and close to the feed end of the infeed hopper within easy reach of the worker.
- 5.3.6 Vision, hearing, and/or other appropriate personal protective equipment shall be worn when in the immediate area of a brush chipper in accordance with section 3.4, Personal Protective Equipment.
- 5.3.7 Arborists, mechanics, and other workers shall not, under any circumstances, reach into the infeed hopper when the cutter disc, rotary drum, or feed rollers are moving.
- 5.3.8 When trailer chippers are detached from the vehicles, they shall be chocked or otherwise secured in place.
- 5.3.9 When in a towing position, chipper safety chains shall be crossed under the tongue of the chipper and properly affixed to the towing vehicle.
- 5.3.10 See section 8.6, Brush Removal and Chipping, for additional requirements.

## **BRUSH REMOVAL AND CHIPPING ANSI Z133.1-2006**

### **American National Standard for Arboricultural Operations Safety Requirements**

#### **8.6 Brush Removal and Chipping**

- 8.6.1 Traffic control around the jobsite shall be established prior to the start of chipping operations along roads and highways (see section 3.2, Traffic Control Around the Jobsite).
- 8.6.2 Brush and logs shall not be allowed to create hazards in the work areas.
- 8.6.3 To prevent an entanglement hazard, loose clothing, climbing equipment, body belts, harnesses, lanyards, or gauntlet-type gloves (for example, long-cuffed lineman's or welder's gloves) shall not be worn while operating chippers.
- 8.6.4 Personal protective equipment shall be worn when in the immediate area of chipping operations in accordance with section 3.4, Personal Protective Equipment, of this standard.
- 8.6.5 Training shall be provided in the proper operation, feeding, starting, and shutdown procedures for the chipper being used.
- 8.6.6 Maintenance shall be performed only by those persons authorized by the employer and trained to perform such operations.
- 8.6.7 Brush and logs shall be fed into chippers, butt or cut end first, from the side of the feed table center line, and the operator shall immediately turn away from the feed table when the brush is taken into the rotor or feed rollers. Chippers should be fed from the curb-side whenever practical.
- 8.6.8 The brush chipper discharge chute or cutter housing cover shall not be raised or removed while any part of the chipper is turning or moving. Chippers shall not be used unless a discharge chute of sufficient length or design is provided that prevents personal contact with the blades (see Annex C, General Safety Procedures That Apply to All Tree Work).
- 8.6.9 Foreign material, such as stones, nails, sweepings, and rakings, shall not be fed into chippers.
- 8.6.10 Small branches shall be fed into chippers with longer branches or by being pushed with a long stick.
- 8.6.11 Hands or other parts of the body shall not be placed into the infeed hopper. Leaning into or pushing material into infeed hoppers with feet is prohibited.
- 8.6.12 While material is being fed into the chipper infeed hopper chute, pinch points continually develop within the material being chipped and between the material and machine. The operator shall be aware of this situation and respond accordingly.
- 8.6.13 When feeding a chipper during roadside operations, the operator shall do so in a manner that prevents him or her from stepping into traffic or being pushed into traffic by the material that is being fed into the chipper.
- 8.6.14 When using a winch in chipper operations, the operator shall ensure that the winch cable is properly stored before initiating chipper operations.
- 8.6.15 Refer to section 5.3, Brush Chippers, for additional information.

## HOW TO CUT A DRIVE SHAFT

- 1) Attach the implement to the tractor. Raise and lower it, **BE SURE** it's angle is correct and there is nothing hitting.
- 2) Raise and lower till the stub PTO shaft on the tractor and the implement are the closest to each other they can be.
- 3) Take a measurement **TIP TO TIP** on the stub shafts. **EXAMPLE:** Let's say 28" tip to tip is the measurement you made.
- 4) Lay the drive shaft on the bench. Close it **ALL THE WAY** and measure from inside of each yoke to the other. Don't forget the yoke must fit over the stub shaft. That's why you measure from inside the yoke. **EXAMPLE:** Let's say the drive shaft is 60" from yoke to yoke when it's in its most closed state.

28" is what we want!

60" is what we have!

Take 60"- 28" = 32" from each side

THAT'S THE AMOUNT THAT SHOULD BE CUT FROM EACH HALF OF THE DRIVE SHAFT.

- 5) **NOTES:** To remember

- A - **DON'T** forget the yoke must fit over the stub shaft.
- B - You can cut it again **EASIER** than you can add.

**SAFETY FIRST – ALWAYS WEAR PROTECTIVE  
GEAR WHEN WORKING WITH/ON,  
EQUIPMENT/TOOLS!**

## CAUTIONS

READ THOROUGHLY THE OPERATOR SAFETY INSTRUCTIONS ON THE FOLLOWING THREE PAGES, WHICH ARE THE AMERICAN NATIONAL STANDARD OF POWERED SHREDDERS/GRINDERS, SAFETY SPECIFICATIONS PROVIDED BY ANSI AND THE O.P.E.I.

THE FOLLOWING CAUTIONS ARE PROVIDED BY SALSCO AS A QUICK REFERENCE ONLY AND ARE NOT MEANT TO REPLACE THE PRECAUTIONS ON THE FOLLOWING PAGES.

1. **ALWAYS** use protective eyewear when machine is in operation.
2. **ALWAYS** use gloves and wear ear protection when machine is in operation.
3. **NEVER** put hands, legs or any part of your body into or near Chipper intake or discharge openings.
4. **NEVER** run machine with guards or shaft cover removed.
5. **ALWAYS** allow machine to cool off, **BE SURE** machine has stopped completely, and disconnect drive shaft from tractor before attempting any maintenance, or repair.
6. **NEVER** stand in front of chipper infeed hopper. It is possible for a chip or piece of wood to be thrown out.
7. **BE SURE** the machine and tractor is parked on a dry level surface before starting operation.
8. **DO NOT** operate with loose clothing or long unrestrained hair. Be sure vines and branches are not wrapped around your body parts.
9. **DO NOT** operate on ice or any other slippery surface. Be sure area around machine is clear and clean. You do not want to trip into the machine.
10. **NEVER** leave machine running unattended, especially around youngsters or persons not instructed in the safe operation of this machine.
11. **READ** and understand federal guidelines provided with this manual.

**NEVER** run machine without connecting the 3-point to the tractor!

REV	DESCRIPTION	DATE

ISSUED: 08-20-2007

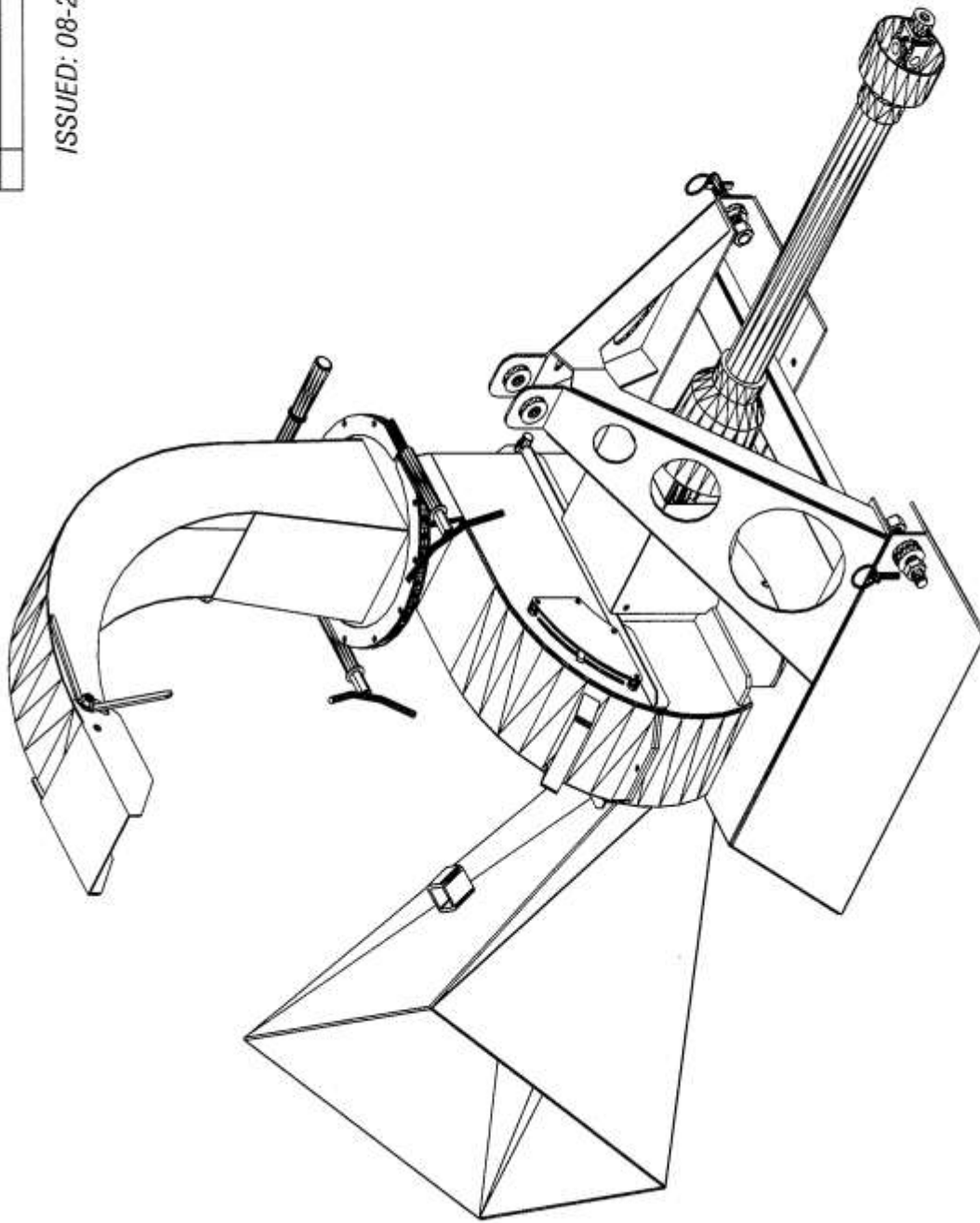

CHIPPER MODEL 624 PTO  
MAIN ASSEMBLY - DWG #1

REV.	REVISION	DATE

DATED: 08-20-2007

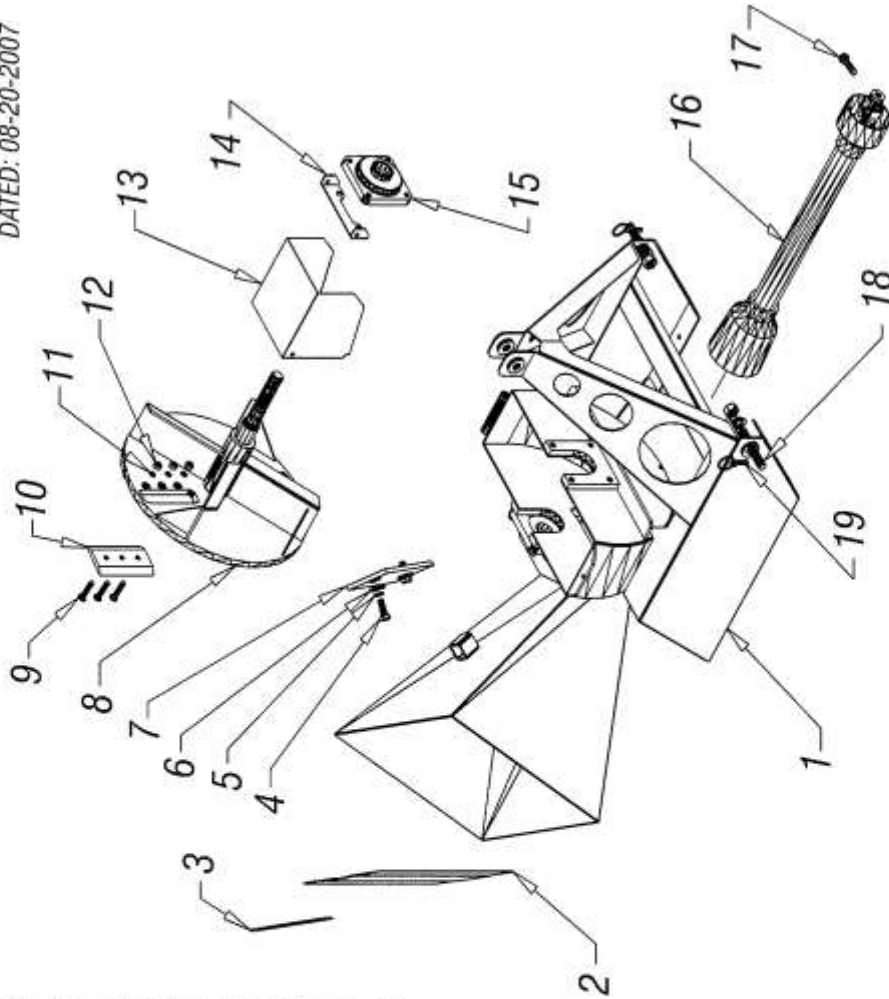

ITEM	PART DESCRIPTION	PART #	QTY
1	HOUSING, IMPELLER- LOWER	0228254	1
2	GUARD, CLEAR VINYL STRIP	0421429	3
3	PLT, DEBRIS GUARD BACKING	0462376	1
4	BOLT, HEX HEAD	0346535	2
5	LOCK WASHER	0353014	2
6	FLAT WASHER	0353110	2
7	BLADE, BED KNIFE	0405136	1
8	SHAFT / IMPELLER	0248236	1
9	FLAT HD SOC CAP SCREW	0346486	6
10	BLADE, CHIPPER, DBL EDGE	0305047	2
11	LOCK WASHER	0353017	6
12	NUT, STOVER	0338154	6
13	GUARD, SHAFT / IMPELLER	0421428	1
14	BRKT, SHAFT GUARD MTG	0406779	1
15	BEARING, 4-BOLT, FLANGED	0303059	2
16	DRIVE SHAFT, COMPLETE	0348242	1
17	SHEAR BOLT	0346887	1
18	DRAW PIN	0340106	2
19	LYNCH PIN	0340102	2

CHIPPER MODEL 624 PTO  
CHIPPER COMPONENTS - DWG #2

REV.	DESCRIPTION	DATE

ISSUED : 08-20-2007

ITEM	PART DESCRIPTION	PART#	QTY
1	PIN, IMPEL. HOUSING HINGE	0240117	1
2	HOUSING, IMPELLER-UPPER	0228255	1
3	CLAMP, EXHT CHUTE-FRONT	0210147	1
4	CLAMP, EXHT CHUTE-REAR	0210148	1
5	WING NUT, EXHAUST CLAMP	0238504	2
6	WING NUT, CHUTE DEFLECTOR	0238500	1
7	CHUTE DEFLECTOR	0439799	1
8	CHUTE, EXHAUST	0226147	1
9	RUBBER GRIP	0332009	2

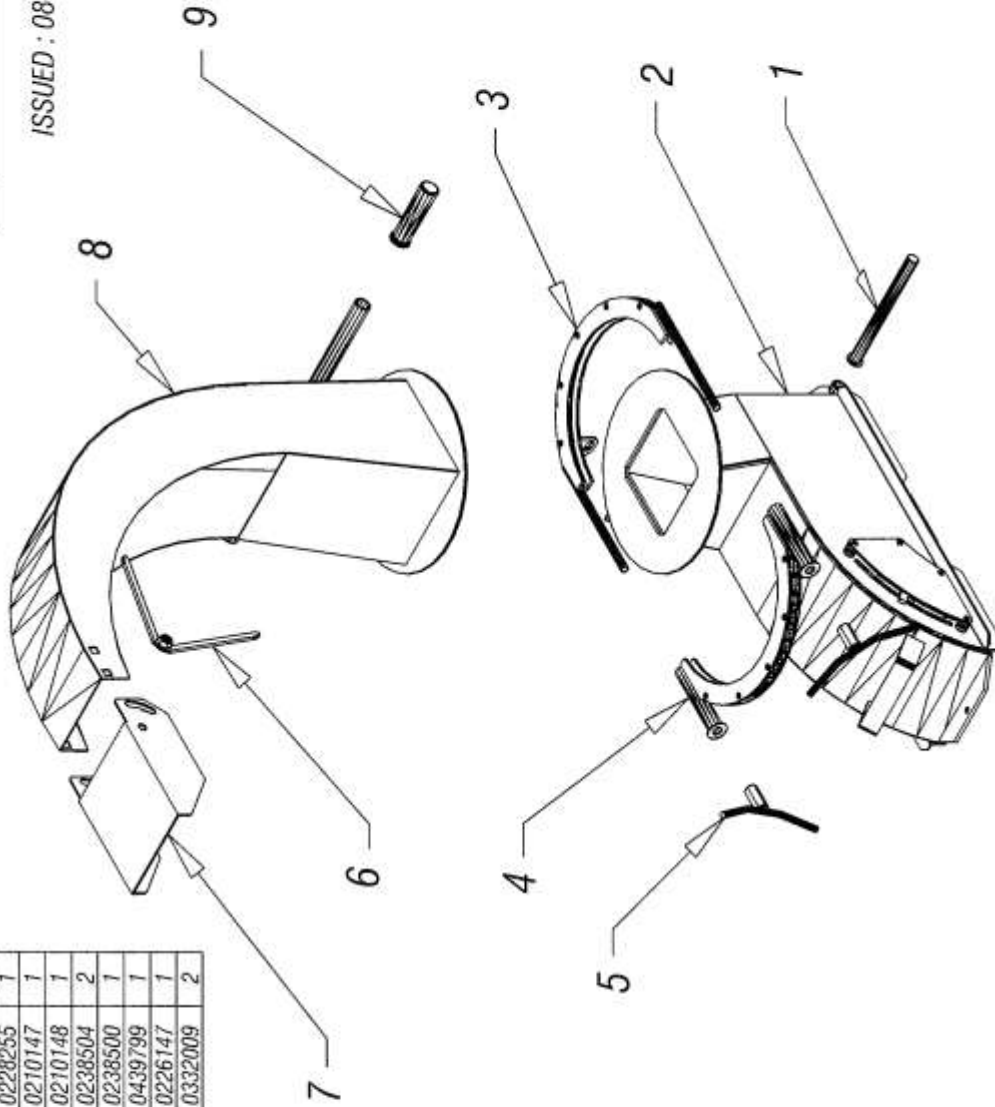

CHIPPER MODEL 624 PTO  
CHIPPER COMPONENTS - DWG #3

**624 PTO  
SERVICE SCHEDULE**

1. Whenever service is to be done to a PTO implement, be sure to disconnect the drive shaft.
2. **GREASE** all bearings daily. **DO NOT OVER GREASE.** Wipe extra grease off bearings.
3. **To sharpen blades:** Remove hopper or open door (depending on which model machine). Remove blades and replace with sharpened ones. It is recommended that you replace the hardware whenever replacing blades. Be sure to follow the torque specifications in your manual. Be sure to clean mounting surface before bolting on new blades. Be sure to use Loctite when replacing hardware.
4. **Bed knife adjustment:** This adjustment varies from 1/16" to 1/4". The larger the opening, between bed knife and chip blades, the faster the wood will feed and the harder the machine will have to work. The smaller the opening, the slower it will feed and the less work the machine will have to do. We recommend 1/8" to 3/16".
5. Be sure you double-check all nuts and bolts for tightness. A loose bolt can cause total destruction of the machine.
6. Keep machine clean and free from dirt.

SERVICE SCHEDULE	AS NEEDED	DAILY	WEEKLY
CLEAN MACHINE	X	X	
GREASE DISC SHAFT BEARING	X	X	
SHARPEN CHIPPER BLADES	X OR		X
CHECK & ADJUST BED KNIFE	X OR		X
CHECK ALL NUTS & BOLTS	X	X	

**NEVER, UNDER ANY CIRCUMSTANCES, RUN THE WHEN UNIT IT IS OPEN  
OR AT ANY TIME DURING SERVICE OR ROUTINE MAINTENANCE.**

Below is a quick reference chart for various “Flat Head Cap Screws” and the torque recommendations.

**VALUES ARE STATED IN FOOT POUNDS**

BOLT SIZE	Thds Per Inch	SAE Grade 5	SAE Grade 8
1/4	20	10	14
	28	---	---
5/16	18	19	29
	24	---	---
3/8	16	33	47
	24	---	---
7/16	14	54	78
	20	---	---
1/2	13	78	119
	20	---	---
9/16	12	114	169
	18	---	---
5/8	11	154	230
	11	---	---
3/4	10	257	380
	10	---	---
7/8	9	382	600
	9	---	---
1	8	587	700
	8	---	---

Drive Belt Tension Measurement by Deflection

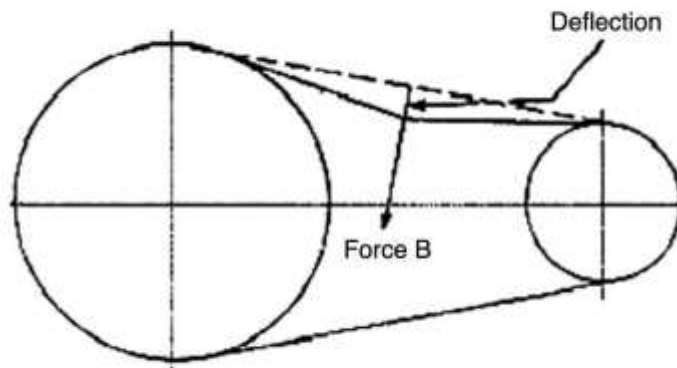

Deflection should be 3/8" when 8-12 lbs. push is applied at "B"

# WARRANTY POLICY

Please remember to complete and return your Warranty Card and Dealer Delivery Report. Warranty Claims will not be considered if the Warranty Card and Dealer Delivery Report have not been returned to Salsco.

Your Salsco Commercial or Turf Equipment product is a commercial type product and is normally manufactured and sold for commercial or industrial use. **Salsco will, for the original purchaser, for one (1) year from the date of purchase (90 days if used for rental purposes) repair or replace, free of charge, any SALSCO part or parts found to be defective in material, workmanship or both.** Any transportation or shipping charges will be borne by the purchaser. If, during the warranty period stated above, the product does not function properly due to defect, simply contact Salsco and follow the Warranty Procedures included in this manual.

This warranty **does not** include:

- Incidental or consequential damages and is exclusive of any implied warranties.
- Normal maintenance parts, including, but not limited to hoses, chains, belts, filters, lubricants, etc.
- Parts or components, which are covered under the original manufacturer warranty, including, but not limited to engines, pumps, and motors.

## WARRANTY PROCEDURE

In order for Salsco to consider your warranty claims in a timely manner you must follow the simple procedures listed below:

### MACHINE OR PART FAILURE

- Call our service department for helpful instruction on how to correct or repair the problem. Preventive maintenance will also be suggested.
- When ordering parts for Warranty issues, you **MUST** retain possession of the old parts in question until notified with respect to returning the parts to Salsco or other disposition.
- Warranty Claims **MUST** be filed within 30-days from completion of the work performed. Contact our office for an electronic warranty claim form.
- Fill in all information requested on warranty claim form, a copy of which is included in this manual, (date of purchase, company name, address, etc.). List all parts used. Make sure part numbers are correct. You can obtain these from your manual. (include good description of problem; i.e. "leaking from spool" rather than "leaking").
- It is our goal to consider and reach a disposition on each Warranty Claim within 30-days from the date that it is received. Therefore it is important that you respond promptly to any request for further information. Claims with no response to inquiries will be closed as "**denied for lack of response**" 90-days from the date of request.
- Email, Fax or Send Warranty Claim form to our Warranty Department. – **Warranty on parts most often requires return of the parts that were replaced. DO NOT DISCARD OLD PARTS UNTIL YOU HAVE RECEIVED A DETERMINATION AS TO WHETHER THESE PARTS MUST BE RETURNED.**
- Our Warranty Department will contact and instruct you on how to return the Parts to Salsco on an RA #. Returns **MUST** be made within 30-Days from issuance of RA #. **FREIGHT CHARGES ON RETURN OF PARTS IS THE RESPONSIBILITY OF THE CUSTOMER.** Normal pre-delivery adjustments are not covered under warranty. Labor Warranties are based on reasonable time allowances as determined by Salsco, Inc. and paid at 75% of posted labor rate. **TRAVEL TIME IS NOT REIMBURSED UNDER THE WARRANTY POLICY.**
- Be sure to put the RA form inside the box that you are shipping back, also be sure to put on the outside of the box "Return of Goods" and the RA #.
- Ship returns via a traceable method such as UPS Ground Service. Be sure that the shipment is insured for the appropriate value. If uninsured parts are lost, we cannot issue a credit.

**PLEASE NOTE:**     *Warranty forms should be filled out completely.*

**PREVENTIVE MAINTENANCE IS YOUR BEST INSURANCE AGAINST EQUIPMENT FAILURE. BE SURE TO READ THIS MANUAL, ESPECIALLY THE MAINTENANCE, OPERATING AND CAUTION SECTIONS.**

SALSCO, INC., 105 School House Rd.  
Cheshire, CT 06410  
800-872-5726, 203-271-1682  
203-271-2596 (Fax)  
sales@salsco.com, [www.salsco.com](http://www.salsco.com)





SALSCO, INC.