

OPERATORS AND PARTS MANUAL

MODEL 627XT PTO CHIPPER



MANUFACTURER OF OUTDOOR POWER EQUIPMENT

Products for Turf & Lawncare, Rental Construction, Tree Care, Wood Processing, Nursery & Farm Industries

Other Salsco Equipment:

3-1/2" - 18", Gas, Diesel, and P.T.O. Wood/Brush Chippers

Chipper Shredder Vacuum - Tailgate & Truckloader Vacuums, Strawblowers, Slicer Seeders

Shaving Mills - Gas & Electric Greens Rollers

***Quality of Workmanship, Innovative
Design, Built to Last!***

105 School House Road
Cheshire, CT 06410 U.S.A.
800-872-5726, 203-271-1682, 203-271-2596 (Fax)
sales@salsco.com, www.salsco.com

TABLE OF CONTENTS
MODEL 627XT CHIPPER

COVER & TABLE OF CONTENTS.....Pages 1 – 2

STATEMENT OF FACT Page 3

SPECIFICATIONS & FEATURESPage 4

MACHINE REGISTRATIONPage 5

ANSI SAFETY & OPERATING INSTRUCTIONSPages 6 – 7

CAUTIONS.....Page 8

HOW TO CUT A DRIVE SHAFTPage 9

SERVICE /MAINTENANCE.....Page 10

OPERATING INSTRUCTIONSPage 11

PARTS DIAGRAMSPages 12 - 18

HYDRAULIC COMPONENTS, FLOW CONTROL (627XT)..... Pages 19 – 21

POWER IN-FEED OPTIONPage 22

HYDRAULIC COMPONENTS, FLOW CONTROL & SPEED SENSINGPages 23 - 25

TORQUE CHARTSPage 26

WARRANTY POLICY/PROCEDUREPage 27

COPY OF WARRANTY CLAIM FORM.....Page 28

SERVICE SCHEDULE LOGPage 29

SALSCO, INC.
105 School House Rd., Cheshire, CT 06410
800-872-5726, 203-271-1682, 203-271-2596(Fax)
sales@salsco.com, www.salsco.com

STATEMENT OF FACT

You have just purchased the highest quality, most dependable, Wood Chipper on the market today. This unit has the ability to meet exact standards and perform for years with minimum downtime. **HOWEVER**, it cannot read nor will it understand this manual no matter how long you leave it on top of the machine.

IT IS YOUR RESPONSIBILITY to read and understand this manual; it is also your responsibility to be certain this information is passed along to anyone who is expected to operate this equipment. Should you choose not to read, understand and pass along the information provided you, please expect equipment failure and possible injuries to persons around this equipment.

For the safety of the operator, it is **IMPERATIVE** that this manual is carefully read and understood.

Once you have read this manual, it is your responsibility to be sure that all new operators read and understand this manual, especially all cautions stated.

As a manufacturer of equipment, we have a responsibility to design a safe piece of equipment. **NOTE:** The important safeguards and instructions in this manual are not meant to cover all possible conditions and situations that may occur. It must be understood that common sense, caution, and care are factors, which cannot be built into any product. These factors must be supplied by the person(s) caring for and operating this equipment.

ONLY YOU CAN PREVENT ACCIDENTS!!

SPECIFICATIONS AND FEATURES, MODEL 627XT CHIPPERS

The Model 627XT is also a 6" round wood capacity chipper, with the dual hydraulic feed option. We have installed clear, debris curtain strips to protect the user from fly back of material.

These units utilize ½" thick x 4" long, x 4" wide, double edge, chip blades and a ½" thick reversible, sharpenable, and replaceable bed knife, for consistent chip size and chipping capabilities of even those small, viney, stringy, and messy jobs! Bed knife adjustment or maintenance is easily done, as the bed knife is easily accessed on the face of the impeller housing where the left side of the infeed hopper meets the impeller housing. Chip blades are also easily accessed by simply unbolting the hinged impeller-housing door.

A 360 degree exhaust chute, provides the customer with the option of discharging material in any direction, without the necessity of tools.

With proper maintenance, these units will provide the user with many years of service. Like all Salsco products, they are built tough and durable. The powder coat baked enamel finish, will keep the unit looking new for many years.

You will notice throughout this manual, safety of operation is mentioned many times. Please follow these safety guidelines, as they are meant to provide you with the information you need to operate this equipment safely.

MACHINE REGISTRATION

MANUFACTURED BY:

SALSCO, INC.
105 School House Rd., Cheshire, CT 06410
800-872-5726, 203-271-1682, 203-271-2596 (Fax)
sales@salsco.com www.salsco.com

THIS MANUAL COVERS MODEL (s): 627XT CHIPPER

This company reserves the right to discontinue, add improvements to, or change the design of any model or product at any time without obligation to improve existing machines, either by changing the design or adding new parts.

It has been and will continue to be the policy of SALSCO to update existing machines at its own discretion. Whenever possible, new designs will be made in such a way that they can be "Retro Fit" if so desired.

Record in the space provided below the model and serial number of this unit. Please retain these numbers for future reference.

No parts orders will be accepted **WITHOUT MODEL NUMBERS OR PART NUMBERS**. All part numbers are listed in this manual.

Serial Number

Model Number

NOTE: Be sure to complete your warranty card. This will insure immediate processing of any warranty claims.

READ AND UNDERSTAND THIS MANUAL BEFORE STARTING MACHINE

BRUSH CHIPPERS ANSI Z133.1-2006

American National Standard for Arboricultural Operations Safety Requirements

5.3 Brush Chippers

- 5.3.1 The items contained in section 5.1 shall always be included in the review of this section.
- 5.3.2 Access panels (for example, guards) for maintenance and adjustment, including discharge chute and cutter housing, shall be closed and secured prior to starting the engine of brush chippers. These access panels shall not be opened or unsecured until the engine and all moving parts have come to a complete stop (see Annex C, General Safety Procedures That Apply to All Tree Work).
- 5.3.3 Rotary drum or disc brush chippers not equipped with a mechanical infeed system shall be equipped with an infeed hopper not less than 85 inches (2.15 m) measured from the blades or knives to ground level over the center line of the hopper. Side members of the infeed hopper shall have sufficient height so as to prevent workers from contacting the blades or knives during operations.
- 5.3.4 Rotary drum or disc brush chippers not equipped with a mechanical infeed system shall have a flexible anti-kickback device installed in the infeed hopper to reduce the risk of injury from flying chips and debris.
- 5.3.5 Chippers equipped with a mechanical infeed system shall have a quick-stop and reversing device on the infeed system. The activating mechanism for the quick-stop and reversing device shall be located across the top, along each side, and close to the feed end of the infeed hopper within easy reach of the worker.
- 5.3.6 Vision, hearing, and/or other appropriate personal protective equipment shall be worn when in the immediate area of a brush chipper in accordance with section 3.4, Personal Protective Equipment.
- 5.3.7 Arborists, mechanics, and other workers shall not, under any circumstances, reach into the infeed hopper when the cutter disc, rotary drum, or feed rollers are moving.
- 5.3.8 When trailer chippers are detached from the vehicles, they shall be chocked or otherwise secured in place.
- 5.3.9 When in a towing position, chipper safety chains shall be crossed under the tongue of the chipper and properly affixed to the towing vehicle.
- 5.3.10 See section 8.6, Brush Removal and Chipping, for additional requirements.

BRUSH REMOVAL AND CHIPPING ANSI Z133.1-2006

American National Standard for Arboricultural Operations Safety Requirements

8.6 Brush Removal and Chipping

- 8.6.1 Traffic control around the jobsite shall be established prior to the start of chipping operations along roads and highways (see section 3.2, Traffic Control Around the Jobsite).
- 8.6.2 Brush and logs shall not be allowed to create hazards in the work areas.
- 8.6.3 To prevent an entanglement hazard, loose clothing, climbing equipment, body belts, harnesses, lanyards, or gauntlet-type gloves (for example, long-cuffed lineman's or welder's gloves) shall not be worn while operating chippers.
- 8.6.4 Personal protective equipment shall be worn when in the immediate area of chipping operations in accordance with section 3.4, Personal Protective Equipment, of this standard.
- 8.6.5 Training shall be provided in the proper operation, feeding, starting, and shutdown procedures for the chipper being used.
- 8.6.6 Maintenance shall be performed only by those persons authorized by the employer and trained to perform such operations.
- 8.6.7 Brush and logs shall be fed into chippers, butt or cut end first, from the side of the feed table center line, and the operator shall immediately turn away from the feed table when the brush is taken into the rotor or feed rollers. Chippers should be fed from the curb-side whenever practical.
- 8.6.8 The brush chipper discharge chute or cutter housing cover shall not be raised or removed while any part of the chipper is turning or moving. Chippers shall not be used unless a discharge chute of sufficient length or design is provided that prevents personal contact with the blades (see Annex C, General Safety Procedures That Apply to All Tree Work).
- 8.6.9 Foreign material, such as stones, nails, sweepings, and rakings, shall not be fed into chippers.
- 8.6.10 Small branches shall be fed into chippers with longer branches or by being pushed with a long stick.
- 8.6.11 Hands or other parts of the body shall not be placed into the infeed hopper. Leaning into or pushing material into infeed hoppers with feet is prohibited.
- 8.6.12 While material is being fed into the chipper infeed hopper chute, pinch points continually develop within the material being chipped and between the material and machine. The operator shall be aware of this situation and respond accordingly.
- 8.6.13 When feeding a chipper during roadside operations, the operator shall do so in a manner that prevents him or her from stepping into traffic or being pushed into traffic by the material that is being fed into the chipper.
- 8.6.14 When using a winch in chipper operations, the operator shall ensure that the winch cable is properly stored before initiating chipper operations.
- 8.6.15 Refer to section 5.3, Brush Chippers, for additional information.

CAUTIONS

READ THOROUGHLY THE OPERATOR SAFETY INSTRUCTIONS ON THE PRECEEDING PAGES, WHICH ARE THE AMERICAN NATIONAL STANDARD OF POWERED SHREDDERS/GRINDERS, SAFETY SPECIFICATIONS PROVIDED BY ANSI AND THE O.P.E.I.

THE FOLLOWING CAUTIONS ARE PROVIDED BY SALSCO AS A QUICK REFERENCE ONLY AND ARE NOT MEANT TO REPLACE THE PRECAUTIONS ON THE FOLLOWING PAGES.

1. **ALWAYS** use protective eyewear when machine is in operation.
2. **ALWAYS** use gloves and wear ear protection when machine is in operation.
3. **NEVER** put hands, legs or any part of your body into or near Chipper intake or discharge openings.
4. **NEVER** run machine with guards or shaft cover removed.
5. **ALWAYS** allow machine to cool off, **BE SURE** machine has stopped completely, and disconnect drive shaft from tractor before attempting any maintenance, or repair.
6. **NEVER** stand in front of chipper infeed hopper. It is possible for a chip or piece of wood to be thrown out.
7. **BE SURE** the machine and tractor is parked on a dry level surface before starting operation.
8. **DO NOT** operate with loose clothing or long unrestrained hair. Be sure vines and branches are not wrapped around your body parts.
9. **DO NOT** operate on ice or any other slippery surface. Be sure area around machine is clear and clean. You do not want to trip into the machine.
10. **NEVER** leave machine running unattended, especially around youngsters or persons not instructed in the safe operation of this machine.
11. **READ** and understand federal guidelines provided with this manual.

NEVER run machine without connecting the 3-point to the tractor!

HOW TO CUT A DRIVE SHAFT

- 1) Attach the implement to the tractor. Raise and lower it. BE SURE its angle is correct and there is nothing hitting.
- 2) Raise and lower the chipper until the stub PTO shaft on the tractor and the implement are as close to each other as they can be.
- 3) Take a measurement **TIP TO TIP** on the stub shafts. **EXAMPLE:** Let's say 28" tip to tip is the measurement you made.
 - A. Slide the drive shaft apart and lay both halves on the bench so yokes are away from each other.
 - B. Set the halves so they are 28" apart. This dimension is from the inside yoke to inside yoke.
 - C. Now cut the excess from each half so when you slide the halves together you have 28" tip to tip.

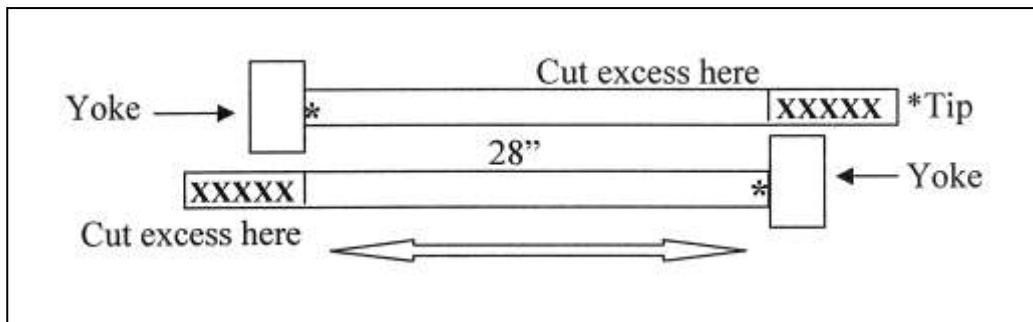

NOTES:

- **DON'T FORGET,** the yoke must fit over the stub shaft.
- You can cut it again **EASIER** than you can add.

**SAFETY FIRST – ALWAYS WEAR PROTECTIVE GEAR WHEN
WORKING WITH/ON EQUIPMENT/TOOLS!**

**627 PTO/627XT
SERVICE SCHEDULE**

1. Whenever service is to be done to a PTO implement, be sure to disconnect the drive shaft.
2. **GREASE** all bearings daily. **DO NOT OVER GREASE.** Wipe extra grease off bearings.
3. **To sharpen blades:** Remove hopper or open door (depending on which model machine). Remove blades and replace with sharpened ones. It is recommended that you replace the hardware whenever replacing blades. Be sure to follow the torque specifications in your manual. Be sure to clean mounting surface before bolting new blades. Be sure to use Locktite when replacing hardware.
4. **Bed knife adjustment:** This adjustment varies from 1/16" to 1/4". The larger the opening, between bed knife and chip blades, the faster the wood will feed and the harder the machine will have to work. The smaller the opening, the slower it will feed and the less work the machine will have to do. We recommend 1/8" to 3/16".
5. Be sure you double-check all nuts and bolts for tightness. A loose bolt can cause total destruction of the machine.
6. Keep machine clean and free from dirt.

SERVICE SCHEDULE	AS NEEDED	DAILY	WEEKLY
CLEAN MACHINE	X	X	
GREASE DISC SHAFT BEARING	X	X	
SHARPEN CHIPPER BLADES	X OR		X
CHECK & ADJUST BED KNIFE	X	X	
CHECK ALL NUTS & BOLTS			X

NEVER, UNDER ANY CIRCUMSTANCES, START THE ENGINE WHEN UNIT IS OPEN OR AT ANY TIME DURING SERVICE OR ROUTINE MAINTENANCE.

OPERATING INSTRUCTIONS – MODEL 627XT CHIPPER

- 1) After cutting PTO Shaft, following the instructions on Page 9 of this manual, hook up to the tractor. **NEVER** RUN MACHINE WITH GUARDS OR SHAFT COVER REMOVED.
- 2) Secure 3 – Points to tractor. **NEVER** RUN MACHINE WITHOUT CONNECTING THE 3-POINT TO THE TRACTOR.
- 3) Hook up the hydraulic lines to the tractor, making sure they are locked in correctly. Unit requires approximately 6 G.P.M. or more, from the tractor.
- 4) Hook wiring up on Optional Speed Sensing (If purchased with unit). Follow calibration directions on pages 19 – 21 of this manual.

REVIEW SAFETY INSTRUCTIONS AND CAUTIONS IN THIS MANUAL BEFORE YOU PROCEED.

- 5) Start tractor, engage auxiliary hydraulics, and engage PTO. Bring tractor RPM up, until PTO output RPM reaches 540RPM.
- 6) Adjust flow control valve if there's more oil than needed. Move adjustment handle towards 10 to slow down the infeed rate. This will dump the oil back to tank and slow down the infeed to a comfortable infeed speed.
- 7) Forward and reverse is controlled by operating the handle bar over the infeed hopper.
- 8) Remove pin at infeed housing, behind feed rolls, to pivot open the infeed housing, if it becomes necessary to remove debris. **ALWAYS** ALLOW MACHINE TO COOL OFF & **BE SURE** MACHINE HAS STOPPED COMPLETELY, & **DISCONNECT** DRIVE SHAFT FROM THE TRACTOR BEFORE ATTEMPTING ANY MAINTENANCE, OR REPIAR.

NEVER LEAVE MACHINE RUNNING UNATTENDED!

ITEM	DESCRIPTION	PART NO	QTY
	627XT PTO CHIPPER - DWG #1	0010127	

ISSUED: 06-25-2008

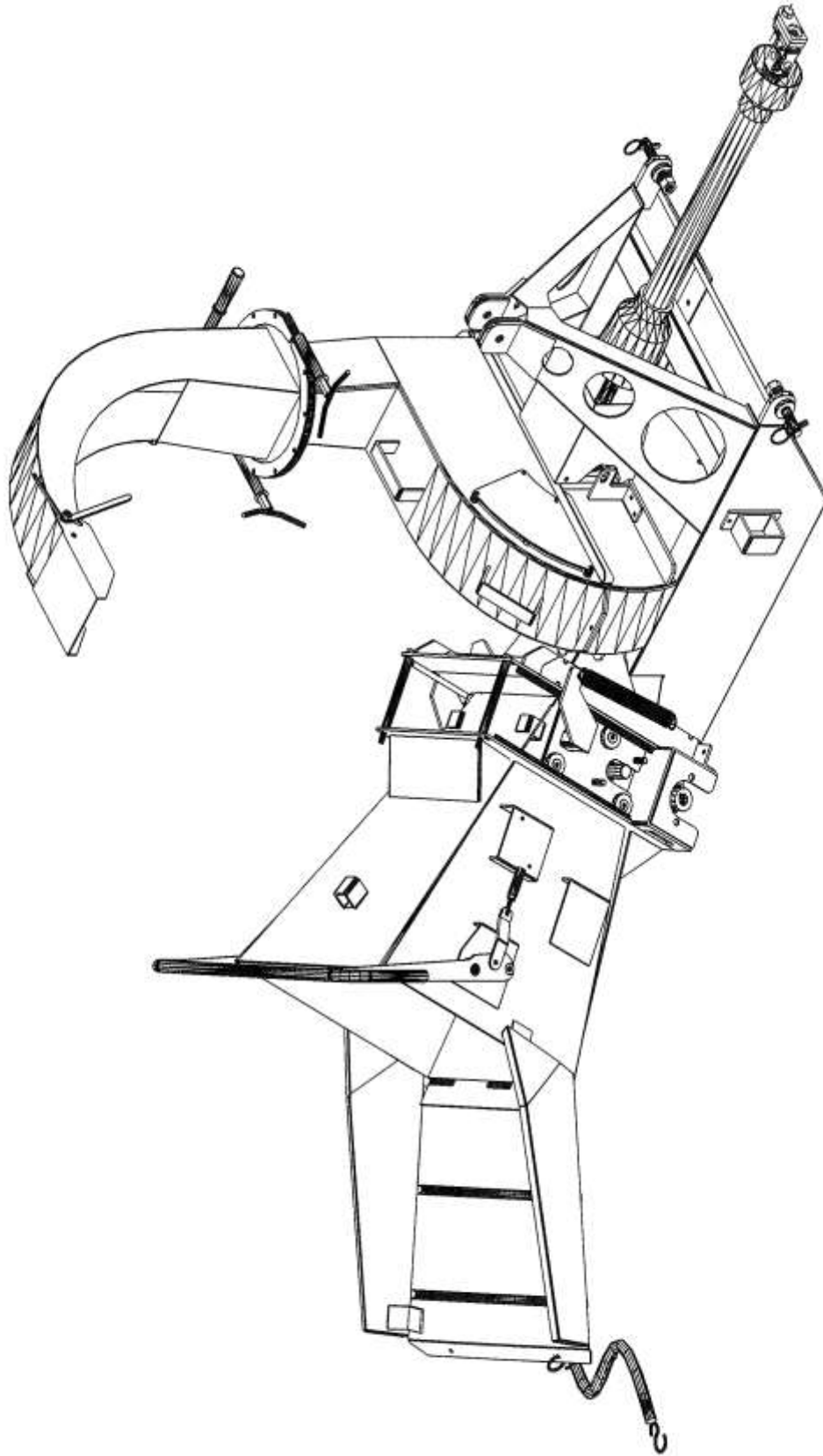

627XT PTO CHIPPER - DWG #1

REV	DESCRIPTION	DATE

ISSUED: 06-01-2010

ITEM	DESCRIPTION	PART NO	QTY
1	HOUSING, IMPELLER - UPPER	0228247	1
2	PIN, IMPELLER HOUSHING HINGE	0240117	1
3	BRACKET, IMPEL. SHAFT GUARD MOUNT	0406779	1
4	GUARD, IMPELLER SHAFT	0421428	1
5	HOLDER, MANUAL TUBE	0481029	1
6	BRACKET, MAGNETIC PICK-UP MOUNT'G	0406878	1
7	GUARD, IMPELLER SHAFT	0421466	1
8	NUT, NYLOCK	0338043	1
9	SHEAR BOLT	0346887	1
10	DRIVE SHAFT, COMPLETE WITH SHIELD	0348242	1
11	SPRING, EXTENSION	0350018	2
12	PIN, IN-FEED CHUTE HING	0240144	1

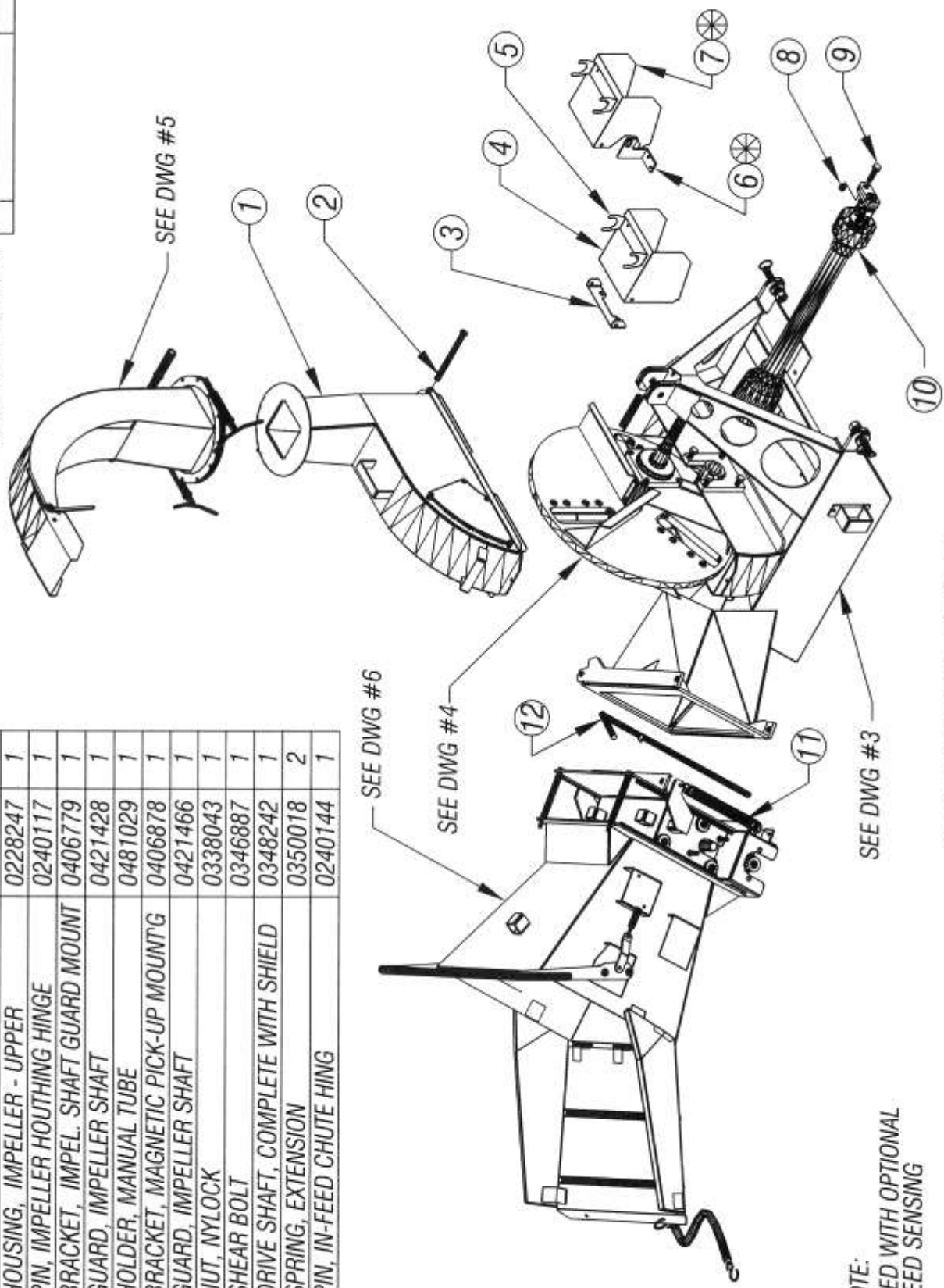

NOTE:
USED WITH OPTIONAL
SPEED SENSING

627XT PTO CHIPPER - DWG #2

ISSUED: 06-25-2008

ITEM	DESCRIPTION	PART NO	QTY
1	HOUSING, IMPELLER - LOWER w/ BULKHEAD	0228257	1
2	LYNCH PIN	0340102	2
3	DRAW PIN	0340106	2
4	BLADE, BED KNIFE	0405128	1
5	BOLT, HEX HEAD	0346535	3
6	LOCK WASHER	0353014	3
7	FLAT WASHER	0353110	3
8	BEARING, 4-BOLT, FLANGED	0303059	2
9	BRACKET, HYD HOSES SECURING	0206911	1

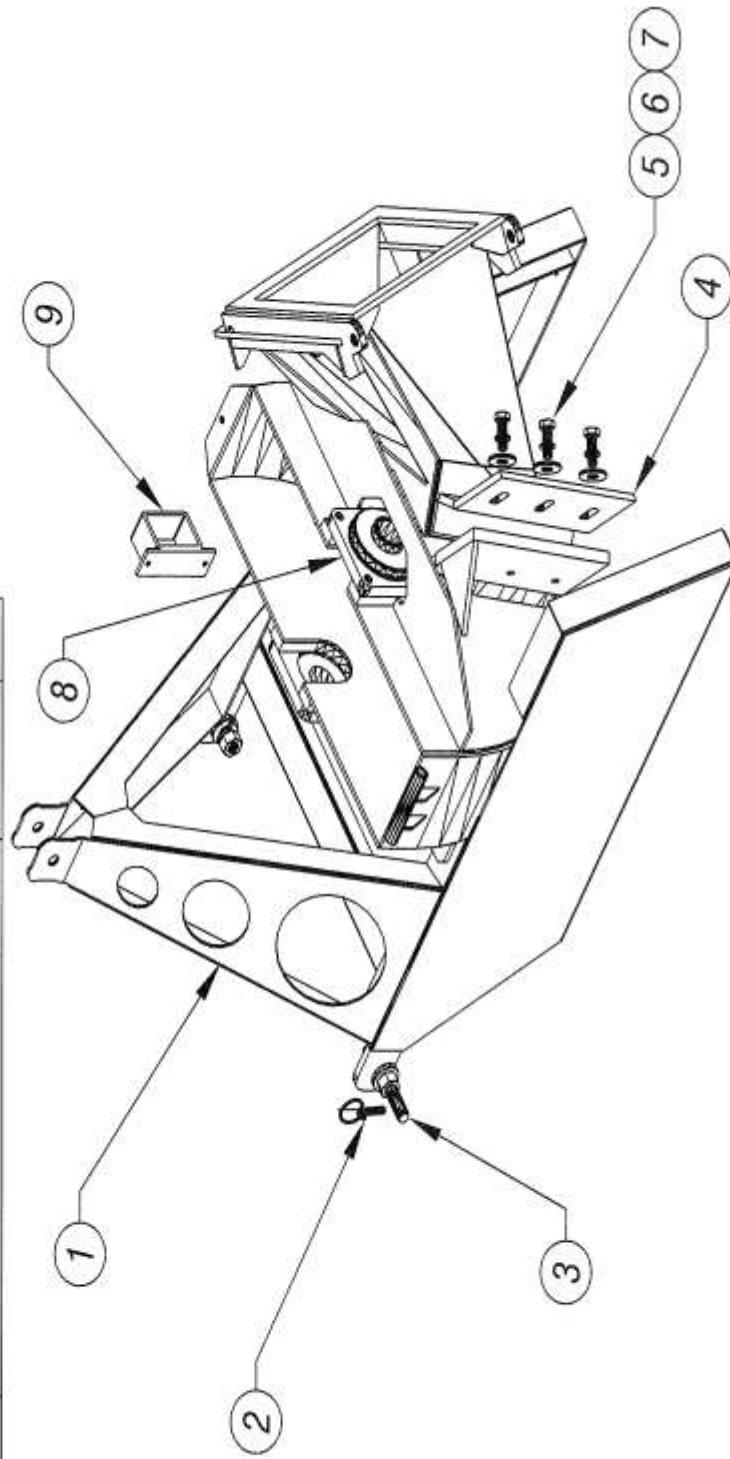

627XT PTO CHIPPER - DWG #3

ISSUED: 06-25-2008

ITEM	DESCRIPTION	PART NO	QTY
1	SHAFT / IMPELLER	0248224	1
2	BLADE, CHIPPER, DOUBLE EDGE	0305090	6
3	FLAT HEAD SOC CAP SCREW	0346487	12
4	LOCK WASHER	0353017	12
5	NUT, STOVER	0338154	12

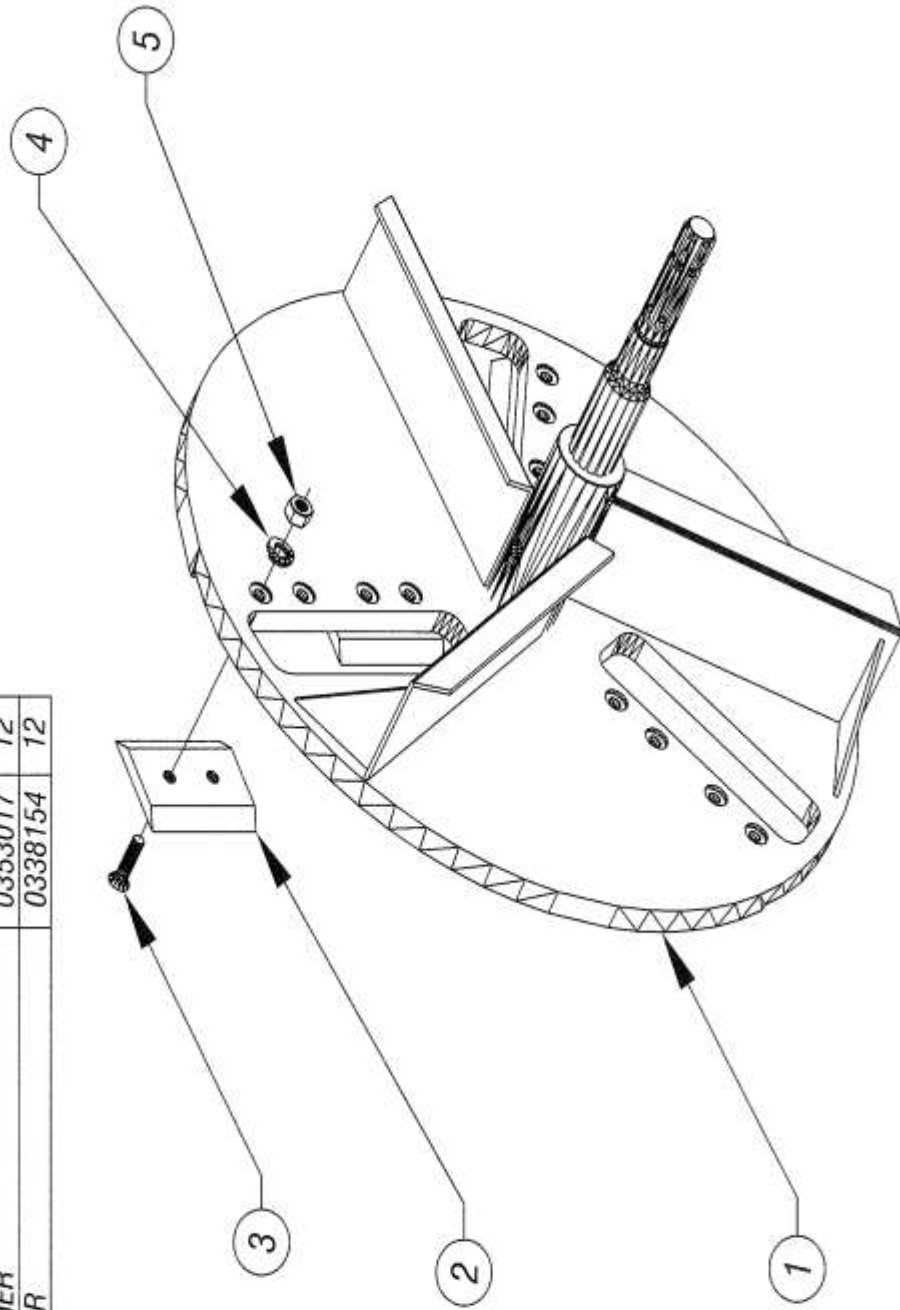

627XT PTO CHIPPER - DWG #4

ISSUED: 06-25-2008

ITEM	DESCRIPTION	PART NO	QTY
1	CHUTE, EXHAUST	0226147	1
2	CLAMP, EXHAUST CHUTE - FRONT	0210147	1
3	RUBBER GRIP	0332009	2
4	WING NUT, EXHAUST CLAMP	0238504	2
5	CLAMP, EXHAUST CHUTE - REAR	0210148	1
6	WING NUT, CHUTE DEFLECTOR	0238500	1
7	CHUTE DEFLECTOR	0439799	1

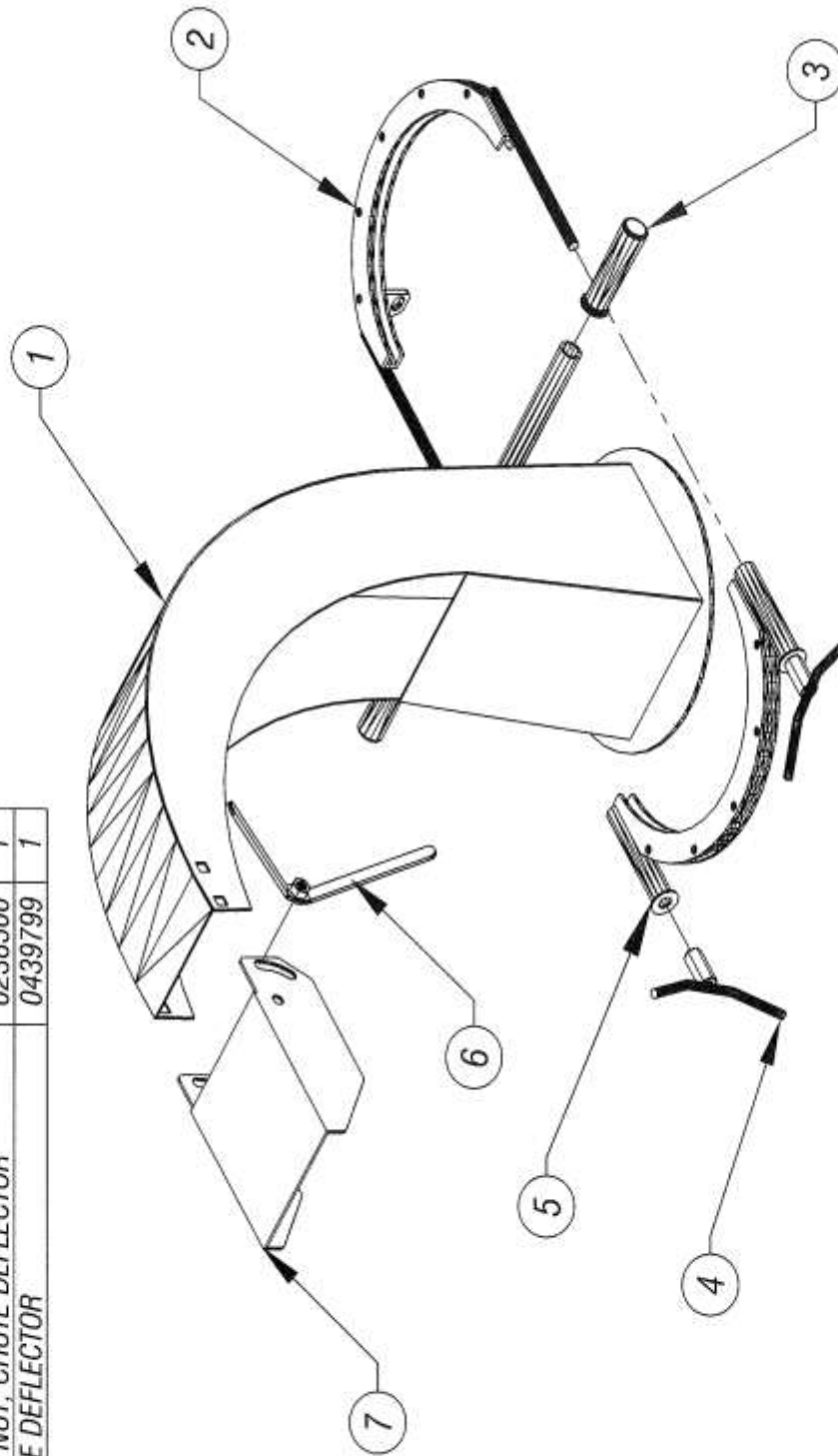

627XT PTO CHIPPER - DWG #5

REV	DESCRIPTION	REVISION	DATE

ISSUED: 06-01-2010

ITEM	DESCRIPTION	PART NO	QTY
1	HANDLE, FWD / REV POWER IN-FEED	0223133	1
2	CHUTE, POWER IN-FEED	0226163	1
3	STUD, IN-FEED CHUTE SUPPORT	0279006	2
4	FLAT WASHER, - 1/2 I.D.	0353115	2
5	TUBE, DOM-3/4 OD x 1/8 WALL x 6 3/4 LG	STOCK	2
6	LOCK WASHER, SPLIT - 1/2 I.D.	0353005	2
7	HEX NUT, - 1/2-13	0338005	2
8	VALVE, DIRECTIONAL, HYDRAULIC	0330132	1
9	ADJUSTER, FIR VALVE	0201038	1
10	LEVER, FORWARD/REVERSE VALVE	0233207	1
11	DOOR, FOLDING IN-FEED CHUTE	0260071	1
12	BUNGIE CORD - 10"	0308013	1

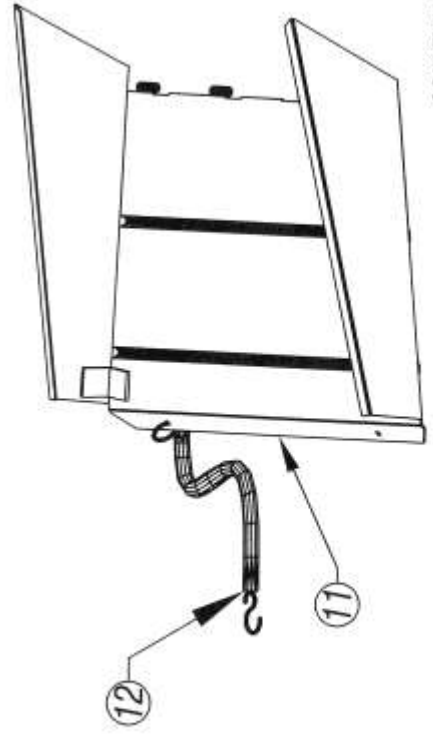
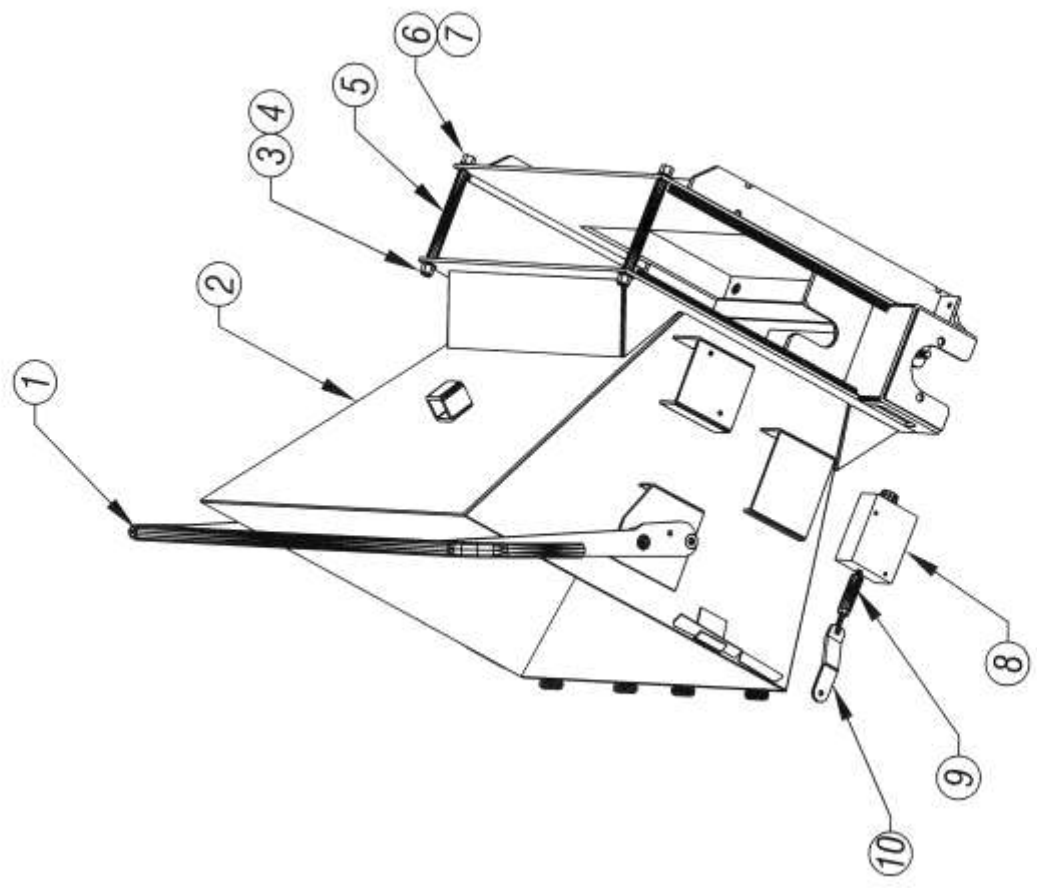

627XT PTO CHIPPER - DWG #6

ISSUED: 06-25-2008

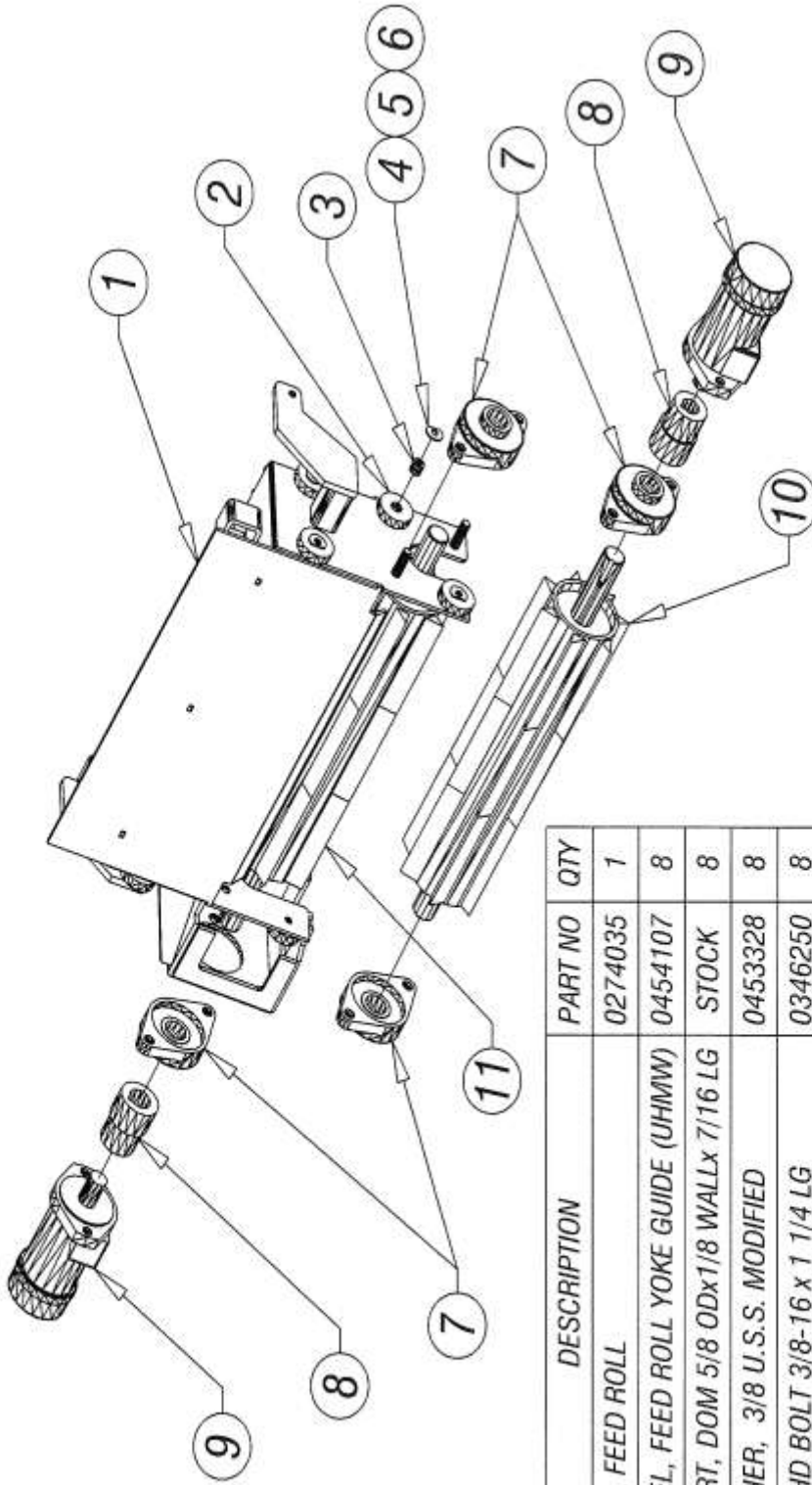

ITEM	DESCRIPTION	PART NO	QTY
1	YOKE, FEED ROLL	0274035	1
2	WHEEL, FEED ROLL YOKE GUIDE (UHMW)	0454107	8
3	INSERT, DOM 5/8 ODx1/8 WALLx 7/16 LG	STOCK	8
4	WASHER, 3/8 U.S.S. MODIFIED	0453328	8
5	HEX HD BOLT 3/8-16 x 1 1/4 LG	0346250	8
6	LOCK NUT, 3/8-16	0338102	8
7	BEARING, 2-BOLT FLANGED, 1 1/4 BORE	0303031	4
8	COUPLING, POWER FEED ROLLER	0213062	2
9	DRIVE MOTOR, HYDRAULIC	0330143	2
10	WHEEL, FEED ROLL - LOWER	0254106	1
11	WHEEL, FEED ROLL - UPPER	0254105	1

627XT PTO CHIPPER - DWG #7

ISSUED: 06-25-2008

HYDRAULIC COMPONENTS

ITEM	DESCRIPTION	PART NO	QTY
1	VALVE, ADJUST. FLOW CONTROL	0330083	1
2	DRIVE MOTOR, HYDRAULIC	0330143	2
3	VALVE, DIRECTIONAL	0330132	1

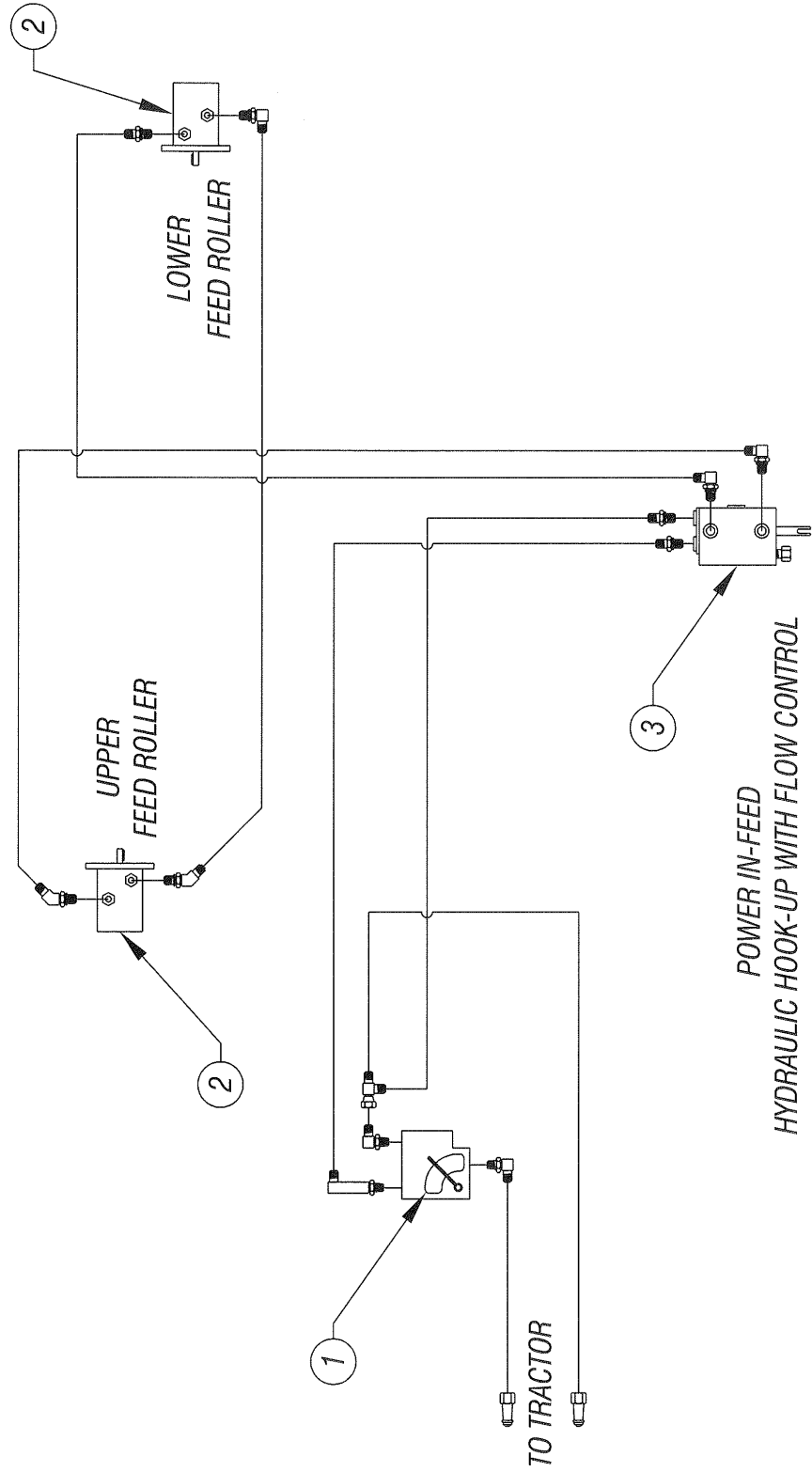

ISSUED: 06-25-2008

HYDRAULIC FITTINGS

ITEM	DESCRIPTION	PART NO	QTY
1	45° ELBOW, 1/2 FLARE x 5/8 O-RING	0317247	2
2	CONNECTOR, 1/2 FLARE x 5/8 O-RING	0317027	1
3	90° ELBOW, 1/2 FLARE x 5/8 O-RING	0317008	1
4	90° ELBOW, 1/2 FLARE x 3/8 O-RING	0317064	2
5	CONNECTOR, 1/2 FLARE x 1/2 O-RING	0317030	2
6	SWIVEL TEE RUN, 1/2 x 1/2 x 1/2	0317118	1
7	90° ELBOW, 1/2 FLARE x MALE NPT	0317052	2
8	90° ELBOW, LONG 1/2 FLARE x M NPT	0317108	1
9	QUICK DISCON. COUPLER, 1/2 FLARE	0317279	2

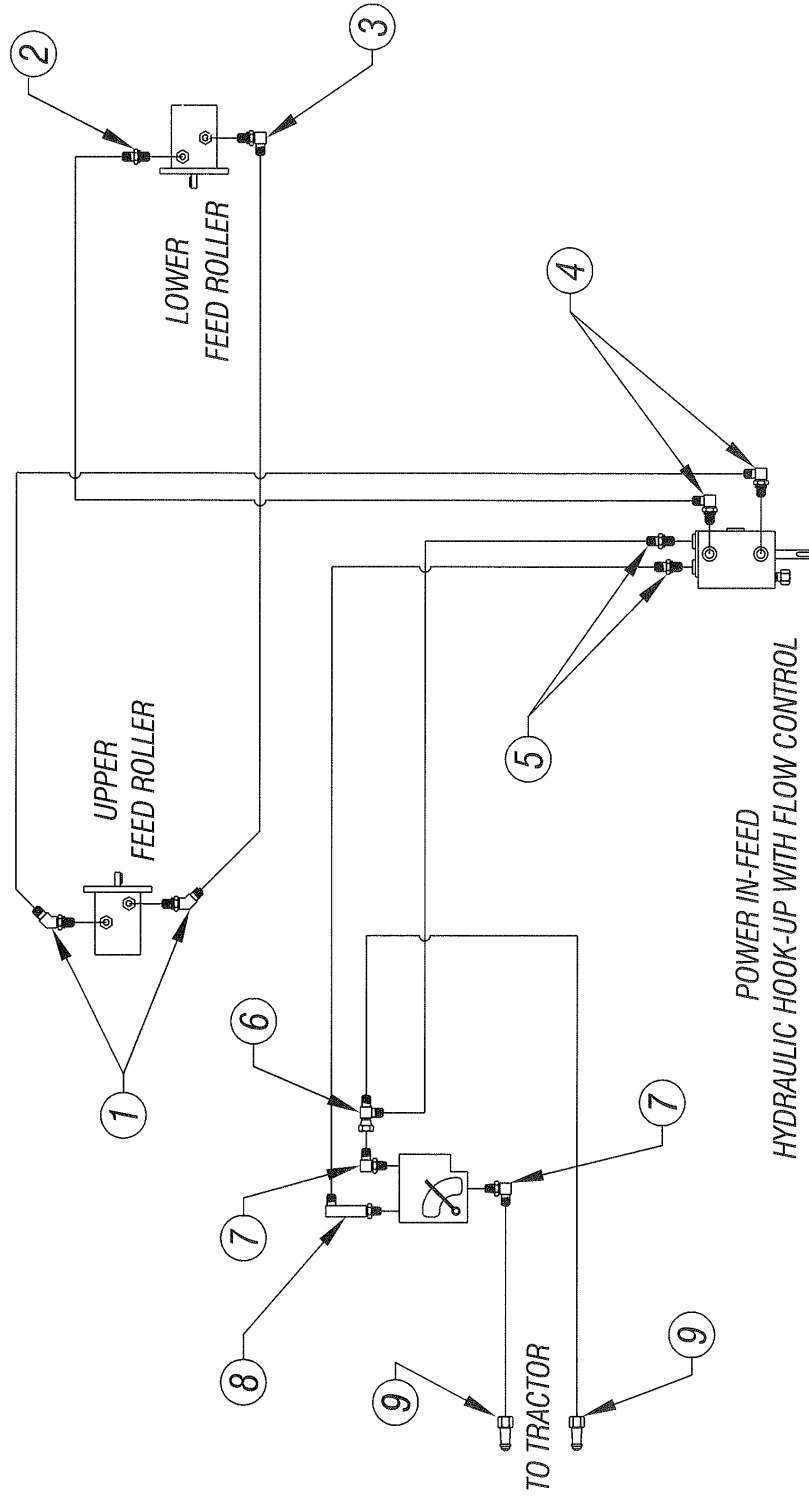

POWER IN-FEED
 HYDRAULIC HOOK-UP WITH FLOW CONTROL
 627XT PTO CHIPPER - DWG #9

ISSUED: 06-25-2008

HYDRAULIC HOSES

ITEM	DESCRIPTION	PART NO	QTY
1	VALVE TO L.PUMP, 1/2 ID x 18" 90°L	0327078	1
2	L.MOTOR TO U.MOTOR, 1/2 I x 58"	0327257	1
3	VAL TO U.MOTOR, 1/2 ID x 41" 45°	0327375	1
4	VAL TO TEE FL CONTRL 1/2 IDx21"90°	0327209	1
5	VAL TO FLW CTRL, 1/2 ID x 18" 90°L	0327078	1
6	FLOW CONTROL TO TRACTOR	0327378	2

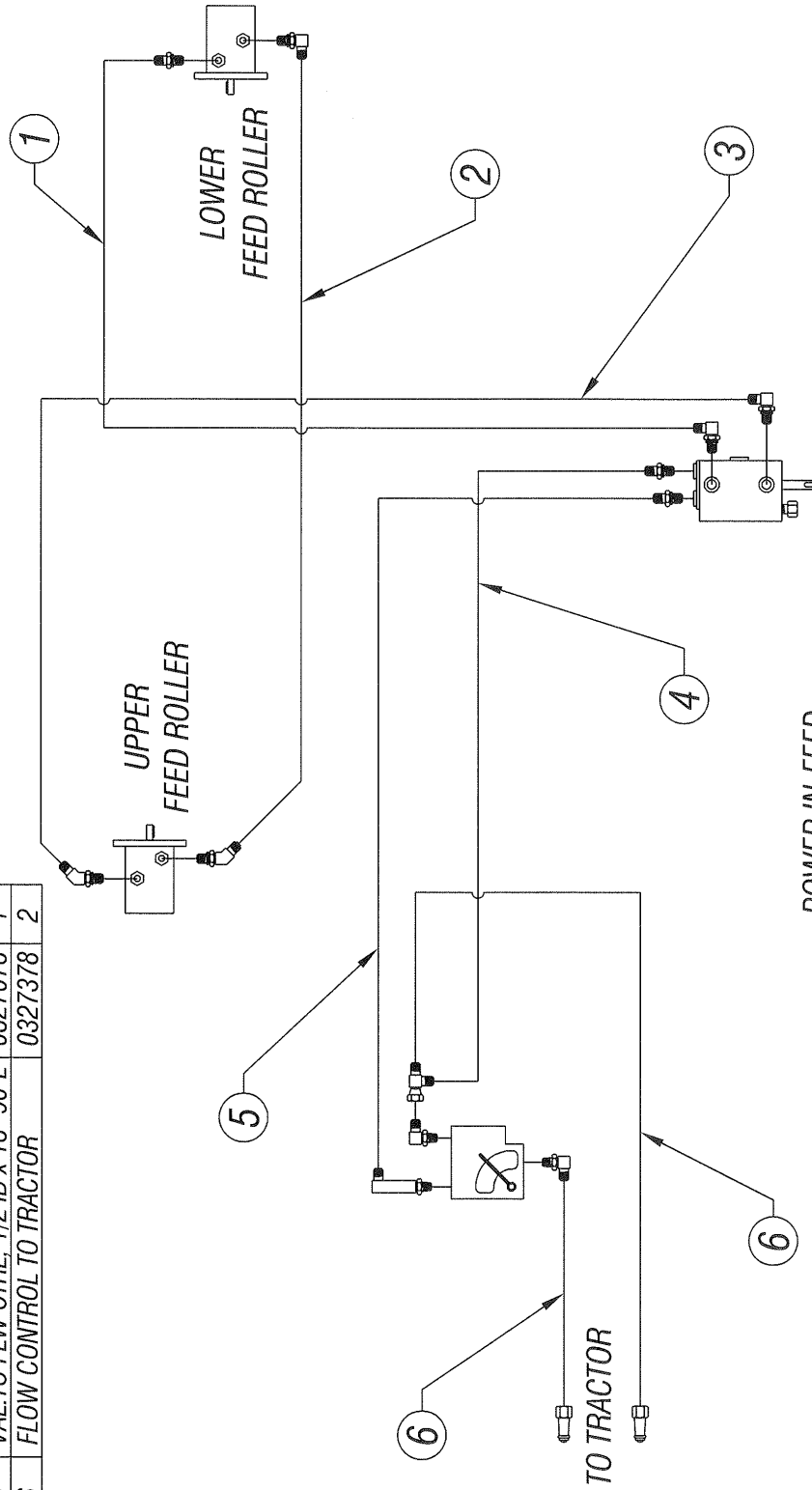

POWER IN-FEED
HYDRAULIC HOOK-UP WITH FLOW CONTROL
627XT PTO CHIPPER - DWG #10

ISSUED: 06-25-2008

ITEM	DESCRIPTION	PART NO	QTY
1	MOUNT, SPEED SENSING GAUGE BOX	0276458	1
2	TACHOMETER WITH WIRING HARNESS	0315250	1
3	GUARD, SPEED SENSING GAUGE	0421398	1
4	PLATE, SPEED SENSING BOX - FRONT	0262258	1
5	BRACKET, MAGNETIC PICK-UP MOUNT'G	0406878	1
6	MAGNETIC PICK-UP	0315128	1
7	COLLAR, SPEED SENSING	0411057	1
8	CARRAGE BOLT, 3/8-16 x 1" LONG	0346228	2
9	JAM NUT, 3/8-16	0338052	2
10	GUARD, IMPELLER SHAFT	0421466	1

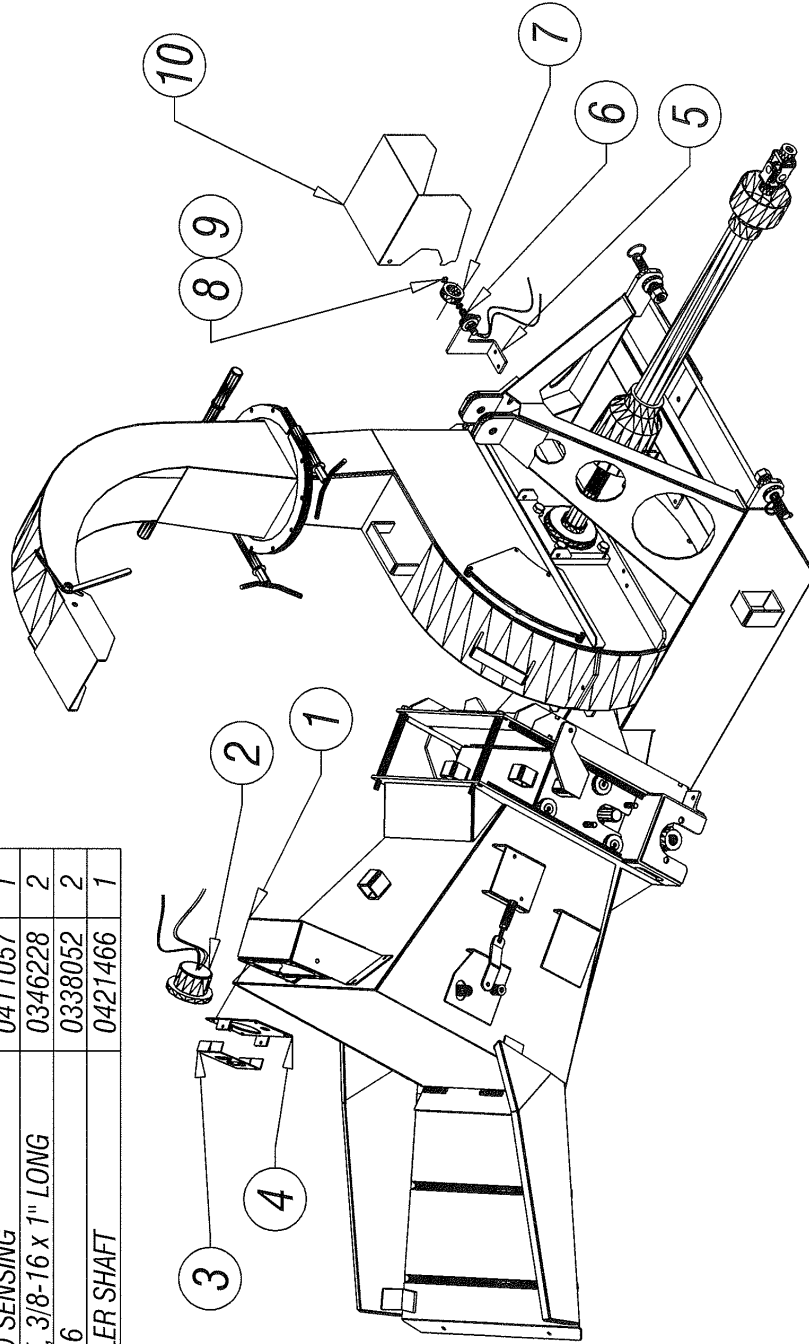

POWER IN-FEED OPTION #0161284
 SPEED SENSING ITEM
 627XT PTO CHIPPER - DWG #11

ISSUED: 06-25-2008

HYDRAULIC COMPONENTS

ITEM	DESCRIPTION	PART NO	QTY
1	VALVE, ADJ. FLOW CONTROL	0330083	1
2	DRIVE MOTOR, HYDRAULIC	0330143	2
3	SOLENOID VALVE	0330106	1
4	VALVE, HYD. DIRECTIONAL	0330132	1

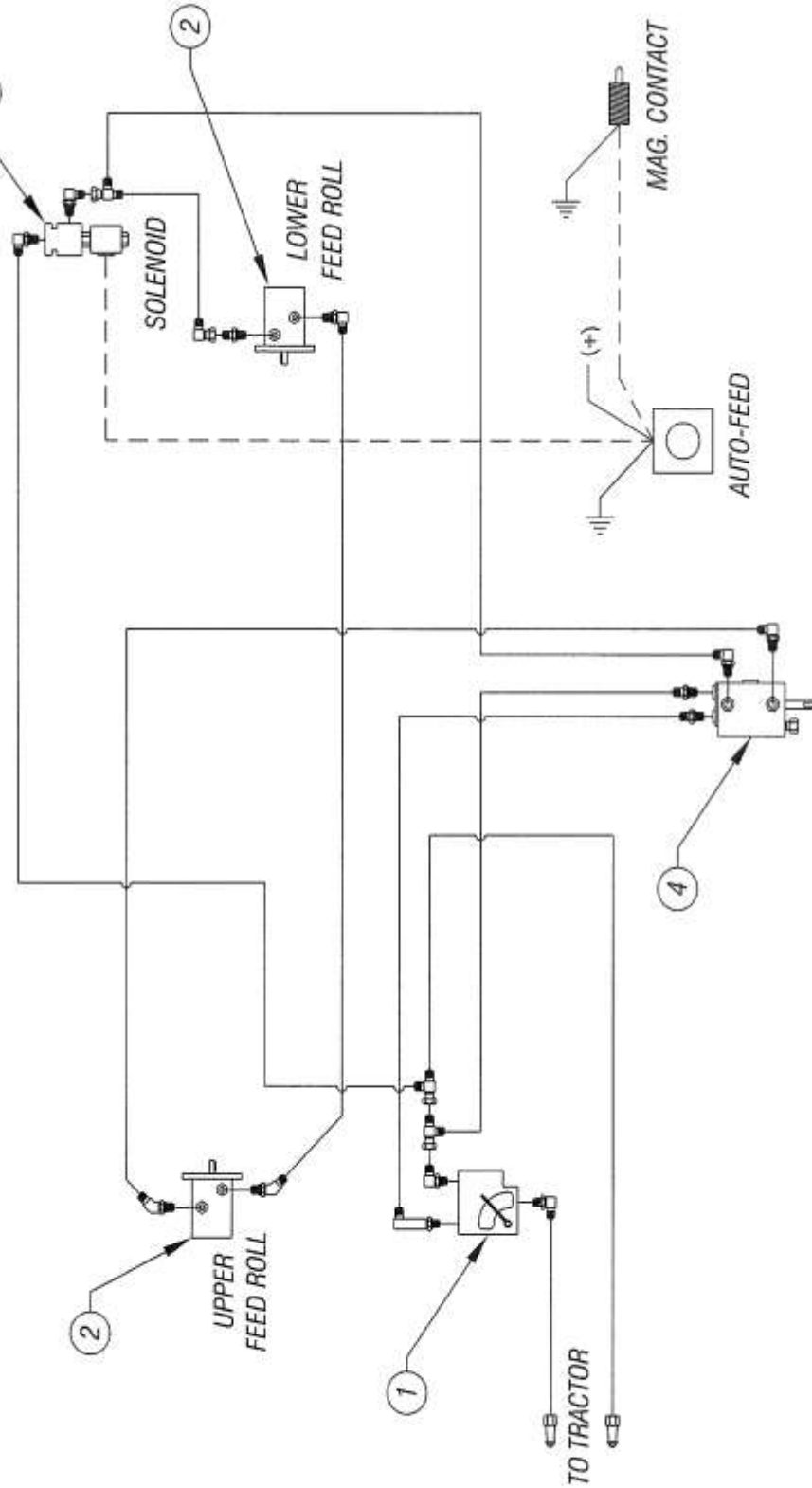

POWER IN-FEED OPTION #0161284
 HYDRAULIC HOOK-UP WITH FLOW CONTROL & SPEED SENSING
 627XT- PTO CHIPPER - DWG #12

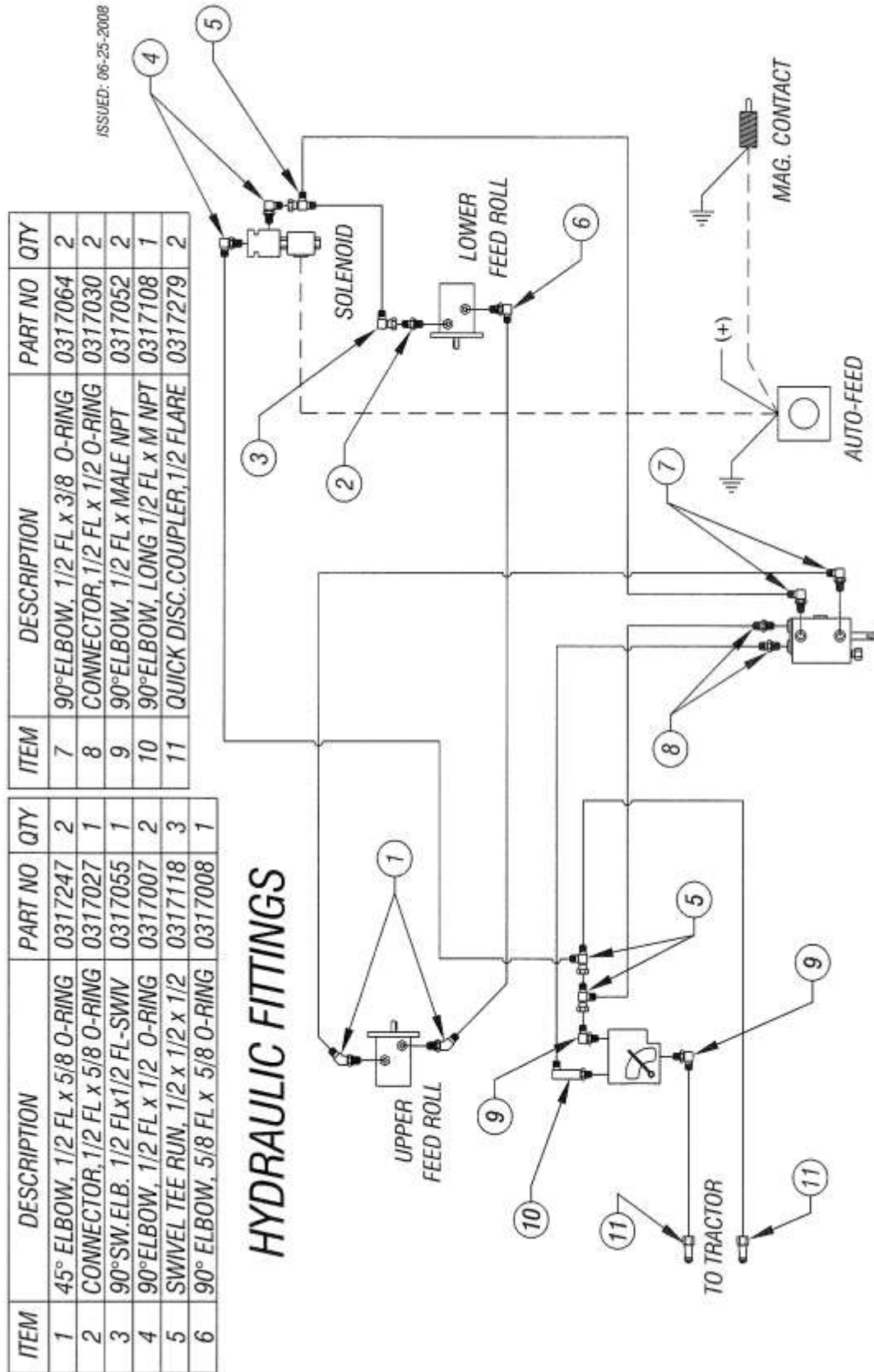

POWER IN-FEED OPTION #0161284
 HYDRAULIC HOOK-UP WITH FLOW CONTROL & SPEED SENSING
 627XT- PTO CHIPPER - DWG #13

ITEM	DESCRIPTION	PART NO	QTY	ITEM	DESCRIPTION	PART NO	QTY
1	VALVE TO "T" AT SOL. 1/2 ID x 29"	0327236	1	6	L.MOTOR TO U.MOTOR, 1/2 IDx58"	0327257	1
2	SOL. TO L.MOTOR, 1/2 ID x 20"	0327142	1	7	UPR.MOTOR TO VALVE, 1/2 IDx41"	0327375	1
3	AUTO-FEED TO VALVE, 1/2 ID x18"	0327078	1	8	SOL TO "T" AT A-FEED, 1/2 IDx18"	0327078	1
4	VALVE TO "T" AT SOL. 1/2 ID x 21"	0327209	1				
5	AUTO-FEED TO TRACTOR, 1/2 x96"	0327378	2				

ISSUED: 06-25-2008

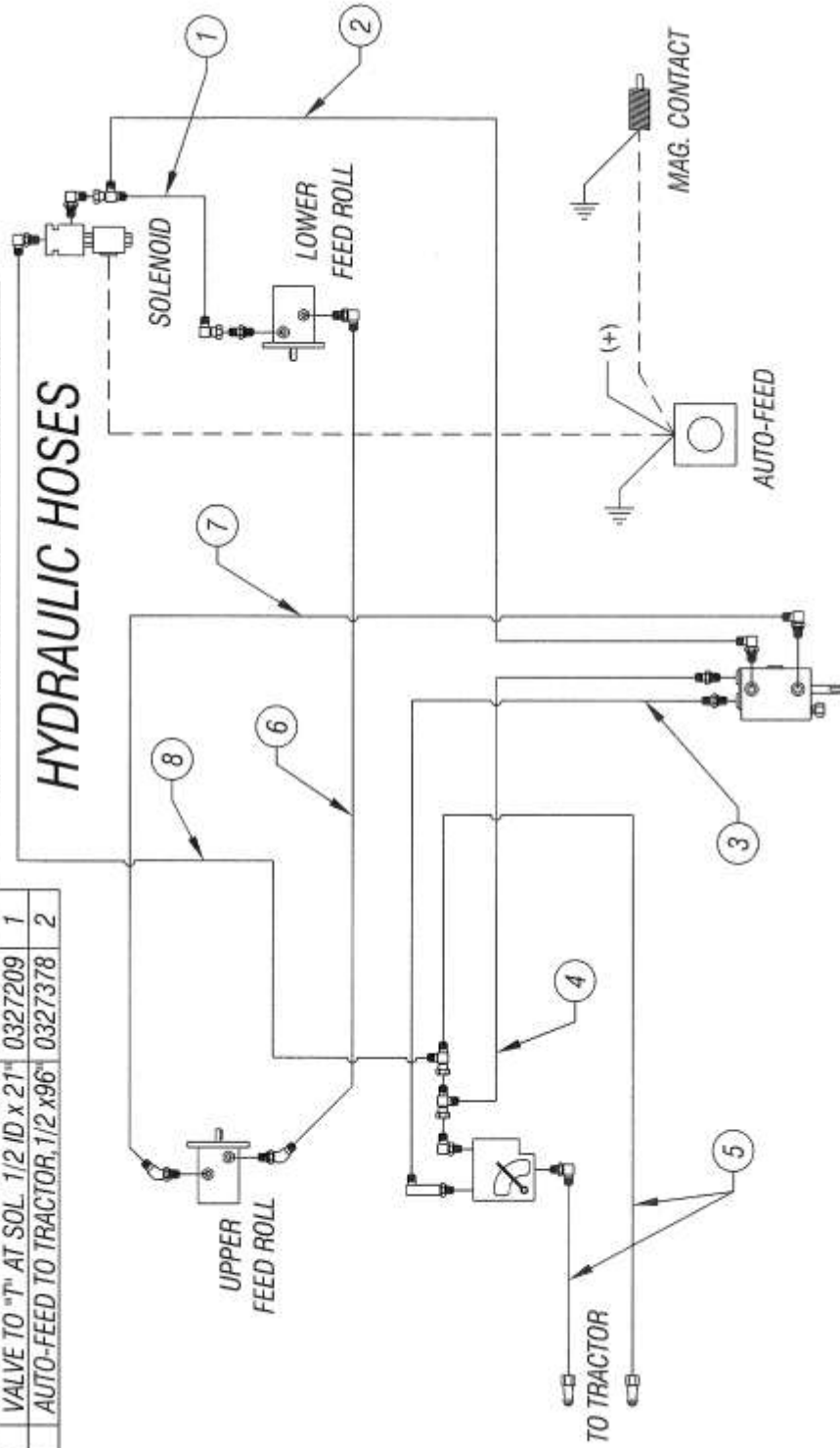

POWER IN-FEED OPTION #0161284
 HYDRAULIC HOOK-UP WITH FLOW CONTROL & SPEED SENSING
 627XT- PTO CHIPPER - DWG #14

TORQUE CHART

Size	Grade 5			Grade 8		
	Clamps (lbs)	Torque (ft-lbs)		Clamps (lbs)	Torque (ft-lbs)	
		dry	oiled		dry	oiled
1/4-20	2000	8	6	2850	12	9
1/4-28	2300	10	7.5	3250	14	10
5/16-18	2250	17	13	4700	25	18
5/16-24	3700	19	14	5200	25	20
3/8-16	4950	30	23	7000	45	35
3/8-24	5600	35	25	7900	50	35
7/16-14	6800	50	35	9550	70	55
7/16-20	7600	55	40	10650	80	60
1/2-13	9000	75	55	12750	110	80
1/2-20	10250	90	65	14375	120	90
9/16-12	11600	110	80	16375	150	110
9/16-18	13000	120	90	18250	170	130
5/8-11	14400	150	110	20350	220	170
5/8-18	16375	180	130	23000	240	180
3/4-10	21300	260	200	30100	380	280
3/4-16	23800	300	220	33500	420	320

Drive Belt Tension Measurement by Deflection

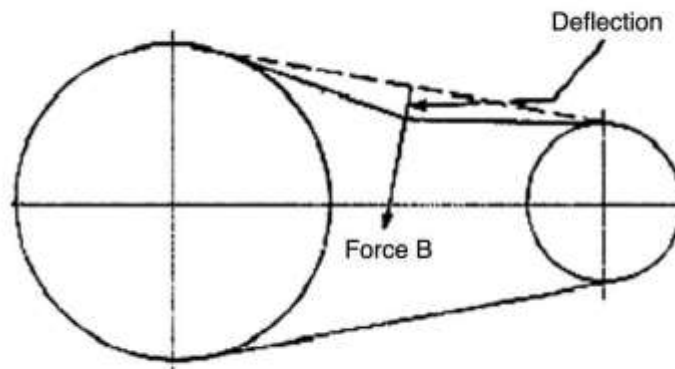

Deflection should be 3/8" when
8-12 lbs. push is applied at "B"

WARRANTY POLICY

Please remember to complete and return your Warranty Card and Dealer Delivery Report. Warranty Claims will not be considered if the Warranty Card and Dealer Delivery Report have not been returned to Salsco.

Your Salsco Commercial or Turf Equipment product is a commercial type product and is normally manufactured and sold for commercial or industrial use. **Salsco will, for the original purchaser, for one (1) year from the date of purchase (90 days if used for rental purposes) repair or replace, free of charge, any SALSCO part or parts found to be defective in material, workmanship or both.** Any transportation or shipping charges will be borne by the purchaser. If, during the warranty period stated above, the product does not function properly due to defect, simply contact Salsco and follow the Warranty Procedures included in this manual.

This warranty **does not** include:

- Incidental or consequential damages and is exclusive of any implied warranties.
- Normal maintenance parts, including, but not limited to hoses, chains, belts, filters, lubricants, etc.
- Parts or components, which are covered under the original manufacturer warranty, including, but not limited to engines, pumps, and motors.

WARRANTY PROCEDURE

In order for Salsco to consider your warranty claims in a timely manner you must follow the simple procedures listed below:

MACHINE OR PART FAILURE

- a) Call our service department for helpful instruction on how to correct or repair the problem. Preventive maintenance will also be suggested.
- b) When ordering parts for Warranty issues, you MUST retain possession of the old parts in question until notified with respect to returning the parts to Salsco or other disposition.
- c) Warranty Claims MUST be filed within 30-days from completion of the work performed. Contact our office for an electronic warranty claim form.
- d) Fill in all information requested on warranty claim form, a copy of which is included in this manual, (date of purchase, company name, address, etc.). List all parts used. Make sure part numbers are correct. You can obtain these from your manual. (include good description of problem; i.e. "leaking from spool" rather than "leaking").
- e) It is our goal to consider and reach a disposition on each Warranty Claim within 30-days from the date that it is received. Therefore it is important that you respond promptly to any request for further information. Claims with no response to inquiries will be closed as "**denied for lack of response**" 90-days from the date of request.
- f) Email, Fax or Send Warranty Claim form to our Warranty Department. – **Warranty on parts most often requires return of the parts that were replaced.** DO NOT DISCARD OLD PARTS UNTIL YOU HAVE RECEIVED A DETERMINATION AS TO WHETHER THESE PARTS MUST BE RETURNED.
- g) Our Warranty Department will contact and instruct you on how to return the Parts to Salsco on an RA #. Returns MUST be made within 30-Days from issuance of RA #. **FREIGHT CHARGES ON RETURN OF PARTS IS THE RESPONSIBILITY OF THE CUSTOMER.** Normal pre-delivery adjustments are not covered under warranty. Labor Warranties are based on reasonable time allowances as determined by Salsco, Inc. and paid at 75% of posted labor rate. **TRAVEL TIME IS NOT REIMBURSED UNDER THE WARRANTY POLICY.**
- h) Be sure to put the RA form inside the box that you are shipping back, also be sure to put on the outside of the box "Return of Goods" and the RA #.
- i) Ship returns via a traceable method such as UPS Ground Service. Be sure that the shipment is insured for the appropriate value. If uninsured parts are lost, we cannot issue a credit.

PLEASE NOTE: *Warranty forms should be filled out completely.*

PREVENTIVE MAINTENANCE IS YOUR BEST INSURANCE AGAINST EQUIPMENT FAILURE. BE SURE TO READ THIS MANUAL, ESPECIALLY THE MAINTENANCE, OPERATING AND CAUTION SECTIONS.

**SALSCO, INC., 105 School House Rd.
Cheshire, CT 06410
800-872-5726, 203-271-1682
203-271-2596 (Fax)
sales@salsco.com, www.salsco.com**

WARRANTY CLAIM FORM

SALSCO, INC.
105 School House Rd.
Cheshire, CT 06410

Phone: (203) 271-1682, (800) 872-5726
Fax: (203) 271-2596
Email: s.clark@salsco.com
Website: www.salsco.com

END OWNER

Date Submitted:

Name:	Phone:	Work Order #:
Email:	Fax:	Office Use Only
Address:		Date Rec'd
		Cust ID:
		Salsco WC
		Salsco RA

PURCHASED FROM

Name:	Phone:	Date Approved:
Email:	Fax:	Date Rejected:
Address:		Processed By:
		Dir. Del Report on File: YES NO
		Warranty Card on File: YES NO
		Part(s) Total:

Equipment/Warranty Information (Must be complete)

Purchase Date:	Invoice #	Date Failed:	Labor Total:
			Total Approved:
Model #:	Serial #:	Repair Date:	Approved/Rejected:
			Name:
Hrs Used:	Primary Use:		Reason for Rejection:
Warranty Claim/Work Order#:			
Was a Salsco Return Authorization # issued for repairs or			
Return of Parts?	YES	NO	Suggested Preventative Maint:
Probable Cause of Failure:			

Work Performed/Comments on Repair:

Shop Labor Rate:						Submitted By:	
Total Labor Hours to Repair:						Printed Name:	
Parts Required for repair							
Salsco Part #: Description:				Qty.	Price Each	Total	Inv #
						\$	
						\$	
						\$	
						\$	

Fill in all information requested on warranty claim form.
INCOMPLETE FORMS CANNOT BE PROCESSED & WILL BE RETURNED
List all parts used. Make sure part numbers are correct. Any parts that you believe to be defective or any parts that break should be retained for possible inspection until after the warranty has been paid or part has been replaced.

