

**OPERATORS AND PARTS MANUAL
MODEL 810 WOOD/BRUSH CHIPPER**



MANUFACTURER OF OUTDOOR POWER EQUIPMENT

Products for Turf & Lawn care, Rental, Construction, Tree care, Wood Processing, Nursery & Farm Industries

Other Salsco Equipment

3-1/2" - 18", Gas, Diesel, and P.T.O, Wood/Brush Chippers

Chipper Shredder Vacuum - Tailgate & Truckloader Vacuums up to 65 HP

Shaving Mills - Gas and Electric Greens Rollers

Quality of Workmanship, Innovative

Design, Built to Last!

105 School House Road

Cheshire, CT 06410 U.S.A.

800-872-5726, 203-271-1682, 203-271-2596 (Fax)

sales@salsco.com, www.salsco.com

TABLE OF CONTENTS

MODEL 810 CHIPPER

COVER & TABLE OF CONTENTS.....	Pages 1 – 2
STATEMENT OF FACT	Page 3
SPECIFICATIONS & FEATURES	Page 4
MACHINE REGISTRATION	Page 5
SAFETY & OPERATING INSTRUCTIONS	Pages 6 - 11
SERVICE & MAINTENANCE INSTRUCTIONS	Pages 12-13
PARTS DIAGRAMS	Pages 14-21
OPTIONAL SPEED SENSING DIAGRAM & CALIBRATION	Pages 22-26
TORQUE CHARTS	Page 27
WARRANTY POLICY/PROCEDURE	Page 28
COPY OF WARRANTY CLAIM FORM.....	Page 29
SERVICE SCHEDULE LOG	Page 30

SALSCO, INC.
105 School House Road
Cheshire, CT 06410
800-872-5726, 203-271-1682
203-271-2596 (Fax)
www.salsco.com, sales@salsco.com

STATEMENT OF FACT

You have just purchased the highest quality, most dependable, Chipper, on the market today. This unit has the ability to meet exact standards and perform for years with minimum downtime. **HOWEVER**, it cannot read nor will it understand this manual no matter how long you leave it on top of the machine.

It is your responsibility to read and understand this manual; it is also your responsibility to be certain this information is passed along to anyone who is expected to operate this equipment. Should you choose not to read, understand and pass along the information provided you, please expect equipment failure and possible injuries to persons around this equipment.

For the safety of the operator, it is **imperative** that this manual is carefully read and understood.

Once you have read this manual, it is your responsibility to be sure that all new operators read and understand this manual, especially all cautions stated.

As a manufacturer of equipment, we have a responsibility to design a safe piece of equipment. **NOTE:** The important safeguards and instructions in this manual are not meant to cover all possible conditions and situations that may occur. It must be understood that common sense, caution, and care are factors, which cannot be built into any product. These factors must be supplied by the person(s) caring for and operating this equipment.

ONLY YOU CAN PREVENT ACCIDENTS!!

SPECIFICATIONS & FEATURES

The Salsco Model 810 is ruggedly built to withstand high volume usage by many different industries. Rental – Tree Care – Commercial Lawn and Golf Courses, just to name a few.

Some of the standard features are heavy duty ¼” diamond plate fenders with enclosed light guards, machine vandalism kit, extra large hydraulic and fuel tanks with drain plugs, 6,000-lbs. axle, large, high speed, 28.10” diameter tires, bolt on feed hopper, two bed knives and 360° swivel chute.

The trailer frame is constructed of 2” x 4” x ¼” rectangular steel tubing, continuous weld for strength and gussets where needed. The 6,000-lb Torflex axle features an independent suspension, cushioned with rubber, providing a smoother, quieter ride with no transfer of road shock from one wheel to the other.

Model 810 has a huge 10” x 18” chipper inlet opening and a 21” diameter feed roll. This, coupled with the largest infeed hopper in the industry, 1,881 square inches, allows our machine to ingest whole trees, branches and all. Even the largest home Christmas trees are no problem. Our Model 810, because of our reel roll design, will not only handle the hard woods of the North, but the grassy palm fronds of the Southern States. This unit will handle all your chipping needs, no matter what type of tree or plant.

The feed roll receives its power through a jackshaft from a hydraulic motor. This allows a double gear reduction and thus an increase of available torque. You’ll be amazed with the smoothness and ease of this feed system.

We use two bed knives, one horizontal and one vertical, which allows our machine to cut, where others might shred.

Safety is our main concern and we have gone the extra mile. However, only you can save yourself and your employees from the danger, which lies in these machines. It is your responsibility as the buyer of this machine, to make sure the operator has been trained. Talk to your operators every day – hold classes. Do something to help yourself. We can only go so far.

MACHINE REGISTRATION

MANUFACTURED BY:

SALSCO, INC.
105 School House Rd., Cheshire, CT 06410
800-872-5726, 203-271-1682, 203-271-2596 (Fax)
sales@salsco.com www.salsco.com

THIS MANUAL COVERS MODEL (s): 810, 10" x 18" Chipper.

This company reserves the right to discontinue, add improvements to, or change the design of any model or product at any time without obligation to improve existing machines, either by changing the design or adding new parts.

It has been and will continue to be the policy of SALSCO to update existing machines at its own discretion. Whenever possible, new designs will be made in such a way that they can be "Retro Fit" if so desired.

Record in the space provided below the model and serial number of this unit. Please retain these numbers for future reference.

No parts orders will be accepted **WITHOUT MODEL NUMBERS OR PART NUMBERS**. All part numbers are listed in this manual.

Serial Number

Model Number

NOTE: Be sure to complete your warranty card. This will insure immediate processing of any warranty claims.

READ AND UNDERSTAND THIS MANUAL BEFORE STARTING THE MACHINE

1/06

CAUTIONS

READ THOROUGHLY THE OPERATOR SAFETY INSTRUCTIONS ON THE FOLLOWING PAGES WHICH ARE THE AMERICAN NATIONAL STANDARD OF POWERED SHREDDERS/GRINDERS SAFETY SPECIFICATIONS, PROVIDED BY ANSI AND THE O.P.E.I.

THE FOLLOWING COUTIONS ARE PROVIDED BY SALSCO AS A QUICK REFERENCE ONLY AND ARE NOT MEANT TO REPLACE THE PRECAUTIONS ON THE FOLLOWING PAGES.

- THINK -

1. **ALWAYS** use protective eyewear when machine is in operation.
2. **ALWAYS** use gloves and wear ear protection when machine is in operation.
3. **NEVER** put hands, legs or any part of your body into or near the chipper intake or discharge openings.
4. **NEVER** run machine with guards removed.
5. **ALWAYS** allow machine to cool off, remove key an put engine in neutral before attempting any maintenance or repair.
6. **BE SURE** machine has stopped completely, engine is off, key is removed and spark plug is disconnected before attempting any service or maintenance.
7. **NEVER** stand in front of chipper infeed hopper. It is possible for a chip or piece of wood to be thrown out.
8. **BE SURE** the machine is parked on a dry level surface before starting operation.
9. **DO NOT** operate with loose clothing or long unrestrained hair. **BE SURE** vines and branches are not wrapped around your body parts.
10. **DO NOT** operate on ice or any other slippery surface. **BE SURE** area around machine is clear and clean. You don't want to trip or fall into the machine.
11. **NEVER** leave machine running unattended, especially around youngsters or persons not instructed in the safe operation of this machine.
12. **READ** and understand federal guidelines provided with this manual on the following pages.

- IT'S YOUR HAND OR FOOT -

BRUSH CHIPPERS

ANSI Z133.1-2006

American National Standard for Arboricultural Operations Safety Requirements

5.3 Brush Chippers

- 5.3.1 The items contained in section 5.1 shall always be included in the review of this section.
- 5.3.2 Access panels (for example, guards) for maintenance and adjustment, including discharge chute and cutter housing, shall be closed and secured prior to starting the engine of brush chippers. These access panels shall not be opened or unsecured until the engine and all moving parts have come to a complete stop (see Annex C, General Safety Procedures That Apply to All Tree Work).
- 5.3.3 Rotary drum or disc brush chippers not equipped with a mechanical infeed system shall be equipped with an infeed hopper not less than 85 inches (2.15 m) measured from the blades or knives to ground level over the center line of the hopper. Side members of the infeed hopper shall have sufficient height so as to prevent workers from contacting the blades or knives during operations.
- 5.3.4 Rotary drum or disc brush chippers not equipped with a mechanical infeed system shall have a flexible anti-kickback device installed in the infeed hopper to reduce the risk of injury from flying chips and debris.
- 5.3.5 Chippers equipped with a mechanical infeed system shall have a quick-stop and reversing device on the infeed system. The activating mechanism for the quick-stop and reversing device shall be located across the top, along each side, and close to the feed end of the infeed hopper within easy reach of the worker.
- 5.3.6 Vision, hearing, and/or other appropriate personal protective equipment shall be worn when in the immediate area of a brush chipper in accordance with section 3.4, Personal Protective Equipment.
- 5.3.7 Arborists, mechanics, and other workers shall not, under any circumstances, reach into the infeed hopper when the cutter disc, rotary drum, or feed rollers are moving.
- 5.3.8 When trailer chippers are detached from the vehicles, they shall be chocked or otherwise secured in place.
- 5.3.9 When in a towing position, chipper safety chains shall be crossed under the tongue of the chipper and properly affixed to the towing vehicle.
- 5.3.10 See section 8.6, Brush Removal and Chipping, for additional requirements.

BRUSH REMOVAL AND CHIPPING

ANSI Z133.1-2006

American National Standard for Arboricultural Operations Safety Requirements

8.6 Brush Removal and Chipping

- 8.6.1 Traffic control around the jobsite shall be established prior to the start of chipping operations along roads and highways (see section 3.2, Traffic Control Around the Jobsite).
- 8.6.2 Brush and logs shall not be allowed to create hazards in the work areas.
- 8.6.3 To prevent an entanglement hazard, loose clothing, climbing equipment, body belts, harnesses, lanyards, or gauntlet-type gloves (for example, long-cuffed lineman's or welder's gloves) shall not be worn while operating chippers.
- 8.6.4 Personal protective equipment shall be worn when in the immediate area of chipping operations in accordance with section 3.4, Personal Protective Equipment, of this standard.
- 8.6.5 Training shall be provided in the proper operation, feeding, starting, and shutdown procedures for the chipper being used.
- 8.6.6 Maintenance shall be performed only by those persons authorized by the employer and trained to perform such operations.
- 8.6.7 Brush and logs shall be fed into chippers, butt or cut end first, from the side of the feed table center line, and the operator shall immediately turn away from the feed table when the brush is taken into the rotor or feed rollers. Chippers should be fed from the curbside whenever practical.
- 8.6.8 The brush chipper discharge chute or cutter housing cover shall not be raised or removed while any part of the chipper is turning or moving. Chippers shall not be used unless a discharge chute of sufficient length or design is provided that prevents personal contact with the blades (see Annex C, General Safety Procedures That Apply to All Tree Work).
- 8.6.9 Foreign material, such as stones, nails, sweepings, and rakings, shall not be fed into chippers.
- 8.6.10 Small branches shall be fed into chippers with longer branches or by being pushed with a long stick.
- 8.6.11 Hands or other parts of the body shall not be placed into the infeed hopper. Leaning into or pushing material into infeed hoppers with feet is prohibited.
- 8.6.12 While material is being fed into the chipper infeed hopper chute, pinch points continually develop within the material being chipped and between the material and machine. The operator shall be aware of this situation and respond accordingly.
- 8.6.13 When feeding a chipper during roadside operations, the operator shall do so in a manner that prevents him or her from stepping into traffic or being pushed into traffic by the material that is being fed into the chipper.
- 8.6.14 When using a winch in chipper operations, the operator shall ensure that the winch cable is properly stored before initiating chipper operations.
- 8.6.15 Refer to section 5.3, Brush Chippers, for additional information.

SAFETY DECALS

PART # 0314020

SAFETY RULES

1. DO NOT OPERATE WITH COVERS OFF.
2. KEEP HANDS & FEET AWAY!
3. DO NOT REFILL FUEL WHILE ENGINE IS HOT OR IS RUNNING!
4. READ MANUAL BEFORE OPERATING.
5. DO NOT OPERATE AROUND ANIMALS OR PEOPLE.
6. CAUTION - MACHINE CAN TURN DEBRIS INTO FLYING OBJECTS!

PART # 0314062



PART # 0314049



SAFETY DECALS

PART # 0314060



PART # 0314062



PART # 0314015



**KEEP HANDS AND
FEET AWAY**

PART # 0314063



OPERATING INSTRUCTIONS

Count your extremities before you start!
Feet, hands, fingers, etc.

1. Read the manual again.
2. Look at the finger decal and study it. These could be yours!
3. Be sure all guards are in place before starting machine.
4. Set feed handle in reverse position (push towards machine).
5. Check engine oil and fuel levels, as per engine manufacturers specifications.
6. Be sure machine is on dry, flat surface and it's secured from rolling.
HINT: Be sure machine is not too close to the woodpile. You need room to work and move around.
7. Set engine just above idle and start motor. (Be sure to check that no one is around this machine but you). If you have a diesel engine, you may have cold engine start. Refer to the engine manual.
8. With machine just over idle and after the engine has warmed up, engage the clutch slowly.
9. Check engine manual for full throttle R.P.M. and recommendations and bring your machine to that R.P.M.
10. You are ready to chip wood, as soon as you put your safety glasses and gloves on and insert earplugs.
11. Move the feed handle away from the machine. This will engage the feed roll.
12. Standing at the rear of the machine, looking at the hopper, feed the wood to the feed roll. Once the machine begins, turn and walk away from the machine. It will draw the wood in without your help. Go get another piece and repeat this procedure.
13. With large diameter pieces, it may be necessary to send in a smaller piece to start the feed roll. Also, it may be necessary to monitor R.P.M. and back off on feed speed.
14. MACHINE SHUTDOWN PROCEDURES: Bring R.P.M. down to a full idle and disengage the clutch. Let engine run a few minutes to cool down and then shut down. Chipper flywheel will still be rotating.

HINTS

1. When operating machine, stand off to the side of the feed hopper when feeding wood into the machine. NEVER STAND DIRECTLY IN FRONT OF THE FEED HOPPER WHEN FEEDING WOOD INTO THE MACHINE.
2. When using the chipper and you have a short piece of wood bouncing around and not being grabbed by the feed roll, LEAVE IT! DO NOT TRY TO PUSH IT THROUGH WITH ARMS OR LEGS! The next limb will push it through.
3. When through with the job let the engine run at full R.P.M., making sure all material is through the machine before shutting it down. This will prevent injuries from flying debris when the machine is started up at the next job.
4. COUNT YOUR EXTREMITIES AGAIN. BE SURE THIS NUMBER MATCHES YOUR STARTING NUMBER.

WHILE PERFORMING MAINTENANCE OR REPAIR, ALWAYS REMOVE KEY FROM ENGINE!

SERVICE SCHEDULE

1. **Engine & clutch adjustments** - follow service maintenance schedule set forth by the manufacturer in the engine and clutch manuals.
2. **Grease** all main bearings once a day. **DO NOT OVER GREASE.** Wipe extra grease off bearings. Bearing under guards for feed rolls need to be greased at least once a week. When removing guards, check chain tension.
3. Be sure to **clean** entire machine, especially around engine after using. Should it become necessary to remove the exhaust chute, **REMOVE KEY FROM ENGINE. NEVER TURN ENGINE OVER WHILE EXHAUST CHUTE IS REMOVED.**
4. **Sharpen/change chipper blades:** Remove key from engine and remove spark plug wires (gas engines only). Be sure throttle is in off position and clutch is disengaged. Be sure to put a red lock out tag on this machine to warn others of pending danger. Remove top pin from chipper housing access door and pivot housing open. This will allow access to impeller. Rotate impeller to a comfortable working position and tighten pusher screw against the impeller. This will lock the impeller while you service the blades. Sharpen the blades as evenly as possible and be sure you Locktite and tighten all bolts. A loose bolt coming out of this machine would be a large bullet. Should you drop a nut, bolt or blade in the housing you must retrieve it before you start up the machine. **HINT:** Salsco recommends replacement of nuts when replacing or sharpening chipper blades. The locking ability of these nuts may have been violated.
5. **Bed knife adjustment** is .070. To adjust the bed knife, remove access door on side of chip chamber and rotate impeller until blades pass in front of bed knife. Check with feeler gauge and set to .070. Repeat procedure for horizontal knife.
6. **Adjust infeed roll housing:** Remove both guards and pry housing front or rear and shim behind nylon. Tighten up and remove play.
7. **Check belt for wear and or adjustment:** Belt needs adjustment when belt is loose. Adjust belt as follows: Loosen four bolts holding engine and adjust engine to tighten bolts. You must remove the belt guard for proper access to belts.
8. **Remove infeed hopper:** Infeed hopper is removable for maintenance or storage but unit must **NEVER** be run without the hopper in place. Connect chain hoist or lifting device of some sort and remove bolts. Now hopper can be stored.
9. **Remove feed roll box:** Periodically the feed roll assembly will require disassembly. Remove the two hoses going to the drive motor (be sure to mark them for reassembly). Also, you must check the rotation of the feed roll upon reinstallation. Cap open hydraulic hoses. **Dirt is any hydraulic systems enemy.** Connect chain hoist or lifting device to feed roll box assembly and remove from machine. The feed roll can now be worked on to make necessary repairs. When replacing the feed roll box, be sure to shim behind the nylon wear strips to remove endplay.

SERVICE SCHEDULE	AS NEEDED	DAILY	WEEKLY	MONTHLY
CHECK WHEEL BEARINGS	X	-	-	X
CHECK LUG NUTS	X	-	-	-
CHECK LIGHTS	X	X	-	-
CHECK ENGINE OIL	X	X	-	-
CLEAN MACHINE	X	X	-	-
GREASE INFEED ROLL BEARING	X	-	X	-
GREASE DISC SHAFT BEARING	X	X	-	-
SHARPEN CHIPPER BLADES	X OR	-	X	-
CHECK & ADJUST BED KNIFE	X OR	-	X	-
CHECK & ADJUST ROLL HOUSING	-	-	-	X
CHECK TIRE AIR PRESSURE	X	-	-	X
CHECK ALL NUTS & BOLTS	X	X	-	-
CHECK ENGINE BELT TENSION	X	-	X	-
CHECK HYDRAULIC OIL	X	-	-	X
CHECK HYDRAULIC HOSES	X	-	-	X

NEVER, UNDER ANY CIRCUMSTANCES, START THE ENGINE WHEN UNIT IS OPEN OR AT ANY TIME DURING SERVICE OR ROUTINE MAINTENANCE

IMPELLER REMOVAL PROCEDURE

1. Remove key from engine and disconnect battery cables.
2. Remove discharge elbow.
3. Remove pin lock and pivot top housing open.
4. Remove top housing exhaust half.
5. Remove belt guard.
6. Remove hydraulic pump. Leave hoses connected, just slide out of sleeve and lay on the side.
7. Loosen engine-mounting bolts and back off slide pusher bolts. Loosen belts and remove.
8. Remove pulley from impeller shaft.
9. Remove top and bottom clevis pins from front feed wheel lift cylinder if unit is equipped with this option.
10. Loosen horizontal and vertical bed knives and slide them away from the impeller.
11. Remove chip blades from impeller. (Follow procedure in service schedule, line item # 4)
12. Connect lifting device to impeller. (Use bolt hole for chip blade and **KEEP IN MIND** – WHEN CHOOSING A LIFTING DEVICE, THE IMPELLER WEIGHS APPROXIMATELY 700-lbs.)
13. Remove bolts from both flange bearings. Back off setscrews in bearings.
14. Carefully lift impeller out of machine.
15. Remove both flange bearings and all spacers from impeller.

INSTALLATION OF IMPELLER

1. Connect suitable lifting device to impeller and set in machine. **KEEP IN MIND** – WHEN CHOOSING A LIFTING DEVICE, THE IMPELLER WEIGHS APPROXIMATELY 700-lbs. Be sure both shaft ends are clean and free from burrs. Bearing must slide freely on shaft.
2. Slide bearing on shafts and start the four bolts, rear bearing, two front bearings diagonally.
3. Tighten four bolts on rear bearing and two bolts on front bearings diagonally.
4. Slide impeller towards rear of machine. Impeller hub should touch rear-bearing race.
5. Measure distance from impeller hub and front bearing race.
6. Remove front bearing slide shims over shaft to equal that distance. **CAUTION: DO NOT ADD MORE SHIMS THAN ARE REQUIRED.** This could cause premature bearing failure. Reinstall front bearing.
7. With impeller shimmed and bearings tight, impeller should not slide front or rear.
8. Install all bearing mounting bolts with blue Loctite. Also Loctite and tighten bearing set screws.
9. Install all chip blades. Be sure to use new hardware and Loctite each time blades are removed and reinstalled. (Follow procedure in service schedule, line item #4)
10. Set bed knives and lock in place. (.070 clearance between chip blades and bed knives)
11. Reinstall top housing and discharge elbow. Be sure to use roll pin to keep housing aligned.
12. Install pulley. Be sure to use straight edge to line up pulley.
13. Install belts and adjust to specs shown in service manual with discharge chute and impeller assembly.
14. Be sure to recheck pulley with straight edge.
15. Install pump and use Loctite.
16. Install belt guard.
17. Install front lift cylinder, if so equipped.
18. Check to be sure all guards are in place and all bolts and nuts have been installed and tightened to proper specs.
19. Connect battery cables and start engine.
20. Engage clutch slowly. Start impeller and check for noise or vibration.
21. Engage impeller and bring engine up to operating R.P.M. **DO NOT START UNIT WITHOUT ALL GUARDS IN PLACE.**
22. Test lift cylinder feed wheel if so equipped.
23. Lower feed wheel and bring engine to idle.
24. Shut down engine and put machine in neutral.
25. Once machine has come to a halt, re-grease bearings.
26. Send machine to work. It's ready!

REMEMBER: REMOVE KEY FROM ENGINE, DISCONNECT BATTERY CABLES AND LOCK-OUT UNIT WHENEVER PERFORMING SERVICE AND MAINTENANCE.

**DRAWING # 1 - ASSEMBLY DETAILS
SEE DRAWING # 9 FOR HYDRAULIC SYSTEM**

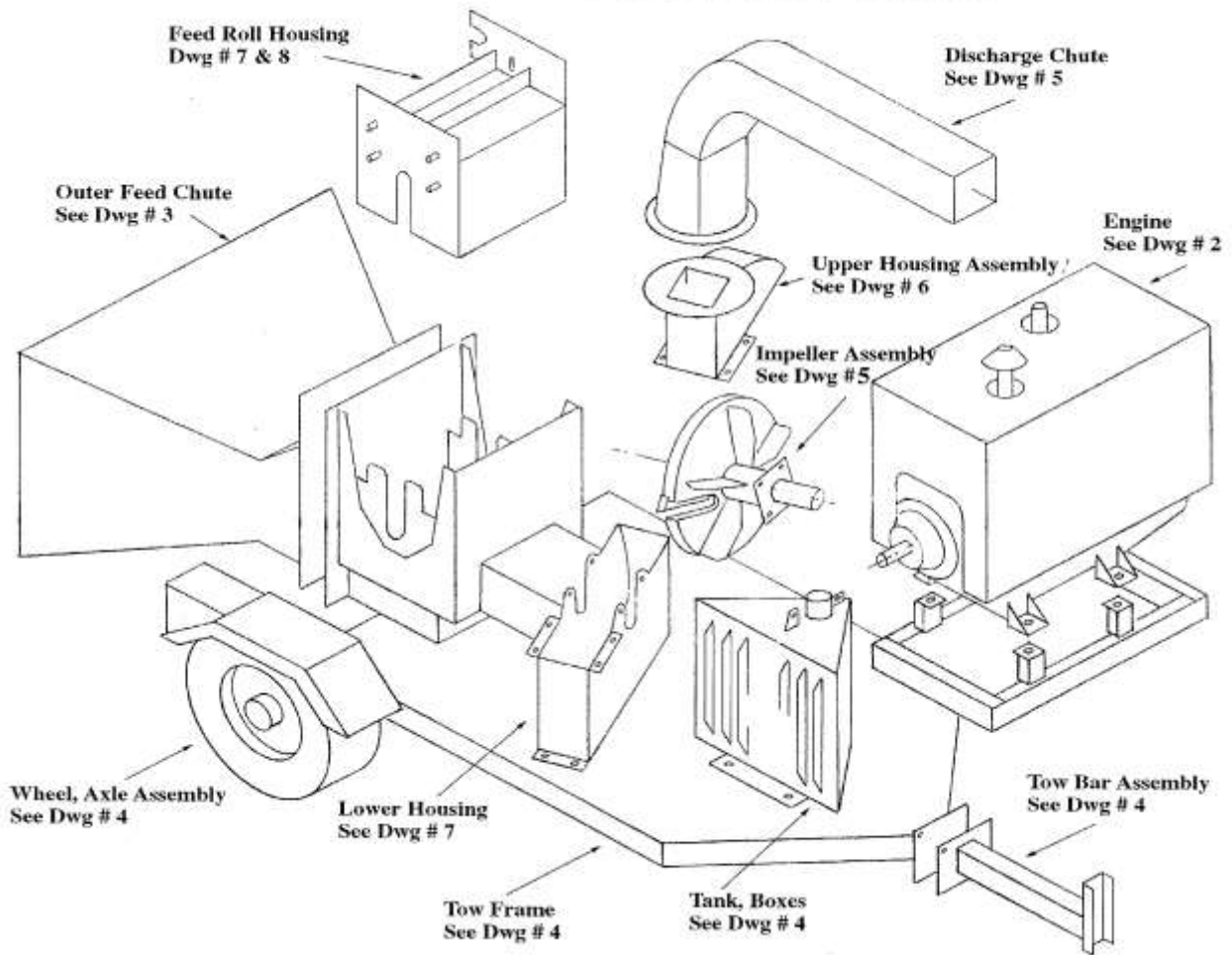

DRAWING # 2 - ENGINE

Item#	Description	Part #	Qty
1	Vandalism Kit (Optional)		1
2	Engine (See Options Below)		1
3	Clutch, PTO, Rockford	0337062	1

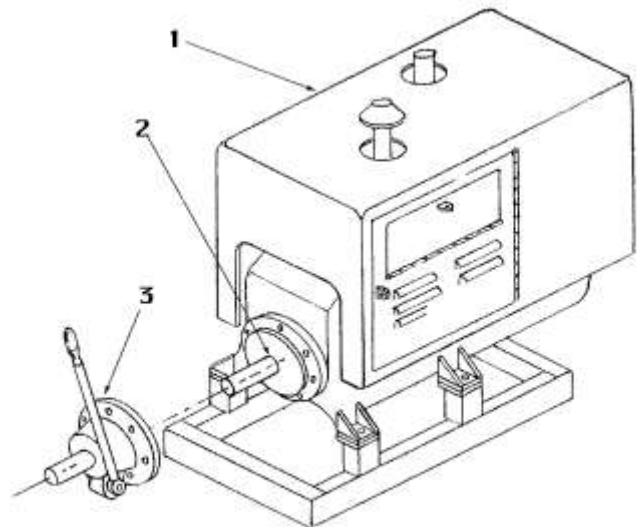

DWG # 3 OUTER FEED CHUTE ASSEMBLY			
Item#	Description	Part #	Qty
1	Wood Pusher Rod	0359007	1
2	Hopper, Infeed	0126040	1
3	Housing, Lower	0228105	1
4	Valve, Directional (see hydraulic drawing)		
5	Link, Valve Actuator	0434019	1
6	Handle, Power Feed	0223037	1

DRAWING # 3 - OUTER FEED CHUTE ASSEMBLY

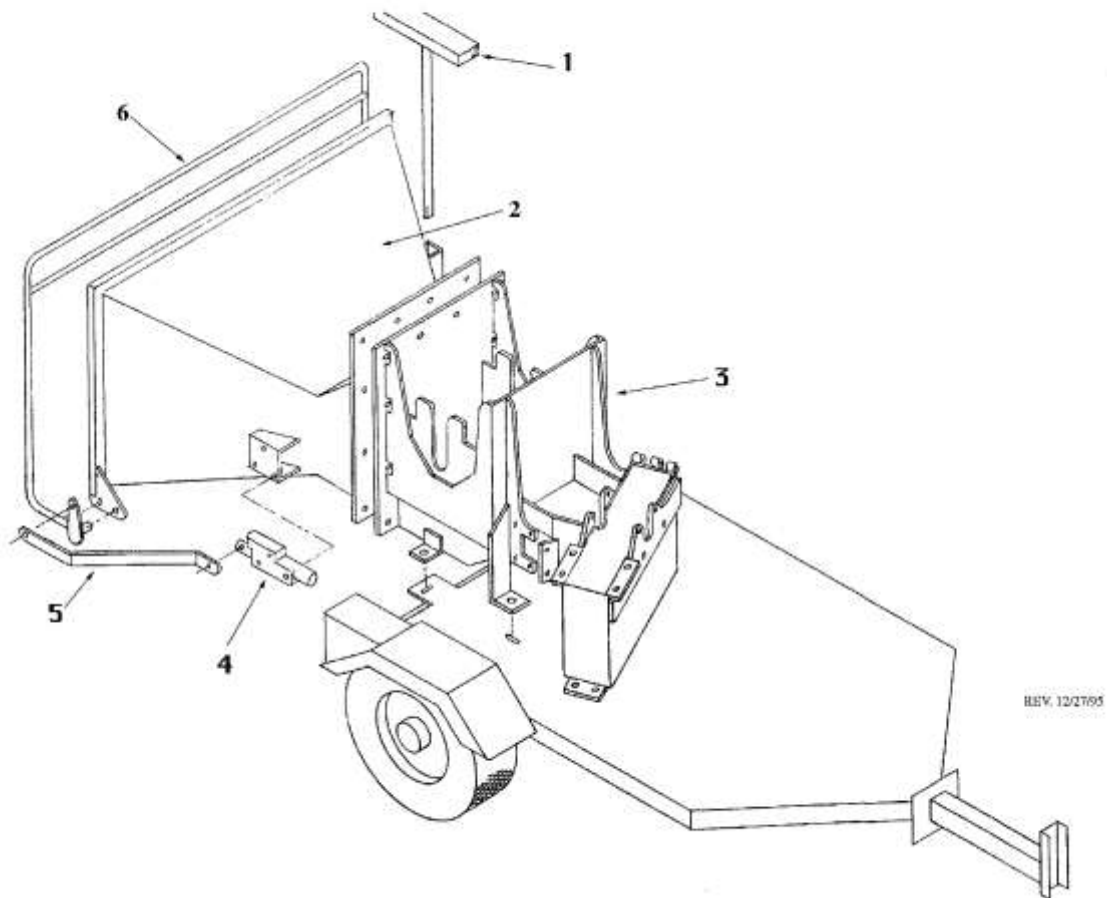

DRAWING # 4 - LOWER FRAME ASSEMBLY

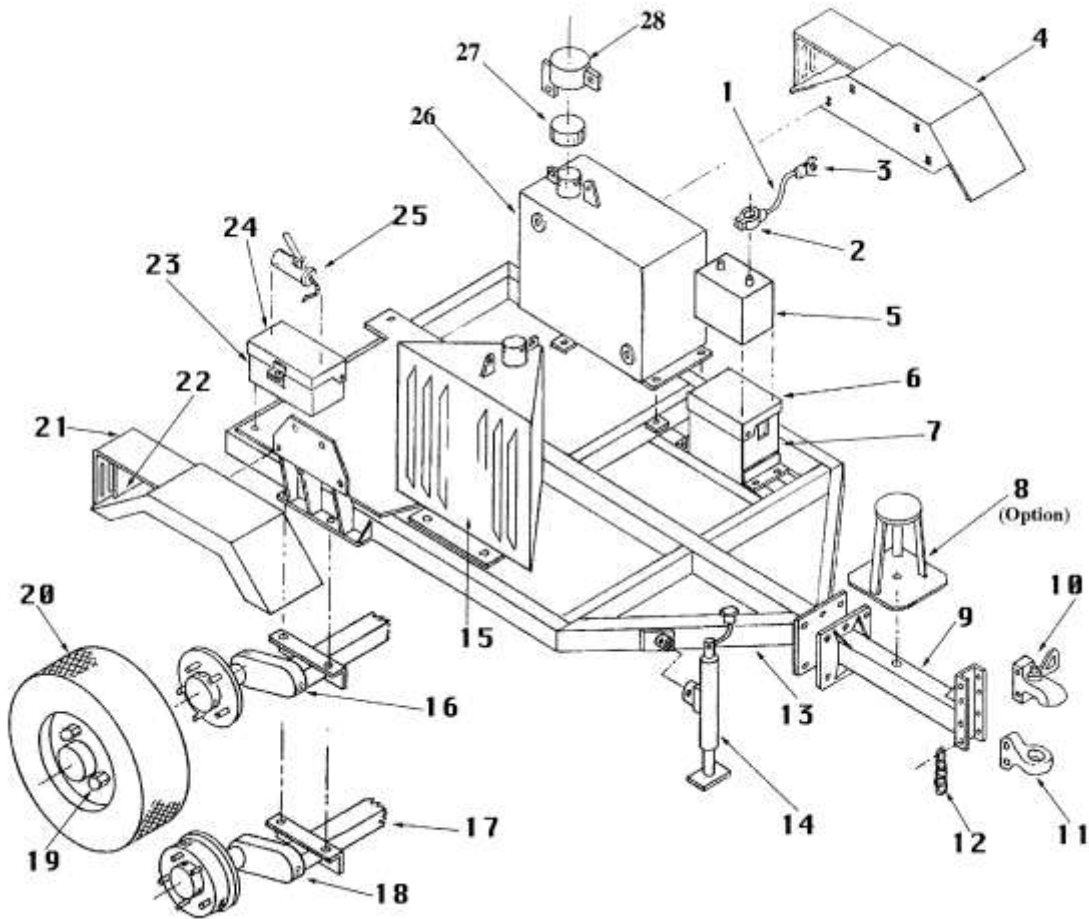

DWG # 4 – LOWER FRAME ASSEMBLY			
Item#	Description	Part #	Qty
1	Cable, Battery	0315057	2
2	Terminal, Top Post	0315058	2
3	Cable, Eyelet	0315059	2
4	Fender, Left	0216017	1
5	Battery	0315060	1
6	Cover, Battery Box	0271020	1
7	Box, Battery	0280004	1
8	Cone Holder (Opt.)	0281001	1
9	Tongue Assembly	0225019	1
10	Coupler, 2 5/16"	0325015	1
11	Coupler, Pintle (Opt.)	0325013	1
12	Chain, Safety	0309018	2
13	Tow Frame Assembly	0219072	1
14	Tongue, Jack	0369005	1

DWG # 4 – LOWER FRAME ASSEMBLY			
Item#	Description	Part #	Qty
15	Tank, Hydraulic	0152018	1
16	Axle Assembly	0302027	1
17	Axle, Assembly, Hyd. Brakes (Opt.)	0102033	1
18	Axle, Assembly, Elec. Brakes (Opt.)	0102032	1
19	Nut, Lug	0338306	10
20	Tire/Wheel Assembly	0354030	2
21	Fender, Right	0216016	1
22	Light Kit, Trailer	0361006	2
23	Box, Tool	0280002	1
24	Cover, Tool Box	0271021	1
25	Gun, Grease (Opt.)	0369004	1
26	Tank, Fuel	0152017	1
27	Cap, Fuel Tank	0271179	1
28	Cap, Locking (Hyd. and Fuel Tanks)	0271024	2

DWG # 5

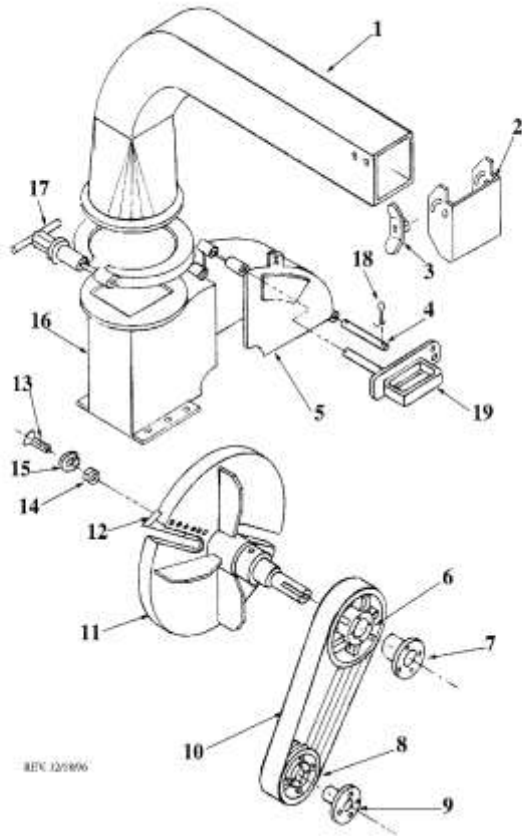

**DWG # 5 DISCHARGE CHUTE
& IMPELLER ASSEMBLY**

Item#	Description	Part #	Qty
1	Chute, Discharge	0226031	1
2	Chute, Deflector	0426028	1
3	Nut, Wing	0238500	2
4	Pin, Locking	0440034	1
5	Housing, Upper (Removable)	0228107	1
6	Pulley, SF	0342061	1
	Pulley, SF (80HP & Up)	0342073	1
7	Bushing, SF	0342062	1
8	Pulley, SK	0342063	1
	Pulley, SK (5-Groove Pulley)	0342072	1
9	Bushing, SK (Depends on size of PTO Shaft)		1
10	Belt, V	0304059	4*
*	Belt, V (37HP Wisconsin Units)	0304049	4
11	Impeller	0148073	1
12	Blade, Chipper	0305047	4
13	Bolt	0346491	12
14	Nut	0338154	12
15	Washer	0353017	12
16	Housing, Upper (Fixed)	0228106	1
17	Wing Nut, Discharge Chute	0238501	2
18	Pin, Cotter	0340004	2
19	Pin, Locking Housing	0240033	1

NOTE: Belt change, Item # 10 to Part # 0304059. Belts are retrofit. To use new belt size, loosen motor mounting bolts and slide motor to put belts on. **DON'T** pry belts with screw driver as it will damage belts

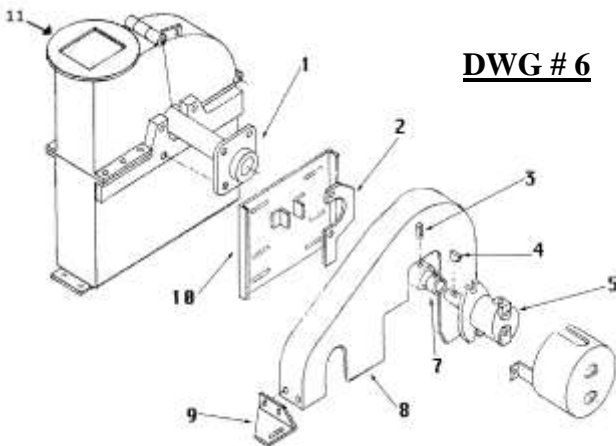

DWG # 6

**DWG # 6 - UPPER HOUSING ASSEMBLY
DIRECT DRIVE PUMP MOUNTING**

Item#	Description	Part #	Qty
1	Bearing, 3" I.D.	0303035	2
2	Bracket, Hyd. Pump	0406289	1
3	Screw, Set	0346076	2
4	Key, Woodruff	0331502	1
5	Pump, Hydraulic	0330099	1
7	Bushing, Hyd. Pump Mtg.	0407014	1
8	Guard, Impeller	0221098	1
9	Bracket, Guard Support	0477016	1
10	Mount, Belt Guard	0276086	1
11	Bearing 3" I.D.	0303035	2

DWG # 7 - LOWER HOUSING			
Item#	Description	Part #	Qty
1	Bed Knife, Horizontal	0405045	1
	Bed Knife, Horizontal After S/N 1101	0405111	1
2	Bed Knife, Vertical	0405046	1
	Bed Knife, Vertical After S/N 1101	0405099	1
3	Bar, Vertical Blade Pusher	0470048	1
4	Cover, Access (Bed Knives)	0471027	1

DRAWING # 7 - LOWER HOUSING

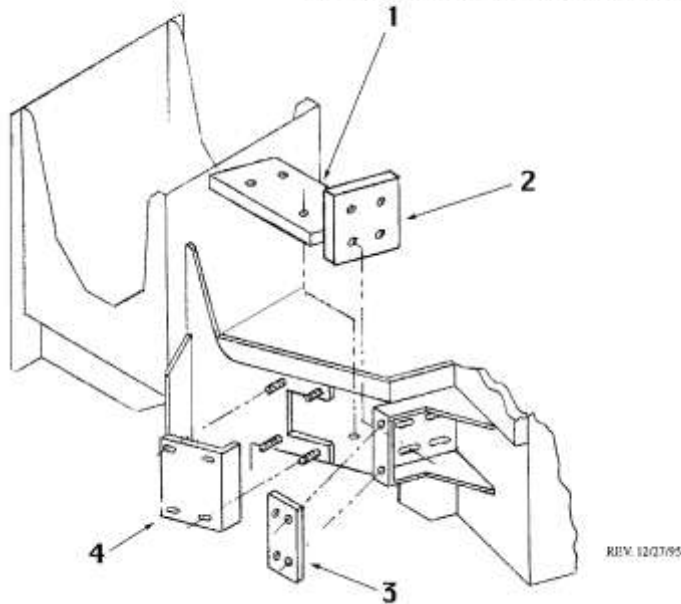

BED KNIVES POSITION ILLUSTRATION

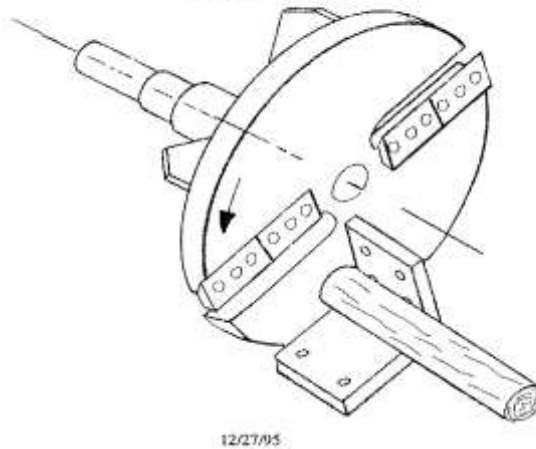

DWG # 8 - FEED ROLL HOUSING

Item#	Description	Part #	Qty
1	Roll, Power Feed	0254032	1
2	Yoke, Feed Roll	0274008	1
3	Guard, Idler Feed Roll Chain	0221097	1
4	Bar, Wear (UVMW)	0470050	4
5	Bar, Retainer	0470051	1
6	Mount, Hydraulic Motor	0476059	1
7	Support, Wear Bar	0477014	4
8	Bearing, (4) Bolt Flange	0303002	2
9	Bearing, (2) Bolt Flange	0303031	2
10	Sprocket, 1" I.D.	0351023	1
11	Sprocket Assembly	0251042	1
	Sprocket with Welded Collar	0251051	1
	Sprocket Only	0251050	1
12	Shaft & Sprocket Weldment	0248082	1
14	Sprocket Assembly	0251040	1
15	Spacer, Sprocket	0449074	1
18	Chain, 71 Pitches, # 50 H	0309023	1
19	Chain, 61 Pitches, # 50 H	0309024	1

DWG # 8 - FEED ROLL HOUSING

Item#	Description	Part #	Qty
20	Link, Master, # 50	0309033	2
21	Link, Half, # 50	0309034	2
22	Motor, Hydraulic	0330144	1
23	Shim, 16 GA.	STOCK	
24	Shim, 11 GA.	STOCK	
25	Shim, 7 GA.	STOCK	
26	Guard, Drive Feed Roll Chain	0221096	1

FOR S/N'S 00563-00626 NOTE CHANGES BELOW

Item#	Description	Part #	Qty
18	Chain, 75 Pitches, # 50 H	0309025	1
19	Chain, 60 Pitches, # 50 H	0309026	1

FOR S/N'S 0000627 & UP USE PART #'S AS LISTED BELOW

Item#	Description	Part #	Qty
12	Shaft & Sprocket Assy.	0248093	1
18	Chain, # 80	0309071	1
20	Link, Master # 80	0309038	1
21	Link, Half # 80	0309039	1

DRAWING # 8 - FEED ROLL HOUSING

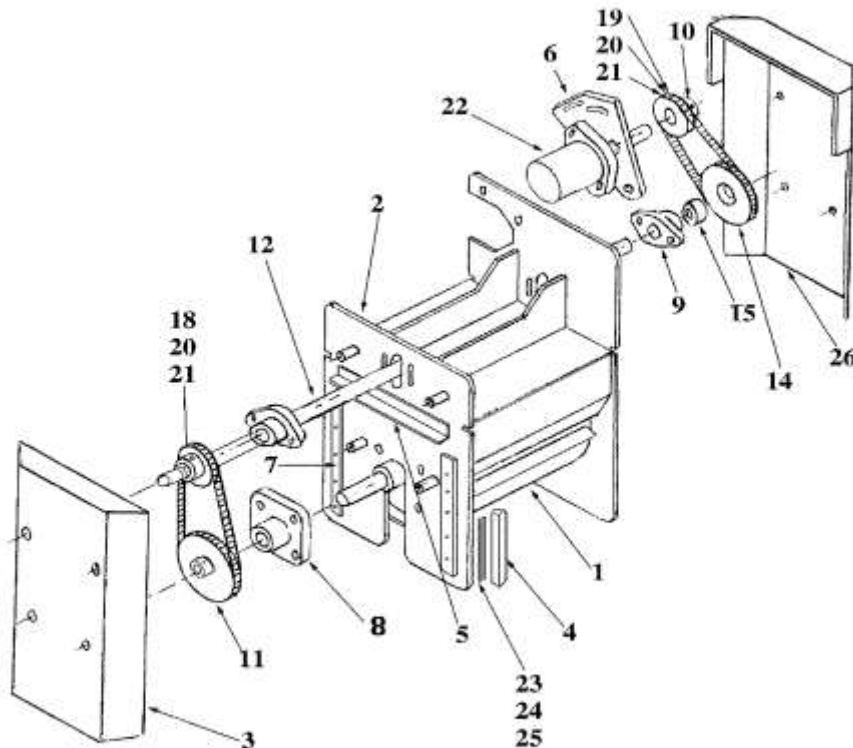

**FLOW CONTROL OPTION
MODEL 810 CHIPPER**

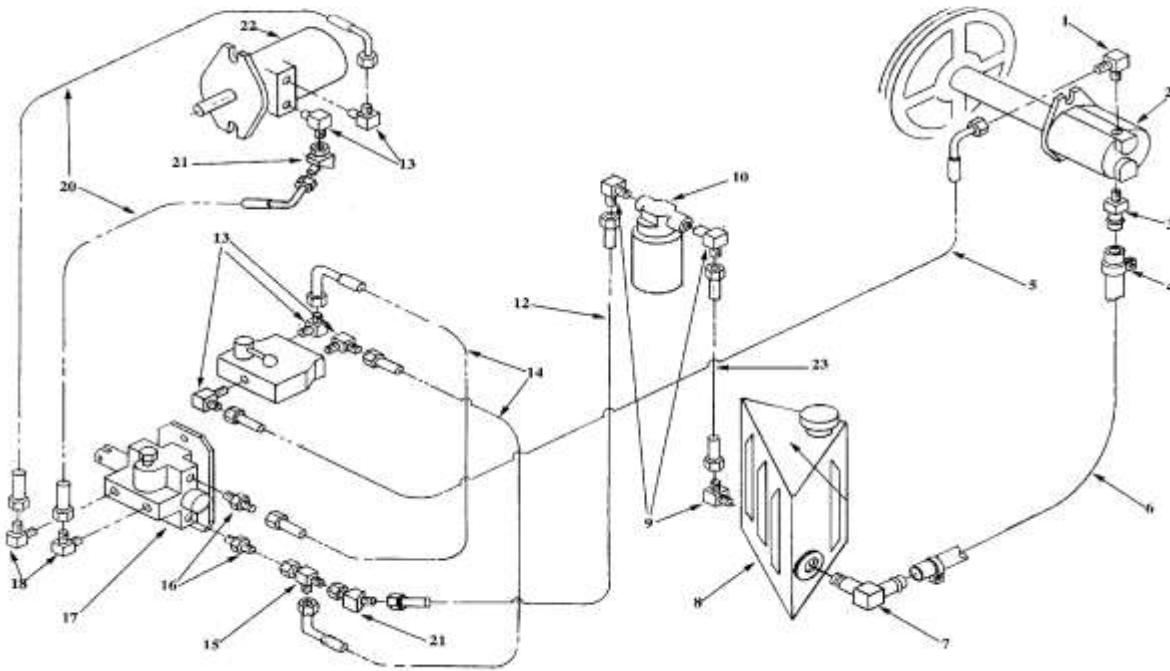

FLOW CONTROL OPTION MODEL 810			
Item#	Description	Part #	Qty
1	Adapter, 90° Elbow	0317079	1
2	Pump, Hydraulic	0330039	1
3	Connector, Straight	0317109	1
4	Clamp, Hose	0310031	2
5	Hose, ½" I.D. x 118" Long	0327085	1
6	Hose, 1" I.D. x 48" Long	0327079	1
7	Adapter, 90° Elbow	0317081	1
8	Tank, Hydraulic Oil	0252079	1
9	Adapter, 90° Elbow	0317040	3
10	Filter & Housing	0318022	1
10A	Filter Element	0318023	1
12	Hose, ½" I.D. x 56" Long	0327096	1
13	Adapter, 90° Elbow	0317052	2
14	Hose ½" I.D. x 22" Long	0327099	2
15	Tee, Swivel Run	0317118	1
16	Adapter, Straight	0317066	2
17	Valve, Directional	0330044	1
18	Adapter, 90° Elbow	0317064	2
19	Valve, Flow Control	0330083	1
20	Hose, ½" I.D. x 78" Long	0327105	2
21	Adapter, 45° Elbow	0317033	2
22	Motor, Hydraulic	0330140	1
23	Hose, ½" I.D. x 24" Long	0330040	1

SPEED SENSING CALIBRATION

CAL #	
2	627XT
	6210XT
	824
	8416/25
	8635/40
30	826
	8625
	810 } "SMALL" HYD. LIFT CYLS 0330052-N (BEFORE S/N 1519)
	810PTO }
22	810 } "LARGE" HYD. LIFT CYLS 0330053-N (AFTER S/N 1520)
	810PTO }
40	813
	813XT
	818
	818XT

Setting Speed Sensing

1. **Set the Calibration**
 - A. **Find the Mag Pick-Up. It is either on the bell housing or on the impeller shaft.**
 - a. **If it is on the Bell Housing call factory with engine model number, and ask for the number of teeth on the flywheel. That number must be set as the calibration number.**
 - b. **If the Mag Pick-Up is on the Impeller Shaft return to the chart above and plug the calibration number into the meter.**
 - B. **Turn on power to the dial and the meter will light up. You should see a zero with a dot in the lower right side of the meter. The dot means the Feed Sensing is on.**
 - a. **Press and hold until the meter gets dark then release the left button. You will see the meter read "auto feed off" and the dot will disappear.**
 - b. **Press and hold the right button until the meter gets dark then release the button "auto feed on" and the dot will appear again.**
 - C. **Now hold both buttons in together until the screen is dark and let them go. You will see CAL (and a #). At this time, press the left button to lower the number or the right to raise the number until the number of choice appears. Now press both buttons to say "OK". Keep pressing both buttons until you get back to the zero with a dot.**

Setting Speed Sensing (Continued)

- D. You have just told the machine each time you count the number in the Calibration window that equals one R.P.M.**

2. Setting the Hi & Low

- A. Start the machine and raise to full R.P.M. (be sure to engage the clutch so that the impeller is turning)**
- B. Make a note of the number you see in the meter at full R.P.M. This is "No Load R.P.M"**
- C. Shut the machine down.**
- D. Press and Hold both buttons until the meter gets dark and change the Hi & Lo to the following numbers.**
- E. Change the Hi to be 100 less than the "No Load R.P.M."**
- F. Change the Lo to be 100 less than the Hi.**
- G. All the other settings are set to zero.**
- H. Except machines with auto reverse on these machines set the back to .250.**

Auto-Feed Gold™

For ALL applications Including Kohler

OPERATING INSTRUCTIONS

PLEASE READ BEFORE OPERATING

Every effort had been made to make this manual and instructions as easy to read as possible. Please contact your dealer if you have any questions. This device is preset at the factory with John Deere settings. Below is a sample of the menu options covered in this manual.

MENU—SIX STEPS & Hour

All Functions May Be Programmed While Engine is RUNNING!

To check the hours, simply press and release either button.

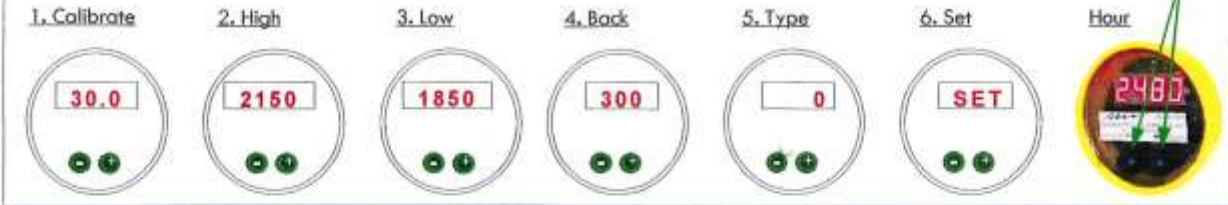

- To protect against accidental entry, the user must go through all SIX steps or program will not set.
- If, after starting to set the unit, no entries are made after 7 seconds, the unit will go back to the last program setting.
- So, if you make a mistake, not to worry, it will just go back to the last set program. If you need help, just call!

Step One—Calibration



- Press and hold BOTH push buttons until you see "HOUR," the amount of hours, then a blank display (about 4 seconds).
- Now release the buttons. You will see "CAL" displayed then a CAL number.

Enter the Calibration Number (1-200)



- After step one, press the RIGHT button to increase the number, press the LEFT button to decrease the number shown in the read-out.
- For the Kohler engine, "CAL" is 9.1.
- Check engine guide on back when programming

Step Four—Setting the Reverse Time

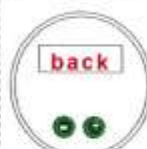

- Press and release both buttons again.
- You will now see back displayed.

Entering the Reverse Time

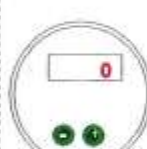

- Enter the desired reverse time or 0 (zero) if reverse is not used.* If your machine does not have reverse, it must be set to 0 (zero).
- Reverse time guidelines:
250 = 1/4 of a second
500 = 1/2 of a second

Step Two—Setting the HI Limit

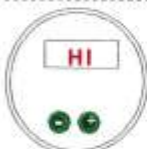

- Press and release both buttons again.
- You will now see HI displayed.

Enter the HI or Feed On RPM number by:



- Pressing the RIGHT button to increase the number in the read-out, OR
- Press the LEFT button to decrease the number.

Step Five—Setting TYPE (Reversing or Non-Reversing)

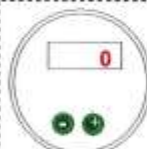

- Press and release both buttons again.
- You will now see "TYPE" displayed.
- Enter TYPE 0 or 1
- Use TYPE 0 for standard Auto-feed.
- Use TYPE 1 for new style reverse.

Step Six—Exit Program Mode



- Press both buttons again, now display will read SET! Unit is now programmed

Step Three—Setting the Lo Limit

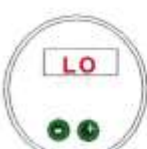

- Press and release both buttons again.
- You will now see Lo displayed.

Enter the Lo or Feed Off RPM number by:



- Pressing the RIGHT button to increase the number in the read-out, OR
- Press the LEFT button to decrease the number.

Turning your Auto-Feed On or Off

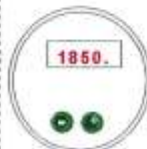

- If you need to turn your auto feed off, simply press and hold the left button for 4 seconds, then release.
- To turn it back on, press and hold the right button for 4 seconds.



Revised March 17, 2004

© 2003 Electronic Solutions Of Harrison, LLC

ITEM	DESCRIPTION	PART NO	QTY
1	TACHOMETER WITH WIRING HARNESS	0315250	1
2	MAGNETIC PICK-UP	0315128	1
3	SOLENOID VALVE, NORMALLY OPEN	0330080	1
4	SOLENOID VALVE, NORMALLY CLOSED	0330081	1
5	DIRECTIONAL CONTROL VALVE	0330121	1

ISSUED: 11-03-2008

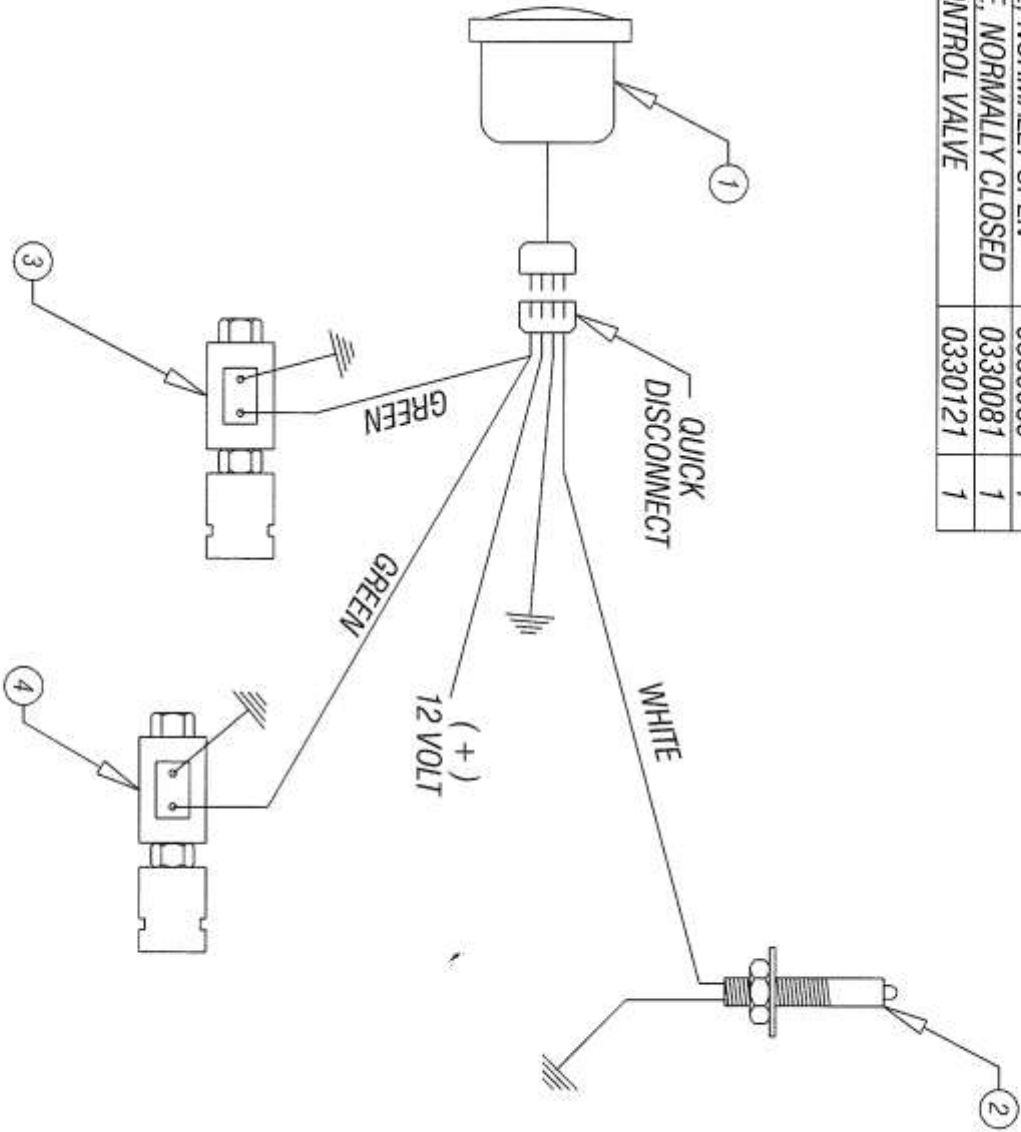

810 CHIPPER - WIRING DAIGRAM FOR SPEED SENSING OPTION

ITEM	DESCRIPTION	PART NO	QTY
1	MAGNETIC PICK-UP	0315128	1
2	SPROCKET, SPEED SENSING	0351057	1
3	LOCK WASHER	0353005	1
4	HEX HEAD SCREW, 1/2-13 x 1.5 LG	0346404	1

ISSUED: 11-03-2008

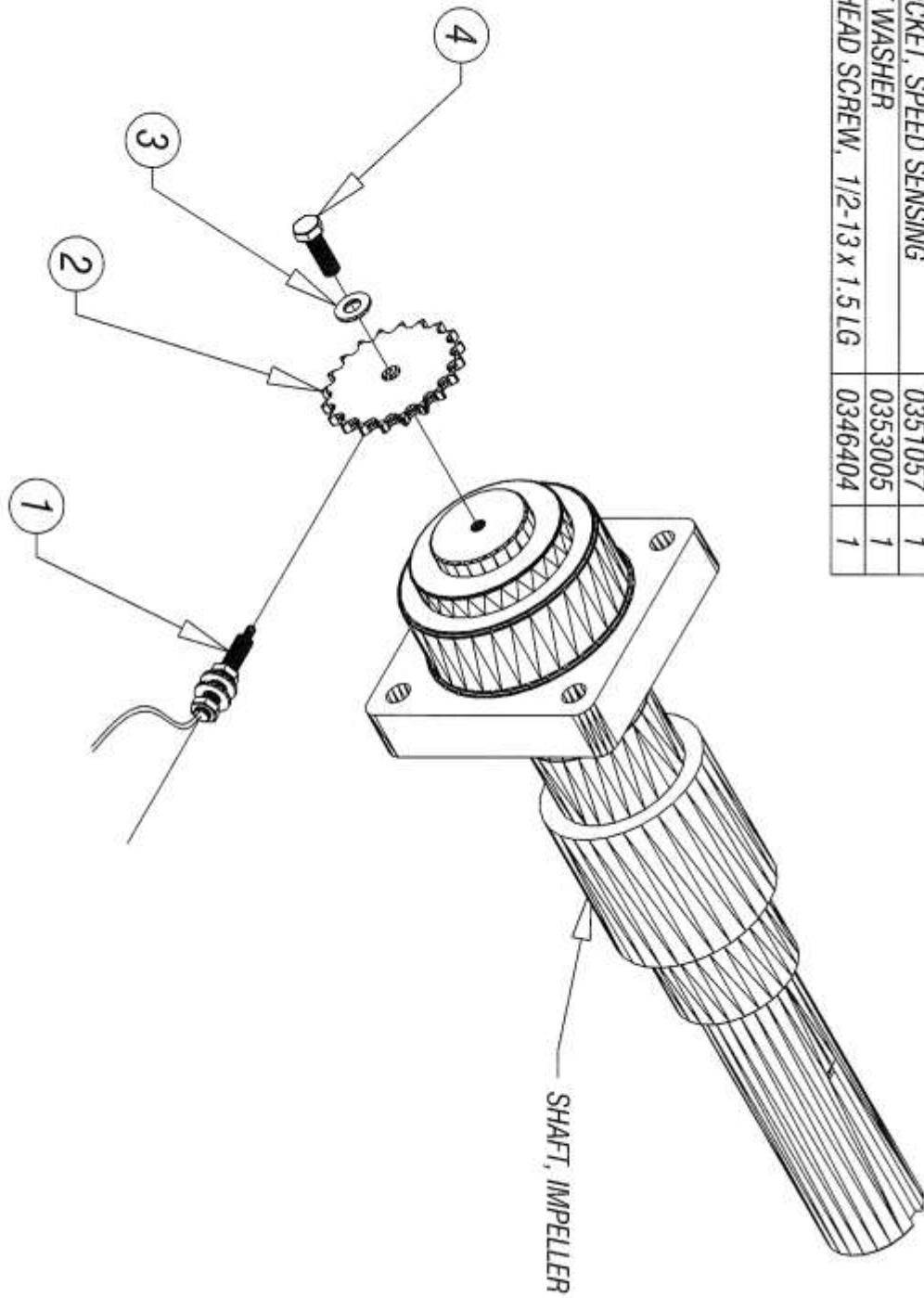

810 CHIPPER - SPEED SENSING OPTION

Below is a quick reference chart for various “Flat Head Cap Screws” and the torque recommendations.

VALUES ARE STATED IN FOOT POUNDS

BOLT SIZE	Thds Per Inch	SAE Grade 5	SAE Grade 8
1/4	20	10	14
	28	---	---
5/16	18	19	29
	24	---	---
3/8	16	33	47
	24	---	---
7/16	14	54	78
	20	---	---
1/2	13	78	119
	20	---	---
9/16	12	114	169
	18	---	---
5/8	11	154	230
	11	---	---
3/4	10	257	380
	10	---	---
7/8	9	382	600
	9	---	---
1	8	587	700
	8	---	---

Drive Belt Tension Measurement by Deflection

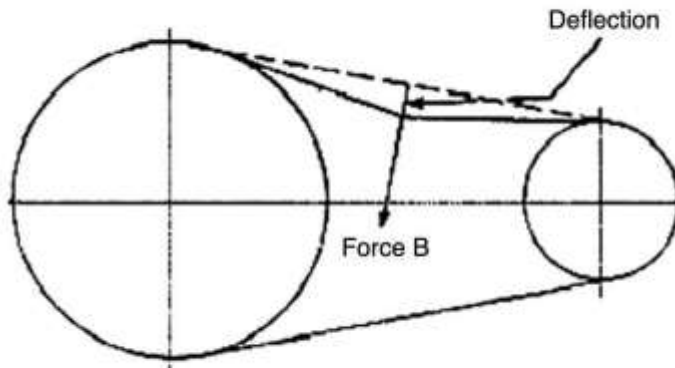

Deflection should be 3/8" when 8-12 lbs. push is applied at "B"

WARRANTY POLICY

Please remember to complete and return your Warranty Card and Dealer Delivery Report. Warranty Claims will not be considered if the Warranty Card and Dealer Delivery Report have not been returned to Salsco.

Your Salsco Commercial or Turf Equipment product is a commercial type product and is normally manufactured and sold for commercial or industrial use. **Salsco will, for the original purchaser, for one (1) year from the date of purchase (90 days if used for rental purposes) repair or replace, free of charge, any SALSCO part or parts found to be defective in material, workmanship or both.** Any transportation or shipping charges will be borne by the purchaser. If, during the warranty period stated above, the product does not function properly due to defect, simply contact Salsco and follow the Warranty Procedures included in this manual.

This warranty **does not** include:

- Incidental or consequential damages and is exclusive of any implied warranties.
- Normal maintenance parts, including, but not limited to hoses, chains, belts, filters, lubricants, etc.
- Parts or components, which are covered under the original manufacturer warranty, including, but not limited to engines, pumps, and motors.

WARRANTY PROCEDURE

In order for Salsco to consider your warranty claims in a timely manner you must follow the simple procedures listed below:

MACHINE OR PART FAILURE

- a) Call our service department for helpful instruction on how to correct or repair the problem. Preventive maintenance will also be suggested.
- b) When ordering parts for Warranty issues, you **MUST** retain possession of the old parts in question until notified with respect to returning the parts to Salsco or other disposition.
- c) Warranty Claims **MUST** be filed within 30-days from completion of the work performed. Contact our office for an electronic warranty claim form.
- d) Fill in all information requested on warranty claim form, a copy of which is included in this manual, (date of purchase, company name, address, etc.). List all parts used. Make sure part numbers are correct. You can obtain these from your manual. (include good description of problem; i.e. "leaking from spool" rather than "leaking").
- e) It is our goal to consider and reach a disposition on each Warranty Claim within 30-days from the date that it is received. Therefore it is important that you respond promptly to any request for further information. Claims with no response to inquiries will be closed as "**denied for lack of response**" 90-days from the date of request.
- f) Email, Fax or Send Warranty Claim form to our Warranty Department. – **Warranty on parts most often requires return of the parts that were replaced.** DO NOT DISCARD OLD PARTS UNTIL YOU HAVE RECEIVED A DETERMINATION AS TO WHETHER THESE PARTS MUST BE RETURNED.
- g) Our Warranty Department will contact and instruct you on how to return the Parts to Salsco on an RA #. Returns **MUST** be made within 30-Days from issuance of RA #. **FREIGHT CHARGES ON RETURN OF PARTS IS THE RESPONSIBILITY OF THE CUSTOMER.** Normal pre-delivery adjustments are not covered under warranty. Labor Warranties are based on reasonable time allowances as determined by Salsco, Inc. and paid at 75% of posted labor rate. **TRAVEL TIME IS NOT REIMBURSED UNDER THE WARRANTY POLICY.**
- h) Be sure to put the RA form inside the box that you are shipping back, also be sure to put on the outside of the box "Return of Goods" and the RA #.
- i) Ship returns via a traceable method such as UPS Ground Service. Be sure that the shipment is insured for the appropriate value. If uninsured parts are lost, we cannot issue a credit.

PLEASE NOTE: ***Warranty forms should be filled out completely.***

PREVENTIVE MAINTENANCE IS YOUR BEST INSURANCE AGAINST EQUIPMENT FAILURE. BE SURE TO READ THIS MANUAL, ESPECIALLY THE MAINTENANCE, OPERATING AND CAUTION SECTIONS.

**SALSCO, INC., 105 School House Rd.
Cheshire, CT 06410
800-872-5726, 203-271-1682
203-271-2596 (Fax)
sales@salsco.com, www.salsco.com**

WARRANTY CLAIM FORM

SALSCO, INC.
105 School House Rd.
Cheshire, CT 06410

Phone:(203) 271-1682,(800) 872-5726
Fax: (203) 271-2596
Email: s.clark@salsco.com
Website: www.salsco.com

END OWNER

Date Submitted:

Name:	Phone:	Work Order #:
Email:	Fax:	Office Use Only
Address:		Date Rec'd
		Cust ID:
		Salsco WC
		Salsco RA

PURCHASED FROM

Name:	Phone:	Date Approved:
Email:	Fax:	Date Rejected:
Address:		Processed By:
		Dir. Del Report on File: YES NO
		Warranty Card on File: YES NO
		Part(s) Total:
		Labor Total:

Equipment/Warranty Information (Must be complete)

Purchase Date:	Invoice #	Date Failed:	Total Approved:
Model #:	Serial #:	Repair Date:	Approved/Rejected:
Hrs Used:	Primary Use:		Name:
Warranty Claim/Work Order#:			Reason for Rejection:
Was a Salsco Return Authorization # issued for repairs or			
Return of Parts? YES NO			Suggested Preventative Maint:
Probable Cause of Failure:			

Work Performed/Comments on Repair:

Shop Labor Rate:		Submitted By:		
Total Labor Hours to Repair:		Printed Name:		
Parts Required for repair				
Salsco Part #: Description:	Qty.	Price Each	Total	Inv #
			\$	
			\$	
			\$	
			\$	

Fill in all information requested on warranty claim form.
INCOMPLETE FORMS CANNOT BE PROCESSED & WILL BE RETURNED
List all parts used. Make sure part numbers are correct. Any parts that you believe to be defective or any parts that break should be retained for possible inspection until after the warranty has been paid or part has been replaced.

