

**Salsco, INC.**  
LEADER BY DESIGN

MADE IN THE U.S.A

OPERATORS AND PARTS MANUAL  
MODEL 810PTO CHIPPER



**MANUFACTURER OF OUTDOOR POWER EQUIPMENT**

Products for Turf & Lawncare, Rental, Construction, Tree care, Wood Processing, Nursery & Farm Industries

*Other Salsco Equipment*

**3-1/2" - 18", Gas, Diesel, and P.T.O, Wood/Brush Chippers  
Chipper Shredder Vacuums - Tailgate & Truckloader Vacuums  
Shaving Mills - Gas and Electric Greens Rollers**

***Quality of Workmanship, Innovative  
Design, Built to Last!***

105 School House Road  
Cheshire, CT 06410 U.S.A.  
800-872-5726, 203-271-1682, 203-271-2596 (Fax)  
sales@salsco.com, www.salsco.com

**TABLE OF CONTENTS**

**MODEL 810PTO DESCRIPTION**

COVER & TABLE OF CONTENTS.....Pages 1 – 2

STATEMENT OF FACT ..... Page 3

SPECIFICATIONS & FEATURES .....Page 4

MACHINE REGISTRATION .....Page 5

SAFETY & OPERATING INSTRUCTIONS .....Pages 6 - 9

SERVICE & MAINTENANCE INSTRUCTIONS .....Pages 10 - 11

PARTS DIAGRAMS .....Pages 12 - 33

TORQUE CHART .....Page 34

WARRANTY POLICY & PROCEDURE .....Page 35

COPY OF WARRANTY CLAIM FORM.....Page 36

SERVICE SCHEDULE LOG .....Page 37

**SALSCO, INC.**  
105 School House Road  
Cheshire, CT 06410 USA  
800-872-5726, 203-271-1682  
203-271-2596 (Fax)  
[www.salsco.com](http://www.salsco.com), [sales@salsco.com](mailto:sales@salsco.com)

## **STATEMENT OF FACT**

You have just purchased the highest quality, most dependable, Chipper on the market today. This unit has the ability to meet exact standards and perform for years with minimum downtime. **HOWEVER**, it cannot read nor will it understand this manual no matter how long you leave it on top of the machine.

It is your responsibility to read and understand this manual; it is also your responsibility to be certain this information is passed along to anyone who is expected to operate this equipment. Should you choose not to read, understand and pass along the information provided you, please expect equipment failure and possible injuries to persons around this equipment.

For the safety of the operator, it is imperative that this manual is carefully read and understood.

Once you have read this manual, it is your responsibility to be sure that all new operators read and understand this manual, especially all cautions stated.

As a manufacturer of equipment, we have a responsibility to design a safe piece of equipment. NOTE: The important safeguards and instructions in this manual are not meant to cover all possible conditions and situations that may occur. It must be understood that common sense, caution, and care are factors, which cannot be built into any product. These factors must be supplied by the person(s) caring for and operating this equipment.

**ONLY YOU CAN PREVENT ACCIDENTS!**

## **SPECIFICATIONS & FEATURES**

The Salsco Model 810PTO is ruggedly built to withstand high volume usage by many different industries. Tree Care, Commercial Lawn, Christmas Tree Farms, and Golf Courses, just to name a few.

Some of the standard features are heavy duty  $\frac{1}{4}$ " diamond plate fenders with enclosed light guards, machine vandalism kit, extra large hydraulic tank with drain plugs, 6,000-lbs. axle, large, high speed, 28.10" diameter tires, bolt on feed hopper, two bed knives and 360° swivel chute.

The trailer frame is constructed of 2" x 4" x  $\frac{1}{4}$ " rectangular steel tubing, continuous weld for strength and gussets where needed. The 6,000-lb Torflex axle features an independent suspension, cushioned with rubber.

The Model 810PTO has a large 10" x 18" chipper inlet opening and a 21" diameter feed roll. This, coupled with the largest infeed hopper in the industry, 1,881 square inches, allows our machine to ingest whole trees, branches and all. Even the largest home Christmas trees are no problem. The Model 810PTO, because of our feed roll design, will not only handle the hard woods of the North, but the grassy palm fronds of the Southern States. This unit will handle all your chipping needs, no matter what type of tree or plant.

The feed roll receives its power through a jackshaft from a hydraulic motor. This allows a double gear reduction and thus an increase of available torque. You'll be amazed with the smoothness and ease of this feed system.

We use two bed knives, one horizontal and one vertical, which allows our machine to cut, where others might shred.

Safety is our main concern and we have gone the extra mile. However, only you can save yourself and your employees from the danger, which lies in these machines. It is your responsibility as the buyer of this machine, to make sure the operator has been trained. Talk to your operators every day – hold classes. Do something to help yourself. We can only go so far.

## MACHINE REGISTRATION

MANUFACTURED BY:

SALSCO, INC.  
105 School House Rd., Cheshire, CT 06410  
800-872-5726, 203-271-1682, 203-271-2596 (Fax)  
[sales@salsco.com](mailto:sales@salsco.com) [www.salsco.com](http://www.salsco.com)

THIS MANUAL COVERS MODEL (s): 810PTO Wood/Brush Chipper

This company reserves the right to discontinue, add improvements to, or change the design of any model or product at any time without obligation to improve existing machines, either by changing the design or adding new parts.

It has been and will continue to be the policy of SALSCO to update existing machines at its own discretion. Whenever possible, new designs will be made in such a way that they can be "Retro Fit" if so desired.

Record in the space provided below the model and serial number of this unit. Please retain these numbers for future reference.

**NO PARTS ORDERS** will be accepted **WITHOUT MODEL NUMBERS OR PART NUMBERS.** All part numbers are listed in this manual.

\_\_\_\_\_  
Serial Number

\_\_\_\_\_  
Model Number

NOTE: Be sure to complete your warranty card. This will insure immediate processing of any warranty claims.

**READ AND UNDERSTAND THIS MANUAL BEFORE STARTING THE MACHINE**

1/06

## **CAUTIONS**

READ THOROUGHLY THE OPERATOR SAFETY INSTRUCTIONS ON THE FOLLOWING PAGES WHICH ARE THE AMERICAN NATIONAL STANDARD OF POWERED SHREDDERS/GRINDERS SAFETY SPECIFICATIONS, PROVIDED BY ANSI AND THE O.P.E.I.

THE FOLLOWING CAUTIONS ARE PROVIDED BY SALSCO AS A QUICK REFERENCE ONLY AND ARE NOT MEANT TO REPLACE THE PRECAUTIONS ON THE FOLLOWING PAGES.

### **- THINK -**

1. **ALWAYS** use protective eyewear when machine is in operation.
2. **ALWAYS** use gloves and wear ear protection when machine is in operation.
3. **NEVER** put hands, legs or any part of your body into or near the chipper intake or discharge openings.
4. **NEVER** run machine with guards removed or shaft cover removed.
5. **ALWAYS** allow machine to cool off, BE SURE machine has stopped completely, and disconnect drive shaft from the tractor before attempting any maintenance, or repair.
6. **NEVER** stand in front of chipper infeed hopper. It is possible for a chip or piece of wood to be thrown out.
7. **BE SURE** the machine and tractor is parked on a dry level surface before starting operation.
8. **DO NOT** operate with loose clothing or long unrestrained hair. **BE SURE** vines and branches are not wrapped around your body parts.
9. **DO NOT** operate on ice or any other slippery surface. **BE SURE** area around machine is clear and clean. You don't want to trip or fall into the machine.
10. **NEVER** leave machine running unattended, especially around youngsters or persons not instructed in the safe operation of this machine.
11. **READ** and understand federal guidelines provided with this manual on the following pages.

**REMEMBER – IT'S YOUR HAND OR FOOT!**

**BRUSH CHIPPERS**  
**ANSI Z133.1-2006**  
American National Standard for Arboricultural Operations  
Safety Requirements

**5.3 Brush Chippers**

- 5.3.1 The items contained in section 5.1 shall always be included in the review of this section.
- 5.3.2 Access panels (for example, guards) for maintenance and adjustment, including discharge chute and cutter housing, shall be closed and secured prior to starting the engine of brush chippers. These access panels shall not be opened or unsecured until the engine and all moving parts have come to a complete stop (see Annex C, General Safety Procedures That Apply to All Tree Work).
- 5.3.3 Rotary drum or disc brush chippers not equipped with a mechanical infeed system shall be equipped with an infeed hopper not less than 85 inches (2.15 m) measured from the blades or knives to ground level over the center line of the hopper. Side members of the infeed hopper shall have sufficient height so as to prevent workers from contacting the blades or knives during operations.
- 5.3.4 Rotary drum or disc brush chippers not equipped with a mechanical infeed system shall have a flexible anti-kickback device installed in the infeed hopper to reduce the risk of injury from flying chips and debris.
- 5.3.5 Chippers equipped with a mechanical infeed system shall have a quick-stop and reversing device on the infeed system. The activating mechanism for the quick-stop and reversing device shall be located across the top, along each side, and close to the feed end of the infeed hopper within easy reach of the worker.
- 5.3.6 Vision, hearing, and/or other appropriate personal protective equipment shall be worn when in the immediate area of a brush chipper in accordance with section 3.4, Personal Protective Equipment.
- 5.3.7 Arborists, mechanics, and other workers shall not, under any circumstances, reach into the infeed hopper when the cutter disc, rotary drum, or feed rollers are moving.
- 5.3.8 When trailer chippers are detached from the vehicles, they shall be chocked or otherwise secured in place.
- 5.3.9 When in a towing position, chipper safety chains shall be crossed under the tongue of the chipper and properly affixed to the towing vehicle.
- 5.3.10 See section 8.6, Brush Removal and Chipping, for additional requirements.

**BRUSH REMOVAL AND CHIPPING**  
**ANSI Z133.1-2006**  
American National Standard for Arboricultural Operations  
Safety Requirements

**8.6 Brush Removal and Chipping**

- 8.6.1 Traffic control around the jobsite shall be established prior to the start of chipping operations along roads and highways (see section 3.2, Traffic Control Around the Jobsite).
- 8.6.2 Brush and logs shall not be allowed to create hazards in the work areas.
- 8.6.3 To prevent an entanglement hazard, loose clothing, climbing equipment, body belts, harnesses, lanyards, or gauntlet-type gloves (for example, long-cuffed lineman's or welder's gloves) shall not be worn while operating chippers.
- 8.6.4 Personal protective equipment shall be worn when in the immediate area of chipping operations in accordance with section 3.4, Personal Protective Equipment, of this standard.
- 8.6.5 Training shall be provided in the proper operation, feeding, starting, and shutdown procedures for the chipper being used.
- 8.6.6 Maintenance shall be performed only by those persons authorized by the employer and trained to perform such operations.
- 8.6.7 Brush and logs shall be fed into chippers, butt or cut end first, from the side of the feed table center line, and the operator shall immediately turn away from the feed table when the brush is taken into the rotor or feed rollers. Chippers should be fed from the curbside whenever practical.
- 8.6.8 The brush chipper discharge chute or cutter housing cover shall not be raised or removed while any part of the chipper is turning or moving. Chippers shall not be used unless a discharge chute of sufficient length or design is provided that prevents personal contact with the blades (see Annex C, General Safety Procedures That Apply to All Tree Work).
- 8.6.9 Foreign material, such as stones, nails, sweepings, and rakings, shall not be fed into chippers.
- 8.6.10 Small branches shall be fed into chippers with longer branches or by being pushed with a long stick.
- 8.6.11 Hands or other parts of the body shall not be placed into the infeed hopper. Leaning into or pushing material into infeed hoppers with feet is prohibited.
- 8.6.12 While material is being fed into the chipper infeed hopper chute, pinch points continually develop within the material being chipped and between the material and machine. The operator shall be aware of this situation and respond accordingly.
- 8.6.13 When feeding a chipper during roadside operations, the operator shall do so in a manner that prevents him or her from stepping into traffic or being pushed into traffic by the material that is being fed into the chipper.
- 8.6.14 When using a winch in chipper operations, the operator shall ensure that the winch cable is properly stored before initiating chipper operations.
- 8.6.15 Refer to section 5.3, Brush Chippers, for additional information.

## OPERATING INSTRUCTIONS

Count your extremities before you start!  
Feet, hands, fingers, etc.

1. Read the manual again.
2. Look at the finger decal and study it. These could be yours!
3. Cut and install PTO shaft and cover as directed in this manual.
4. **BE SURE** all guards are in place before starting machine.
5. Set feed handle in reverse position (push towards machine).
6. Set direction of discharge chute and tighten in position.
7. Be sure machine and tractor is on a dry, flat surface and it's secured from rolling.  
**HINT:** Be sure machine is not too close to the woodpile. You need room to work and move around.
8. Bring tractor up to R.P.M. to give the PTO shaft 540 R.P.M.
9. Engage feed handle. NOTE: You will notice the more you pull the handle towards the rear of the machine, the faster the roll turns and when you push in the other direction the roll slows down.
10. You are ready to chip wood, as soon as you put your safety glasses and gloves on and insert earplugs.
11. Standing at the rear of the machine, looking at the hopper, feed the wood into the feed roll. Once the machine begins, turn and walk away from the machine. It will draw the wood into without your help. Go get another piece and repeat this procedure.
12. With large diameter pieces, it may be necessary to send in a smaller piece to start the feed roll. Also, it may be necessary to monitor R.P.M. and back off on feed speed, (if you do not have the optional Speed Sensing).

## HINTS

1. When operating machine, stand off to the side of the feed hopper when feeding wood into the machine. **NEVER STAND DIRECTLY IN FRONT OF THE FEED HOPPER WHEN FEEDING WOOD INTO THE MACHINE.**
2. When using the chipper and you have a short piece of wood bouncing around and not being grabbed by the feed roll, **LEAVE IT! DO NOT TRY TO PUSH IT THROUGH WITH ARMS OR LEGS!** The next limb will push it through.
3. When through with the job let the machine clear itself completely, making sure all material is through the machine before shutting it down. This will prevent injuries from flying debris when the machine is started up at the next job.
4. **COUNT YOUR EXTREMITIES AGAIN. BE SURE THIS NUMBER MATCHES YOUR STARTING NUMBER.**

**WHILE PERFORMING MAINTENANCE OR REPAIR, ALWAYS DISCONNECT  
THE PTO SHAFT FROM THE TRACTOR!**

## SERVICE SCHEDULE

1. **Grease** all main bearings once a day. **DO NOT OVER GREASE.** Wipe extra grease off bearings. Bearings under guards for feed roll need to be greased at least once a week. When removing guards, check chain tension.
2. Be sure to **clean** entire machine after using. Should it become necessary to remove the exhaust chute, **DISCONNECT DRIVE SHAFT FROM TRACTOR. NEVER RUN UNIT WHILE EXHAUST CHUTE IS REMOVED.**
3. **Sharpen/change chipper blades: DISCONNECT DRIVE SHAFT.** Be sure to put a red lock out tag on this machine to warn others of pending danger. Remove top pin from chipper housing access door and pivot housing open. This will allow access to impeller. Rotate impeller to a comfortable working position and tighten pusher screw against the impeller. This will lock the impeller while you service the blades. Sharpen the blades as evenly as possible and be sure you Locktite (We use Locktite Blue 242 when installing blades at the factory) and tighten all bolts. A loose bolt coming out of this machine would be a large bullet. Should you drop a nut, bolt or blade in the housing **YOU MUST** retrieve it before you start up the machine. **HINT:** Salsco recommends replacing hardware when replacing or sharpening chipper blades.
4. **Bed knife adjustment** is .070. To adjust the bed knife, remove access door on side of chip chamber and rotate impeller until blades pass in front of bed knife. Check with feeler gauge and set to .070. Repeat procedure for horizontal knife.
5. **Adjust infeed roll housing:** Remove both guards and pry housing front or rear and shim behind nylon. Tighten up and remove play.
6. **Remove feed roll box:** Periodically the feed roll assembly will require disassembly. Remove the two hoses going to the drive motor (be sure to mark them for reassembly). Also, you must check the rotation of the feed roll upon reinstallation. Cap open hydraulic hoses. **Dirt is any hydraulic systems enemy.** Connect chain hoist or lifting device to feed roll box assembly and remove from machine. The feed roll can now be worked on to make necessary repairs. When replacing the feed roll box, be sure to shim behind the nylon wear strips to remove end play.

## SERVICE SCHEDULE

	AS NEEDED	DAILY	WEEKLY	MONTHLY
Check Wheel Bearings	X	-	-	X
Check Lug Nuts	X	-	-	-
Clean Machine	X	X	-	-
Grease Infeed Roll Bearing	X	-	X	-
Grease Disc Shaft Bearing	X	X	-	-
Sharpen Chipper Blades	X OR	-	X	-
Check & Adjust Bed Knife	X OR	-	X	-
Check & Adjust Roll Housing	-	-	-	X
Check Tire Air Pressure	X	-	-	X
Check all Nuts & Bolts	X	X	-	-
Check Hydraulic Hoses	X	-	-	X
Check Hydraulic Oil	X	-	-	X

**NEVER, UNDER ANY CIRCUMSTANCES, CONNECT THE PTO SHAFT TO THE TRACTOR WHEN UNIT IS OPEN OR AT ANY TIME DURING SERVICE OR ROUTINE MAINTENANCE**

## IMPELLER REMOVAL PROCEDURE.

1. Remove discharge elbow.
2. Remove pin lock and pivot top housing open.
3. Remove top housing exhaust half.
4. Remove belt guard.
5. Remove hydraulic pump. Leave hoses connected, just slide out of sleeve and lay on the side.
6. Loosen engine-mounting bolts and back off slide pusher bolts. Loosen belts and remove.
7. Remove pulley from impeller shaft.
8. Remove top and bottom clevis pins from front feed wheel lift cylinder if unit is equipped with this option.
9. Loosen horizontal and vertical bed knives and slide them away from the impeller.
10. Remove chip blades from impeller. (Follow procedure in service schedule, line item # 4)
11. Connect lifting device to impeller. (Use bolt hole for chip blade and **KEEP IN MIND** – WHEN CHOOSING A LIFTING DEVICE, THE IMPELLER WEIGHS APPROXIMATELY 700-lbs.)
12. Remove bolts from both flange bearings. Back off setscrews in bearings.
13. Carefully lift impeller out of machine.
14. Remove both flange bearings and all spacers from impeller.

## INSTALLATION OF IMPELLER

1. Connect suitable lifting device to impeller and set in machine. **KEEP IN MIND** – WHEN CHOOSING A LIFTING DEVICE, THE IMPELLER WEIGHS APPROXIMATELY 700-lbs. Be sure both shaft ends are clean and free from burrs. Bearing must slide freely on shaft.
2. Slide bearing on shafts and start the four bolts, rear bearing, two front bearings diagonally.
3. Tighten four bolts on rear bearing and two bolts on front bearings diagonally.
4. Slide impeller towards rear of machine. Impeller hub should touch rear-bearing race.
5. Measure distance from impeller hub and front bearing race.
6. Remove front bearing slide shims over shaft to equal that distance. **CAUTION: DO NOT ADD MORE SHIMS THAN ARE REQUIRED.** This could cause premature bearing failure. Reinstall front bearing.
7. With impeller shimmed and bearings tight, impeller should not slide front or rear.
8. Install all bearing mounting bolts with blue Loctite. Also Loctite and tighten bearing set screws.
9. Install all chip blades. Be sure to use new hardware and Loctite each time blades are removed and reinstalled. (Follow procedure in service schedule, line item #4)
10. Set bed knives and lock in place. (.070 clearance between chip blades and bed knives)
11. Reinstall top housing and discharge elbow. Be sure to use roll pin to keep housing aligned.
12. Install pulley. Be sure to use straight edge to line up pulley.
13. Install belts and adjust to specs shown in service manual with discharge chute and impeller assembly.
14. Be sure to recheck pulley with straight edge.
15. Install pump and use Loctite.
16. Install belt guard.
17. Install front lift cylinder, if so equipped.
18. Check to be sure all guards are in place and all bolts and nuts have been installed and tightened to proper specs.
19. Re-connect PTO Shaft & Cover to tractor.
20. Engage impeller and up to operating R.P.M. **DO NOT START UNIT WITHOUT ALL GUARDS IN PLACE.**
21. Test lift cylinder feed wheel if so equipped.
22. Lower feed wheel and disengage PTO.
23. Once machine has come to a halt, re-grease bearings.
24. Send machine to work. It's ready!

**REMEMBER: DISCONNECT PTO SHAFT AND LOCK-OUT UNIT WHENEVER PERFORMING SERVICE AND MAINTENANCE.**

ISSUED: 09-09-2009

ITEM	DESCRIPTION	PART NO	QTY
	810 PTO CHIPPER ASSY	0010095	

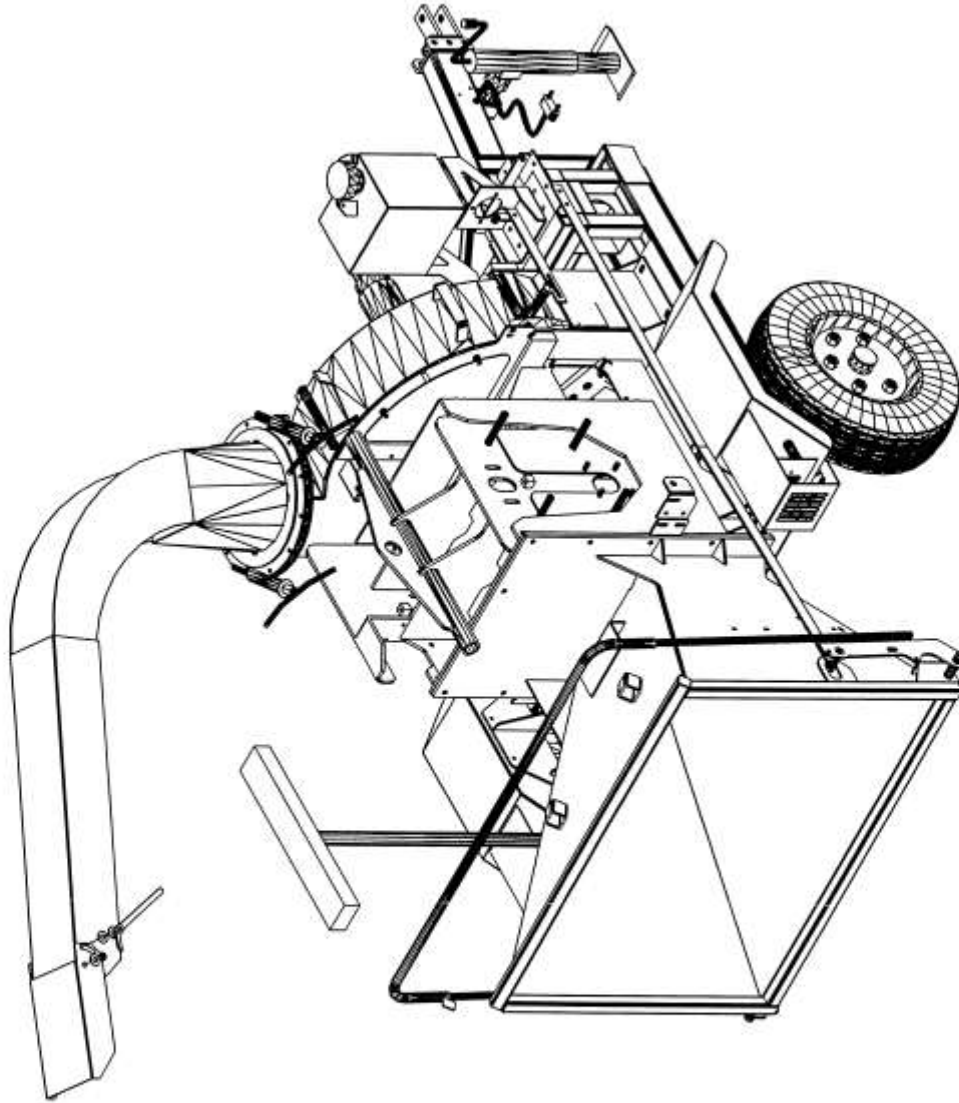

810 PTO CHIPPER - DWG #1

ISSUED: 09-09-2009

ITEM	DESCRIPTION	PART NO	QTY
1	TOWFRAME, BASE	0219287	1
2	HOUSING, IMPELLER - LOWER	0228276	1
3	CONNECTOR, 7 POLE PLUG	0315065	1
4	HITCH, (TRACTOR)	0225032	1
5	JACK 10" TRAVEL, PIPE MOUNT - SWIVEL SIDE	0369006	1
6	SAFETY CHAIN	0309056	2
7	SAFETY HOOK	0309057	2
8	DOOR, BED KNIFE ACCESS	0260088	1
9	BLADE, VERTICAL BED KNIFE	0405156	1
10	BLADE, HORIZONTAL BED KNIFE	0405157	1
11	ADJUSTER, BLADE VERTICAL	0201025	1

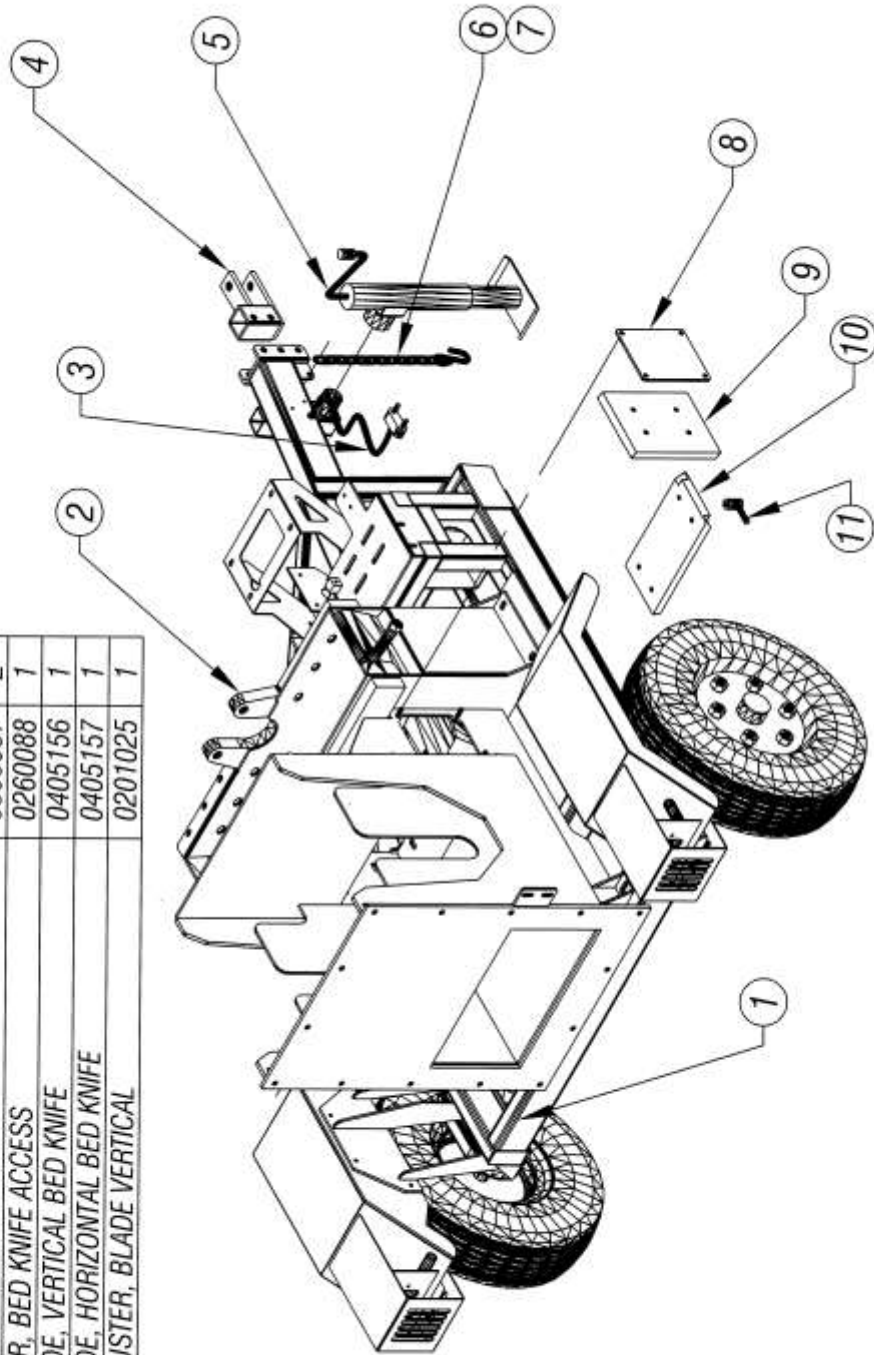

810 PTO CHIPPER - DWG #2

ITEM	DESCRIPTION	PART NO	QTY
1	CHUTE, IN-FEED	0226179	1
2	HANDLE, FORWARD/REVERSE POWER FEED	0223037	1
3	TANK, OIL - 3.5 GAL.	0252012	1
4	CAP, OIL FILL LOCKING	0271024	1
5	CAP, OIL FILL	0371061	1
6	LEVER, HYDRAULIC PUMP	0233147	1
7	ROD, HYDRAULIC PUMP - FRONT	0225032	1
8	ROD, HYDRAULIC PUMP - REAR	0369006	1
9	GUIDE, HYDRAULIC PUMP ROD	0222134	1

ISSUED: 11-02-2009

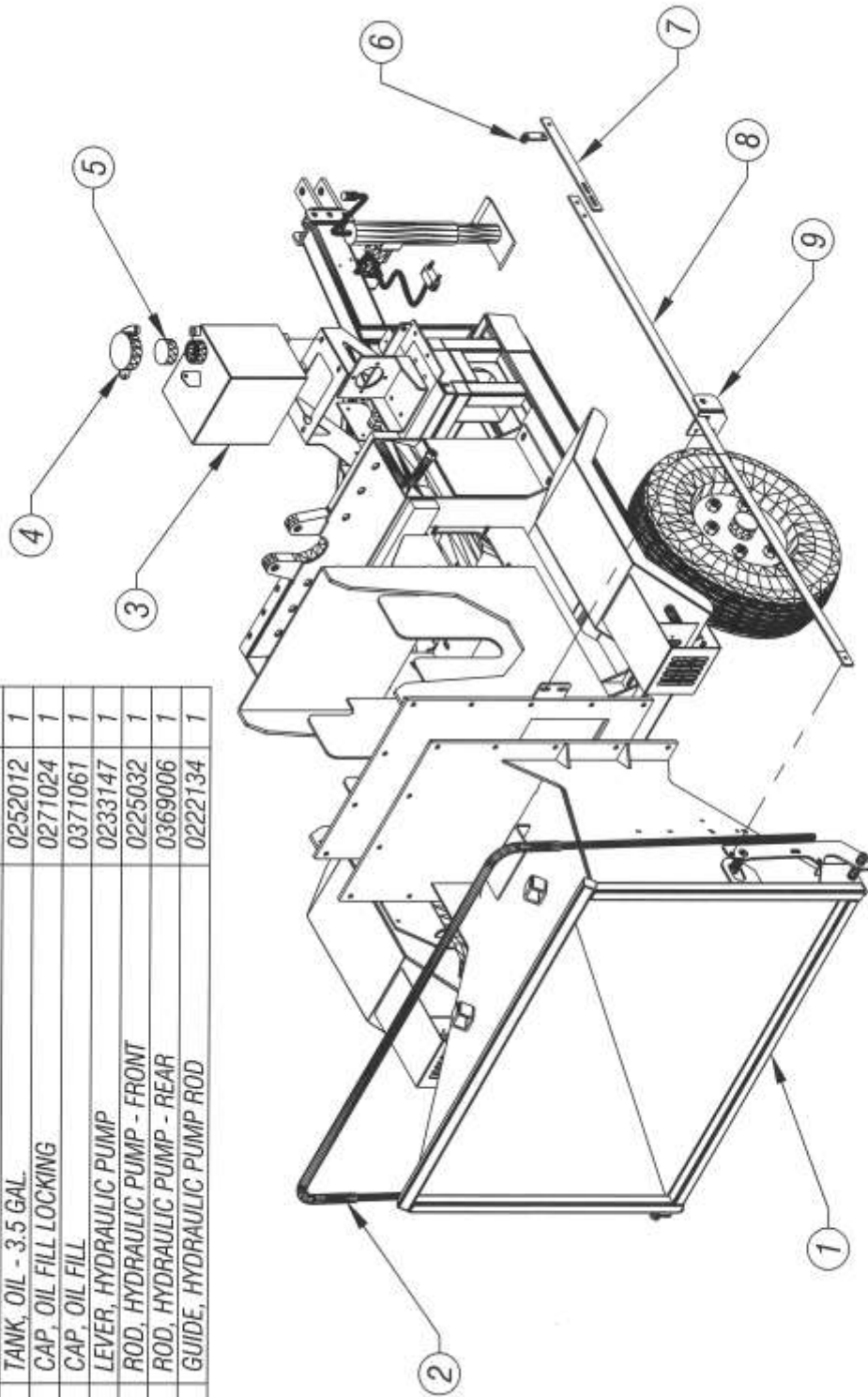

810 PTO CHIPPER - DWG #3

ISSUED: 09-09-2009

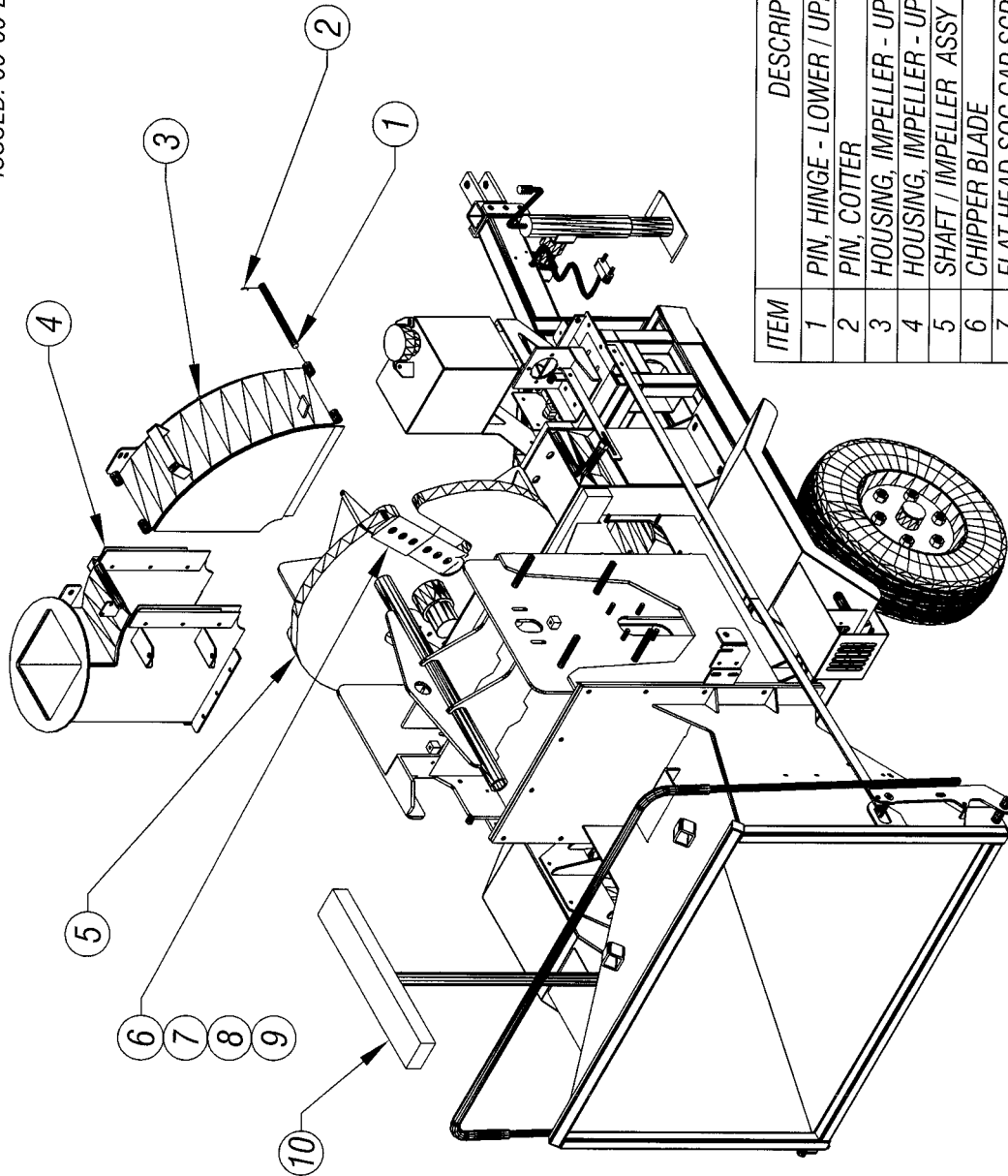

ITEM	DESCRIPTION	PART NO	QTY
1	PIN, HINGE - LOWER / UPPER HOUSING	0440034	1
2	PIN, COTTER	0340004	2
3	HOUSING, IMPELLER - UPPER REMOVABLE	0228219	1
4	HOUSING, IMPELLER - UPPER FIXED	0228218	1
5	SHAFT / IMPELLER ASSY	0248168	1
6	CHIPPER BLADE	0305047	4
7	FLAT HEAD SOC CAP SCREW	0346491	12
8	LOCK WASHER - SPLIT (GRADE 8)	0353017	12
9	NUT, HEX LOCK - STOVER	0338154	12
10	WOOD PUSHER ROD	0359007	1

810 PTO CHIPPER - DWG #4

ISSUED: 09-09-2009

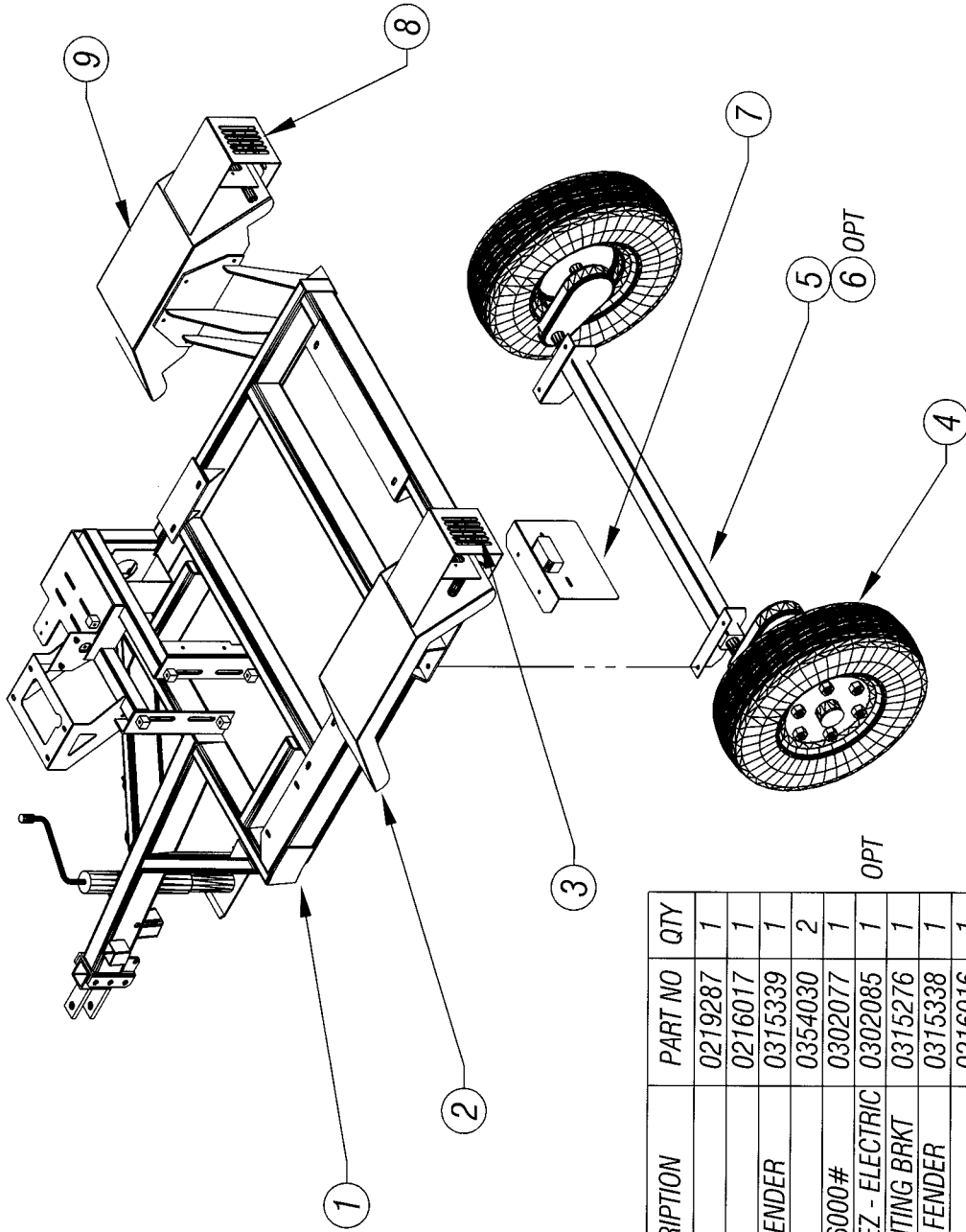

ITEM	DESCRIPTION	PART NO	QTY
1	TOWFRAME, BASE	0219287	1
2	FENDER - LEFT	0216017	1
3	TRAILER LIGHT - LEFT FENDER	0315339	1
4	TIRE / WHEEL ASSY	0354030	2
5	AXLE, #11 TORFLEX - 6000#	0302077	1
6	AXLE, #11 TORFLEX - EZ - ELECTRIC	0302085	1
7	LICENSE LIGHT / MOUNTING BRKT	0315276	1
8	TRAILER LIGHT - RIGHT FENDER	0315338	1
9	FENDER - RIGHT	0216016	1

OPT

810 PTO CHIPPER - DWG #5



ISSUED: 09-09-2009

ITEM	DESCRIPTION	PART NO	QTY
1	SHAFT / IMPELLER	0248168	1
2	SHEAVE, 5V-SECTION (7.5" OD) IMP. SIDE	0342132	1
3	SF-BUSHING (2 3/4" ID)	0342133	1
4	V-BELT, 5V STYLE	0303080	5
5	SHEAVE, 5V-SECTION (15" OD) PTO SIDE	0342134	1
6	E-BUSHING (1.5" ID)	0342135	1
7	BEARING, PILLOW BLOCK (1.5" ID)	0303057	2
8	SHAFT, PTO INPUT	0348192	1
9	HYDRAULIC PUMP	0330021	1
10	BRACKET, HYDRAULIC PUMP MOUNTING	0406802	1
11	SHEAVE, SINGLE GROOVE V-BELT (3.9" OD)	0342136	1
12	L-BUSHING (15mm ID)	0342067	1
13	V-BELT (50")	0304102	1

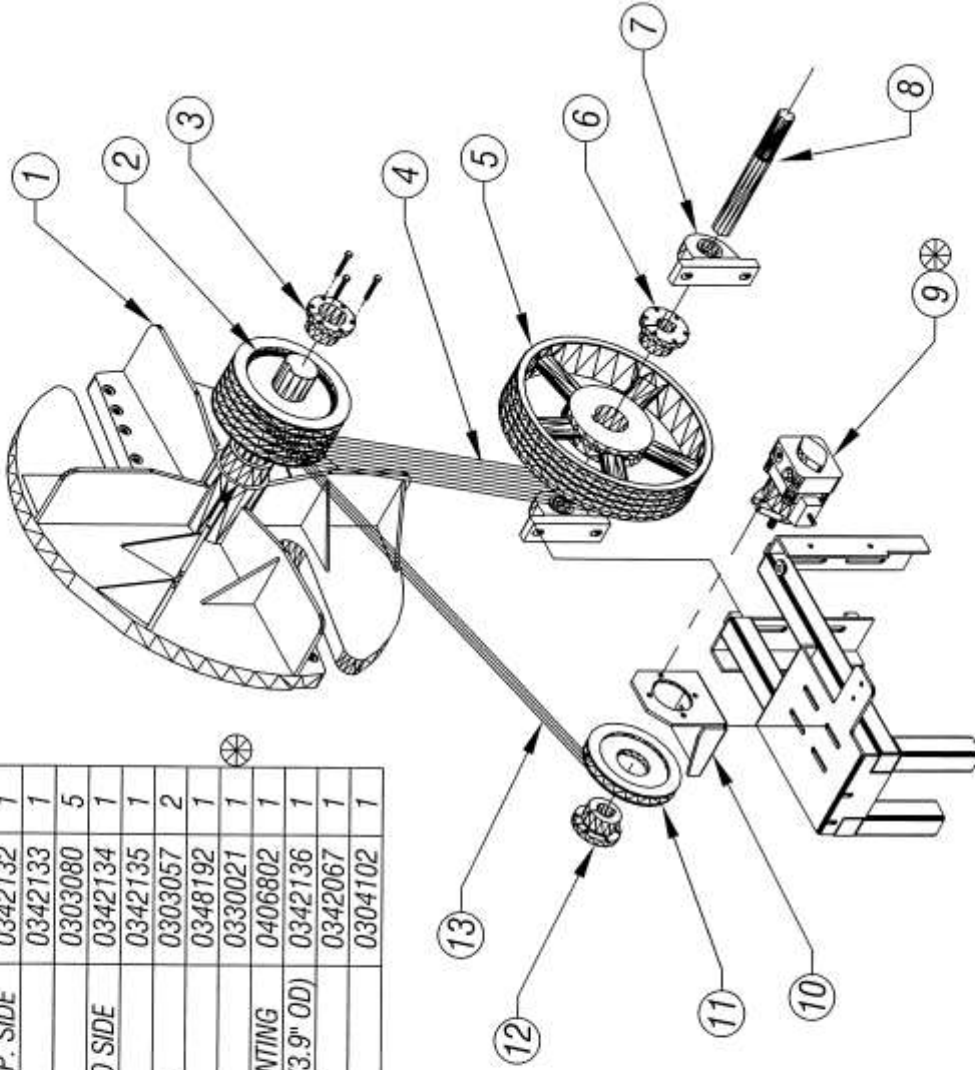

NOTE:  
 USED WITHOUT HYD LIFT OPTION  
 PUMP IS USED AS DIRECTIONAL VALVE

810 PTO CHIPPER - DWG #7

ISSUED: 09-09-2009

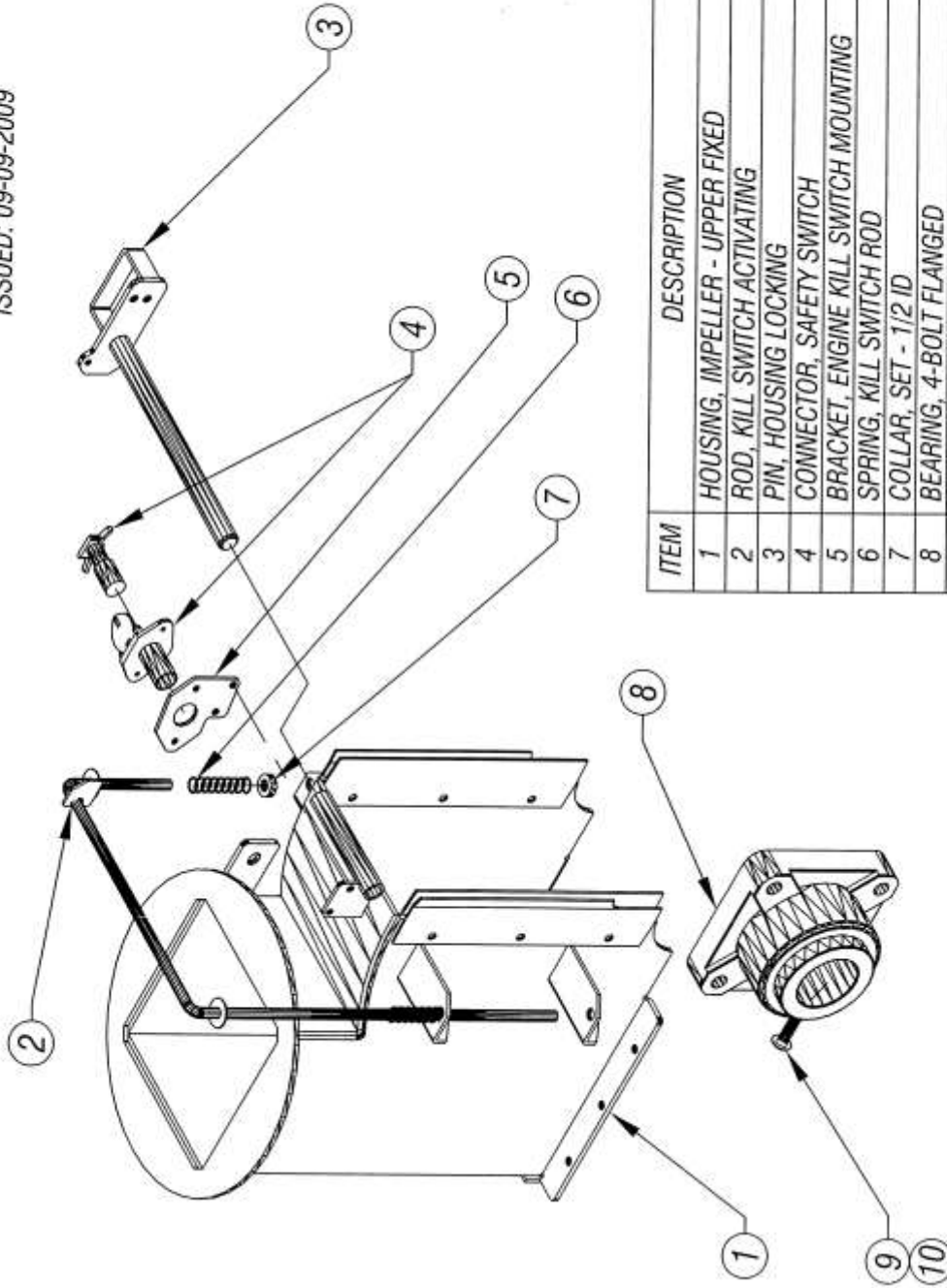

ITEM	DESCRIPTION	PART NO	QTY
1	HOUSING, IMPELLER - UPPER FIXED	0228218	1
2	ROD, KILL SWITCH ACTIVATING	0245131	1
3	PIN, HOUSING LOCKING	0240096	1
4	CONNECTOR, SAFETY SWITCH	0315242	1
5	BRACKET, ENGINE KILL SWITCH MOUNTING	0406577	1
6	SPRING, KILL SWITCH ROD	0350030	2
7	COLLAR, SET - 1/2 ID	0311005	1
8	BEARING, 4-BOLT FLANGED	0303035	2
9	SOC HD CAP SCREW, 1/2-20 X 1 3/4	0346442	1
10	JAM NUT, 1/2-20	0338058	1

810 PTO CHIPPER - DWG #8

ISSUED: 09-09-2009

ITEM	DESCRIPTION	PART NO	QTY
1	GUARD, BELT	0221335	1
2	GUARD, HYDRAULIC PUMP	0221336	1
3	GUARD, DRIVE FEED WHEEL CHAIN	0221096	1
4	GUARD, IDLER FEED WHEEL CHAIN	0221097	1

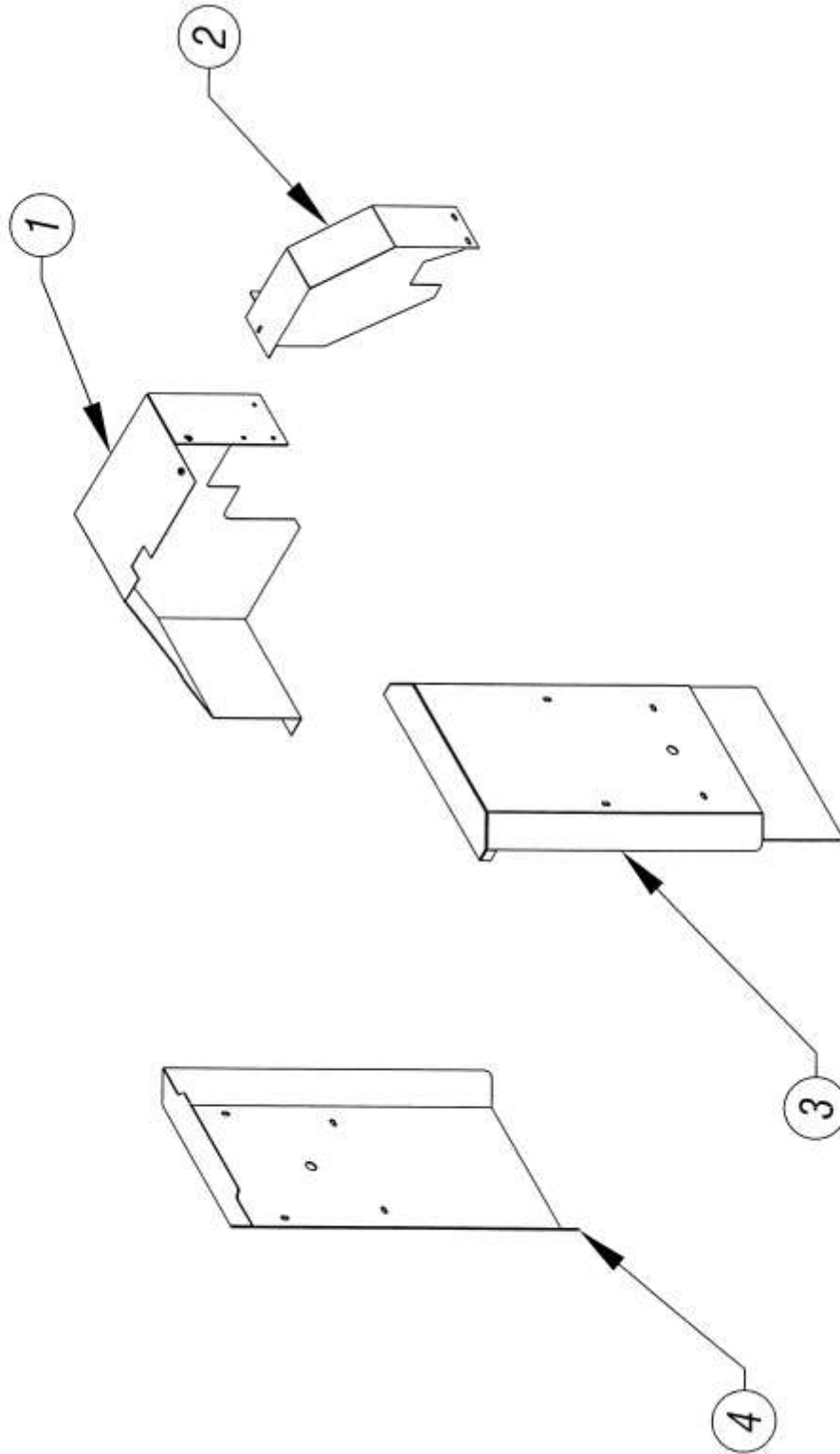

810 PTO CHIPPER - DWG #9

ISSUED: 09-09-2009

ITEM	DESCRIPTION	PART NO	QTY
1	CHUTE, DISCHARGE	0226135	1
2	WING NUT	0238500	1
3	LOCK WASHER, SPLIT	0353005	1
4	BOLT, CARRIAGE	0346429	4
5	FLAT WASHER	0353104	4
6	NUT, NYLON LOCK	0338104	3
7	CHUTE, DEFLECTOR	0426028	1
8	CLAMP, REAR HALF	0210120	1
9	WING NUT, 3/4-10	0238501	2
10	CLAMP, FRONT HALF	0210067	1
11	CLAMP STRIP, - 1/8 x 3/8 x 14"	0356045	1

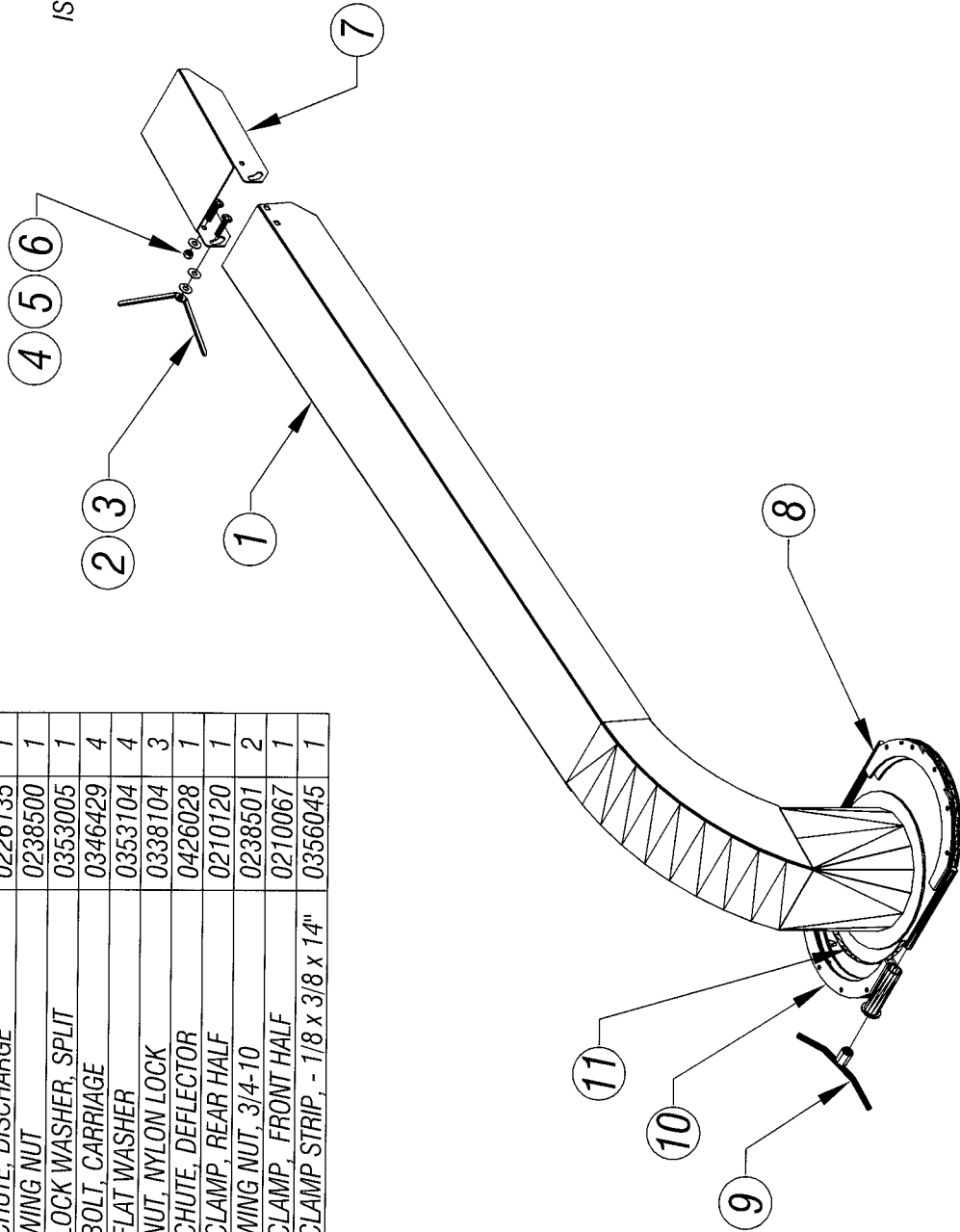

810 PTO CHIPPER - DWG #10

ISSUED: 09-09-2009

ITEM	DESCRIPTION	PART NO	QTY
1	AXLE, #11 TORFLEX-EZ-ELECTRIC - 6000LBS	0302085	1
2	LINK, VALVE ACTUATOR	0234066	1
3	ADJUSTER, VALVE	0201038	1
4	VALVE, DIRECTIONAL	0330165	1
5	JACK 15" TRAVEL, PIPE MOUNT - SWIVEL SIDE	0369005	1

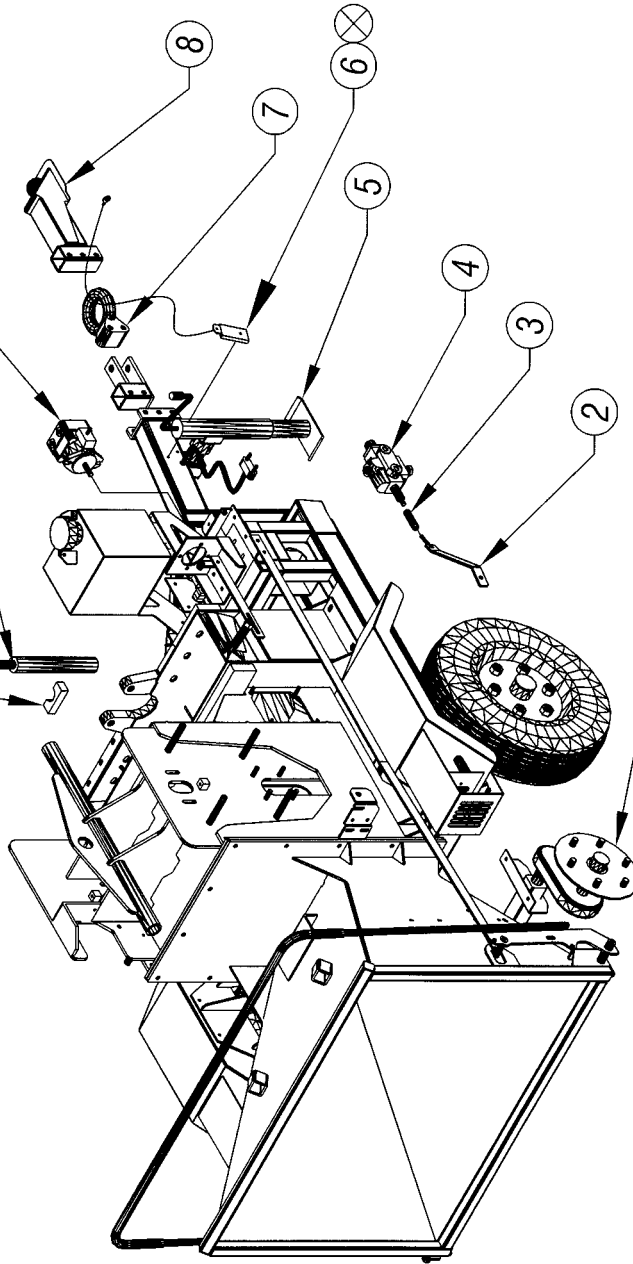

NOTE :

⊗ THIS HYD PUMP IS USED WITH HYDRAULIC LIFT OPTION

⊗ BREAK-A-WAY SWITCH IS USED WITH ITEM #1 OPTION ONLY

6	BREAK-A-WAY SWITCH	0302030	1
7	3" PINTLE RING	0325014	1
8	TONGUE COUPLER - 2 5/16"	0225029	1
9	PUMP, HYD (RIGHT HAND ROTATION)	0330104	1
10	CYLINDER, HYD 1.5" BORE 10" STROKE 3/4" ROD	0330153	2
11	PAD, CYLINDER ROD END	0439202	2
12	CLAMP, WELD MOUNT TUBE 2" OD	0330164	2

OPTIONAL ITEMS AVAILABLE WITH THIS CHIPPER  
810 PTO CHIPPER - DWG #11

ISSUED: 09-09-2009

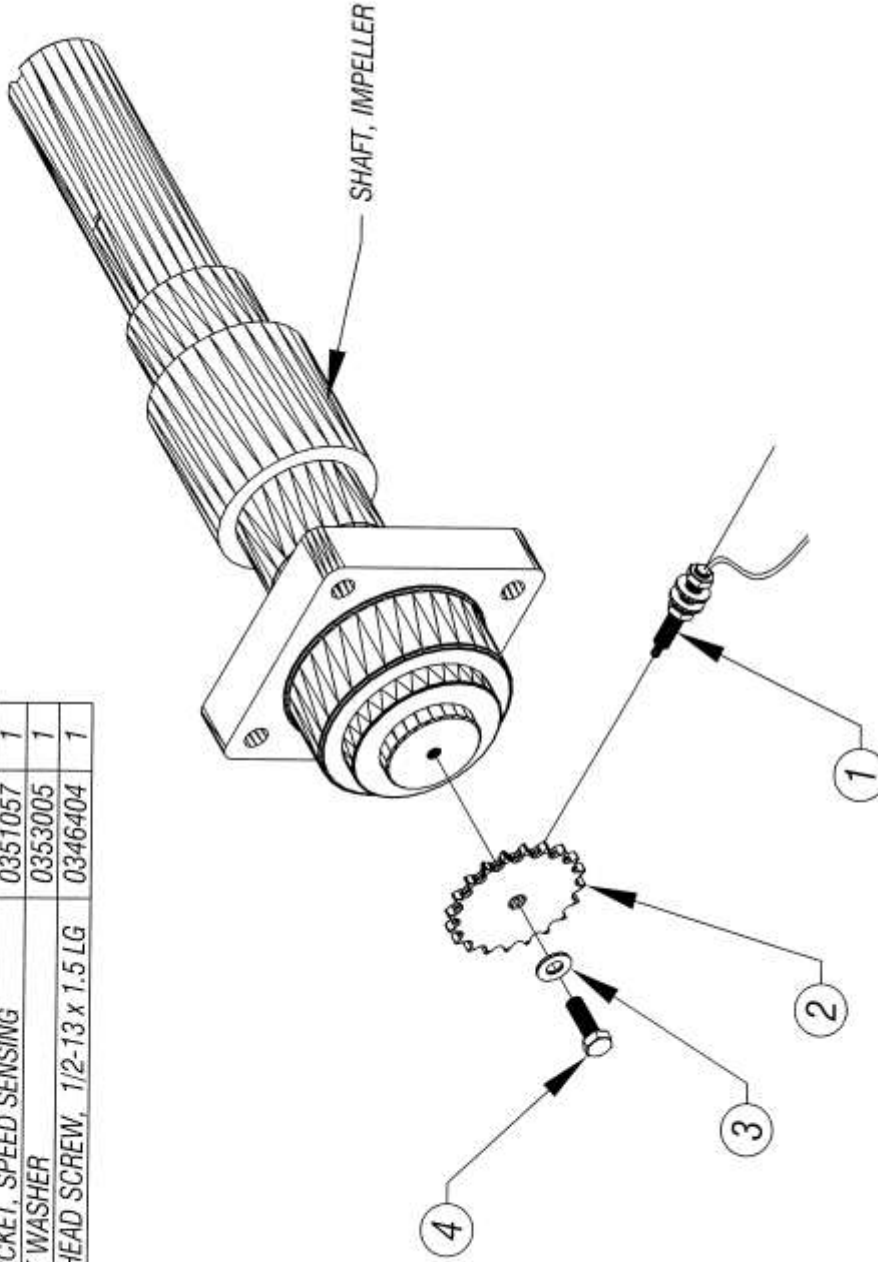

ITEM	DESCRIPTION	PART NO	QTY
1	MAGNETIC PICK-UP	0315128	1
2	SPROCKET, SPEED SENSING	0351057	1
3	LOCK WASHER	0353005	1
4	HEX HEAD SCREW, 1/2-13 x 1.5 LG	0346404	1

OPTIONAL ITEMS AVAILABLE WITH THIS CHIPPER  
810 PTO CHIPPER - DWG #12

ISSUED: 09-09-2009

ITEM	DESCRIPTION	PART NO	QTY
1	TACHOMETER WITH WIRING HARNESS	0315250	1
2	MAGNETIC PICK-UP	0315128	1
3	SOLENOID VALVE, NORMALLY OPEN	0330080	1
4	SOLENOID VALVE, NORMALLY CLOSED	0330081	1

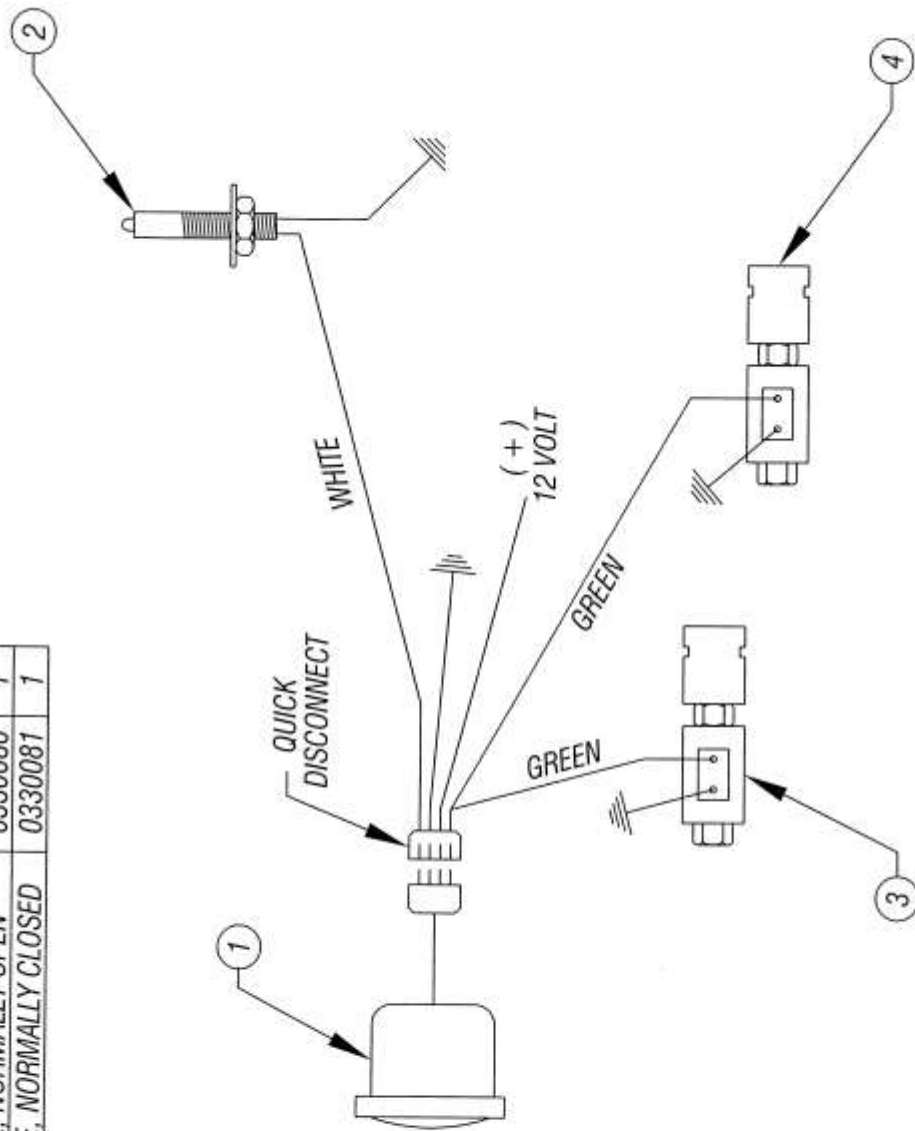

WIRING DAIGRAM FOR SPEED SENSING OPTION  
810PTO CHIPPER - DWG #13

ISSUED: 09-09-2009

# HYDRAULIC COMPONENTS

ITEM	DESCRIPTION	PART NO	QTY
1	TANK, HYDRAULIC OIL	0252012	1
2	FILTER & HOUSING	0318022	1
3	PUMP, HYDRAULIC	0330021	1
4	DRIVE MOTOR, HYDRAULIC	0330142	1

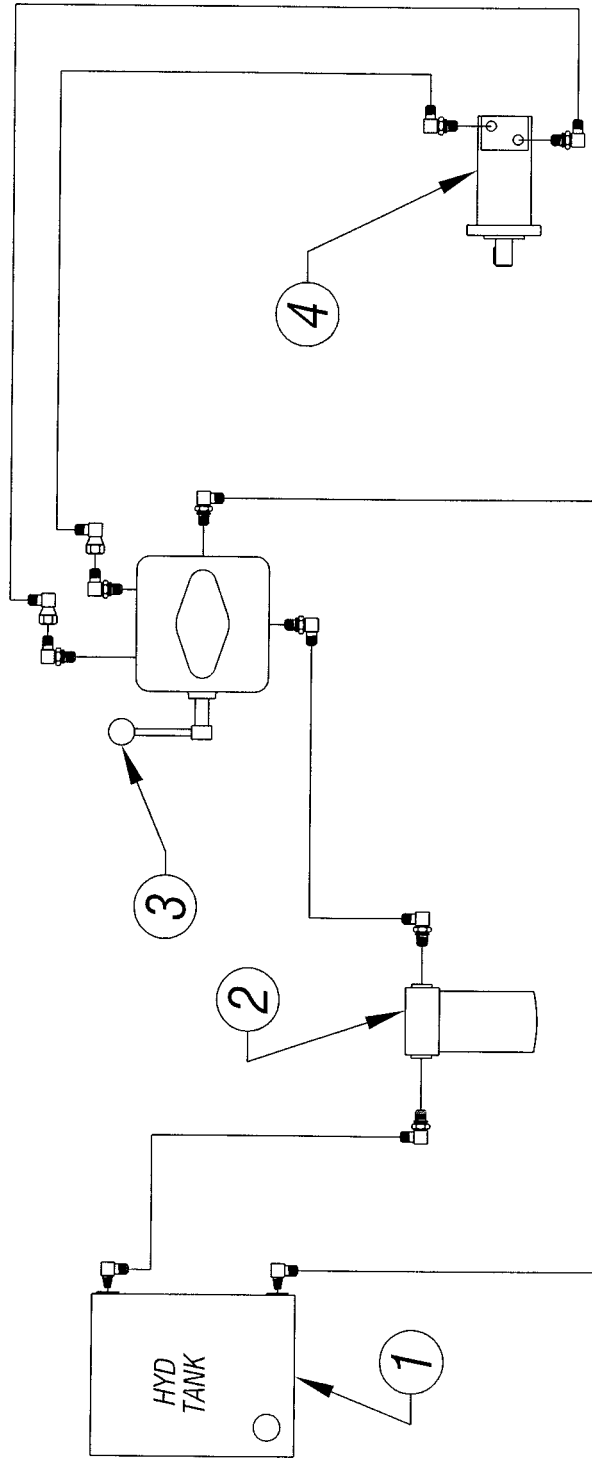

HYDRAULIC HOOK-UP, BASIC CHIPPER  
810 PTO CHIPPER - DWG #14

ISSUED: 09-09-2009

# HYDRAULIC FITTINGS

ITEM	DESCRIPTION	PART NO	QTY
1	90° ELBOW, 1/2 FLARE x 1/2 MPT	0317052	2
2	90° ELBOW, 1/2 FLARE x 3/4 O-RING	0317079	2
3	90° ELBOW, 1/2 FLARE x 3/8 O-RING	0317064	2
4	90° ELBOW, 1/2 FLARE x 1/2 O-RING	0317030	2
5	90° SWIVEL ELBOW, 1/2 FL x 1/2 O-RING	0317055	2
6	90° ELBOW, 1/2 FLARE x 5/8 O-RING	0317027	2

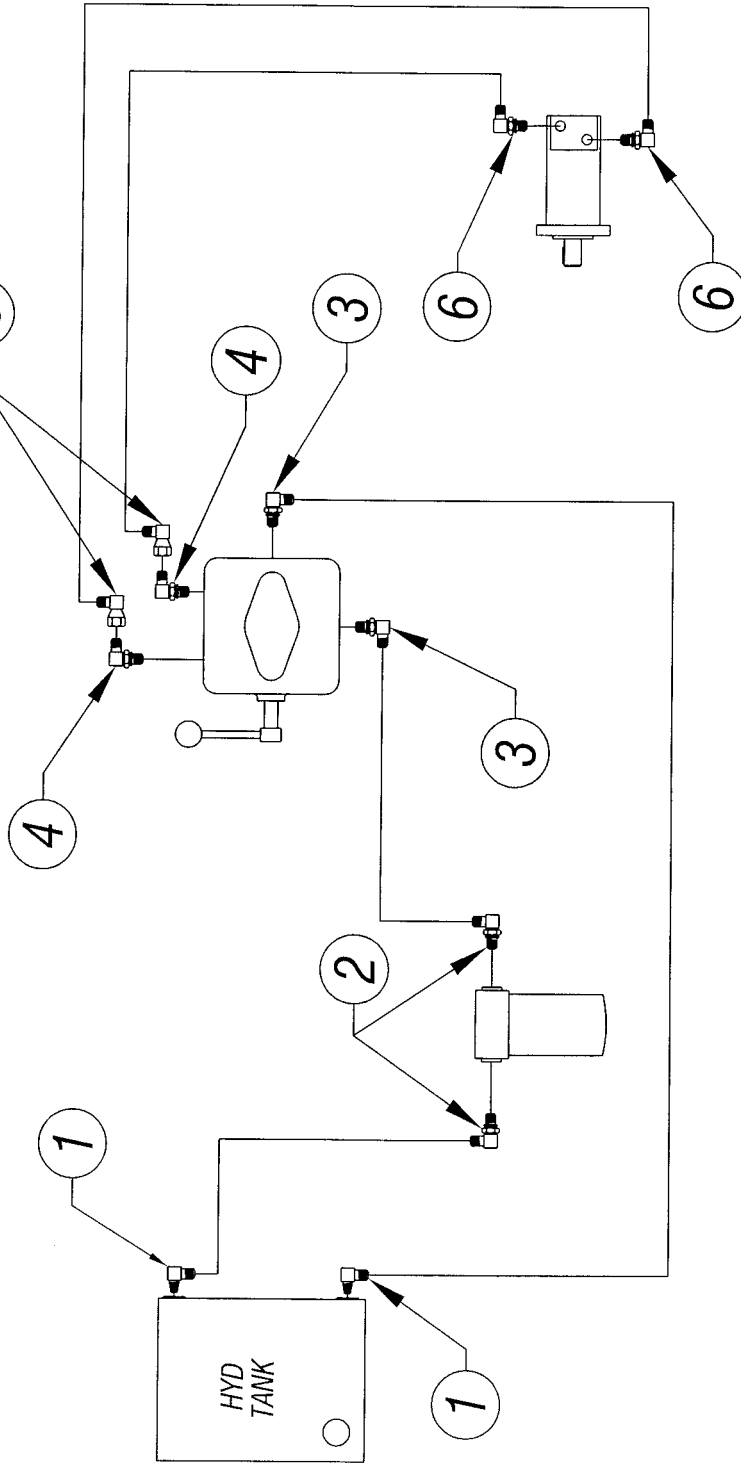

HYDRAULIC HOOK-UP, BASIC CHIPPER  
810 PTO CHIPPER - DWG #15

ISSUED: 09-09-2009

# HYDRAULIC HOSES

ITEM	DESCRIPTION	PART NO	QTY
1	HOSE, TANK TO PUMP, 1/2 ID x 38" LG	0327159	1
2	HOSE, PUMP TO MOTOR, 1/2 ID x 86" LG	0327246	1
3	HOSE, MOTOR TO PUMP, 1/2 ID x 88" LG	0327245	1
4	HOSE, PUMP TO FILTER, 1/2 ID x 21" LG	0327209	1
5	HOSE, FILTER TO TANK, 1/2 ID x 25" LG	0327160	1

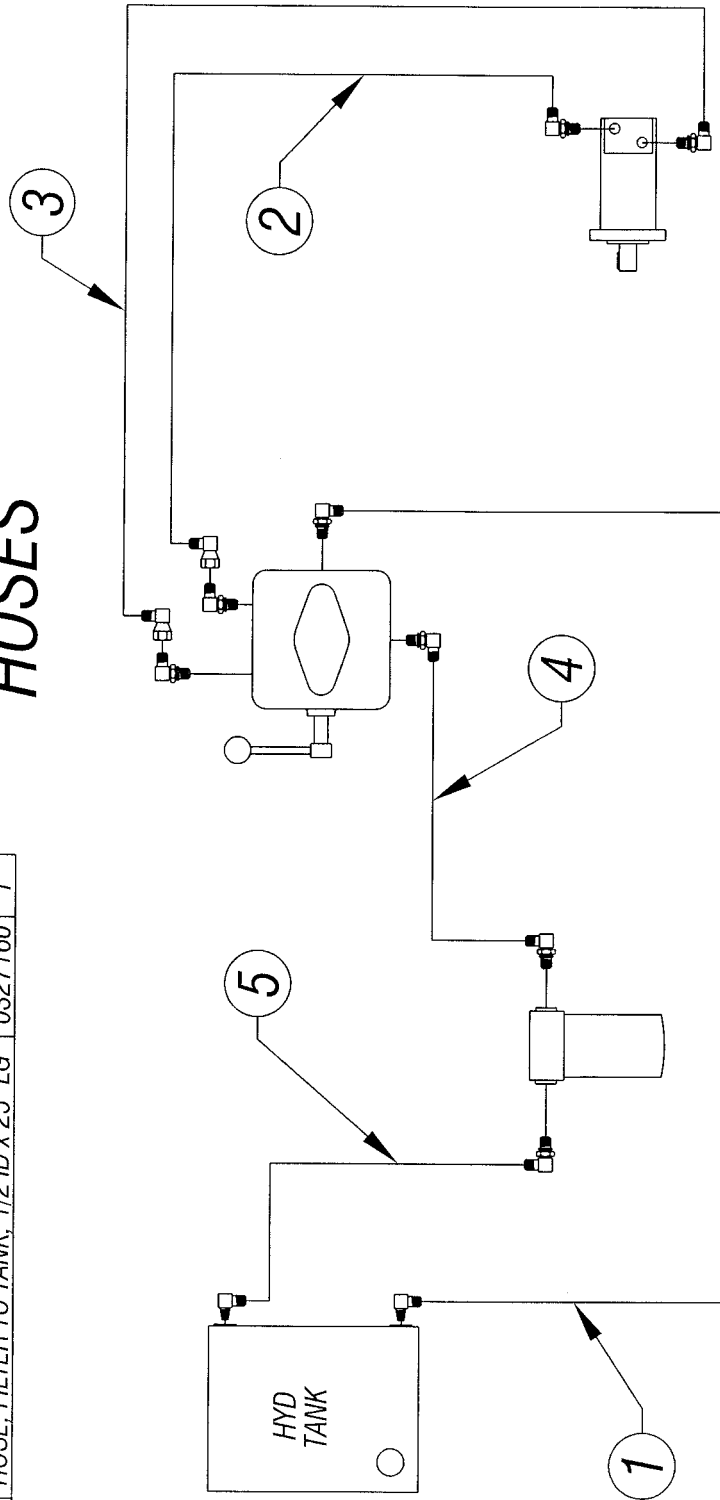

HYDRAULIC HOOK-UP, BASIC CHIPPER  
810 PTO CHIPPER - DWG #16

ISSUED:09-09-2009

# HYDRAULIC COMPONENTS

ITEM	DESCRIPTION	PART NO	QTY
1	TANK, HYDRAULIC OIL	0252012	1
2	FILTER & HOUSING	0318022	1
3	PUMP, HYDRAULIC	0330021	1
4	DRIVE MOTOR, HYDRAULIC	0330142	1
5	VALVE, SOLENOID- NORM. OPEN	0330106	1
6	VALVE, SOLENOID- NORM. CLOSED	0330081	1

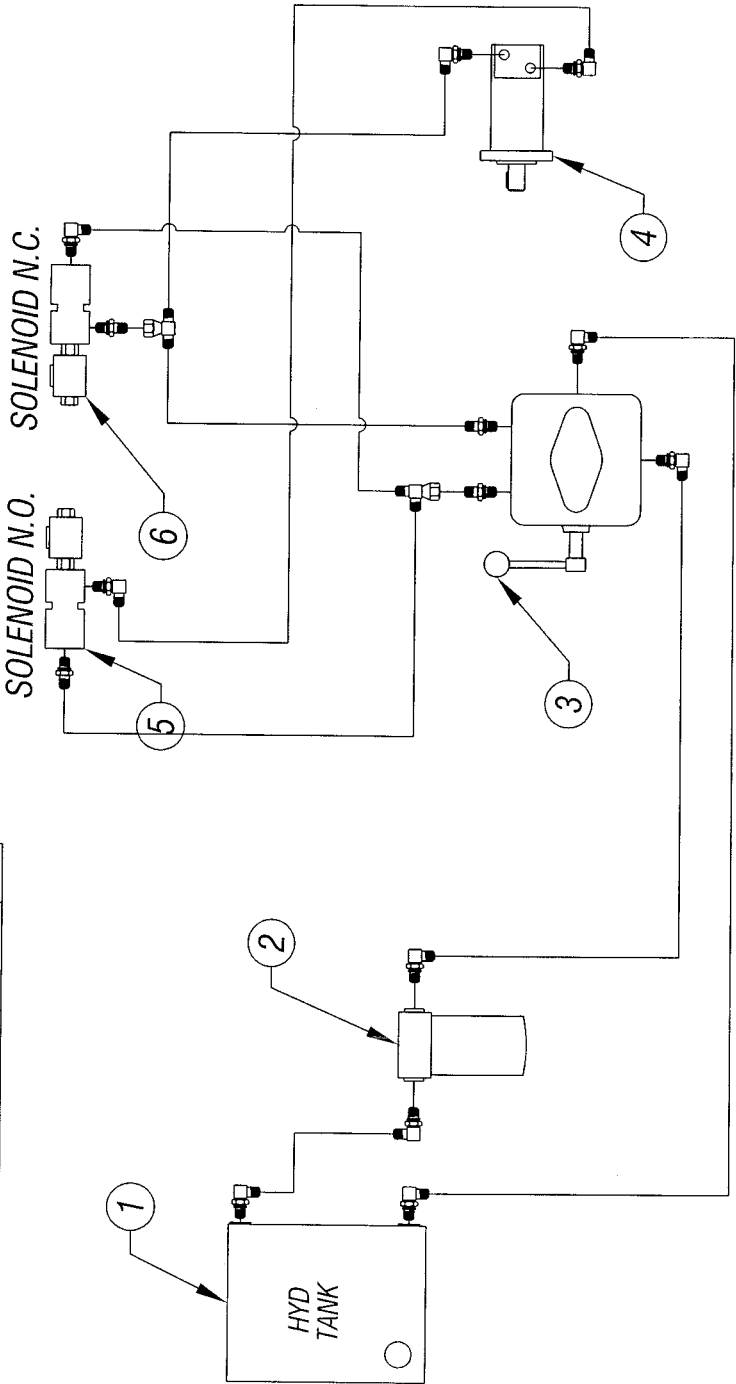

HYDRAULIC HOOK-UP, BASIC WITH SPEED SENSING  
810 PTO CHIPPER - DWG #17

ISSUED: 09-09-2009

# HYDRAULIC FITTINGS

ITEM	DESCRIPTION	PART NO	QTY
1	90° ELBOW, 1/2 FLARE x 1/2 MPT	0317052	2
2	90° ELBOW, 1/2 FLARE x 3/4 O-RING	0317079	2
3	90° ELBOW, 1/2 FLARE x 3/8 O-RING	0317064	3
4	CONNECTOR, 1/2 FLARE x 3/8 O-RING	0317066	2
5	SWIVEL RUN TEE, 1/2 FLAREx1/2 SWIV.	0317118	1
6	CONNECTOR, 1/2 FLARE x 3/8 O-RING	0317066	1
7	SWIVEL TEE, 1/2 FLRx1/2FLRx1/2 SWIV.	0317171	1
8	90° ELBOW, 1/2 FLARE x 1/2 O-RING	0317007	1
9	90° ELBOW, 1/2 FLARE x 5/8 O-RING	0317008	2

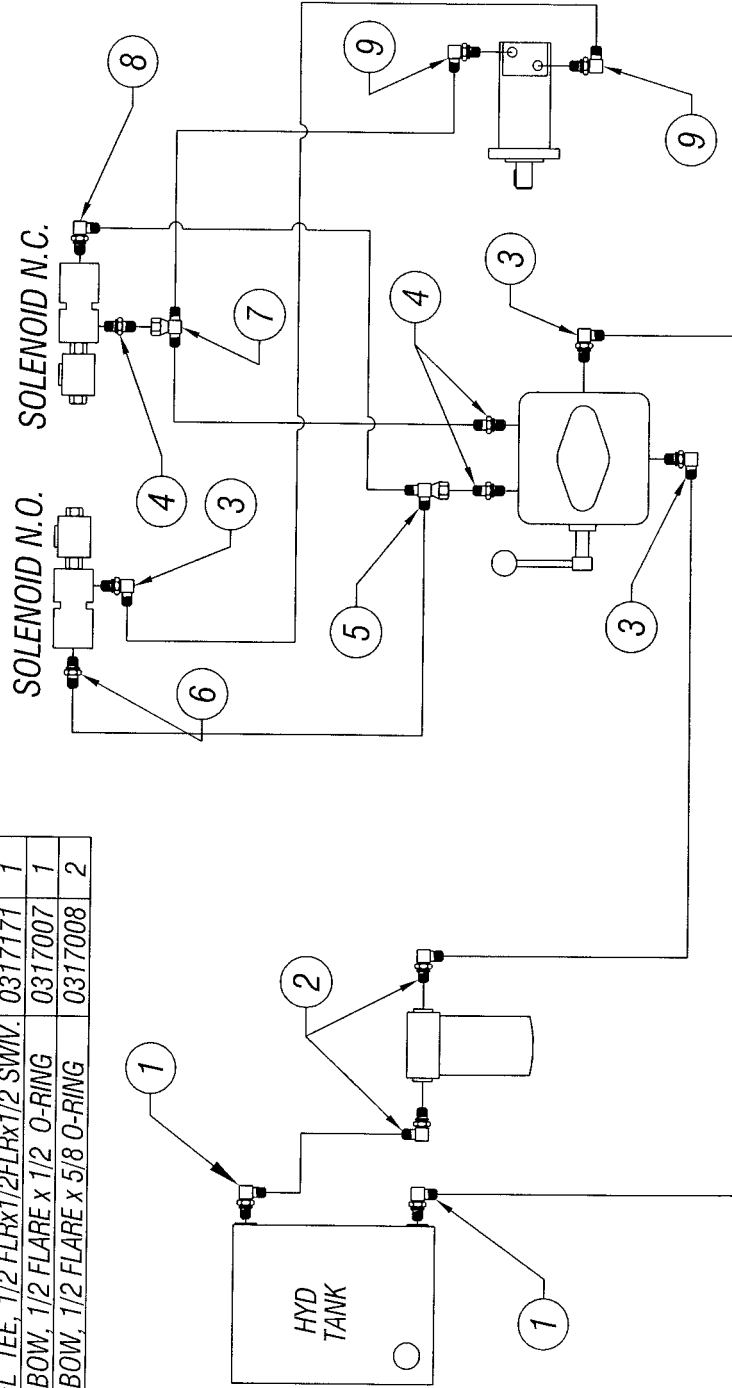

HYDRAULIC HOOK-UP, BASIC WITH SPEED SENSING  
810 PTO CHIPPER - DWG #18

ISSUED: 09-09-2009

# HYDRAULIC HOSES

ITEM	DESCRIPTION	PART NO	QTY
1	OIL TANK TO PUMP, 1/2 ID x 38" LONG	0327159	1
2	PUMP TEE TO SOL.N/C, 1/2 IDx17"LONG	0327173	1
3	PUMP TEE TO SOL.N/O, 1/2 ID x 13.5 LG	0327139	1
4	PUMP TO TEE SOL.N/C, 1/2 ID x 14.5 LG	0327161	1
5	MOTOR TO TEE SOL.N/C, 1/2 ID x 81" LG	0327247	1
6	MOTOR TO SOL.N/O, 1/2 ID x 79" LONG	0327343	1
7	PUMP TO FILTER, 1/2 ID x 21" LONG	0327209	1
8	FILTER TO HYD OIL TANK, 1/2 ID x 25"LG	0327160	1

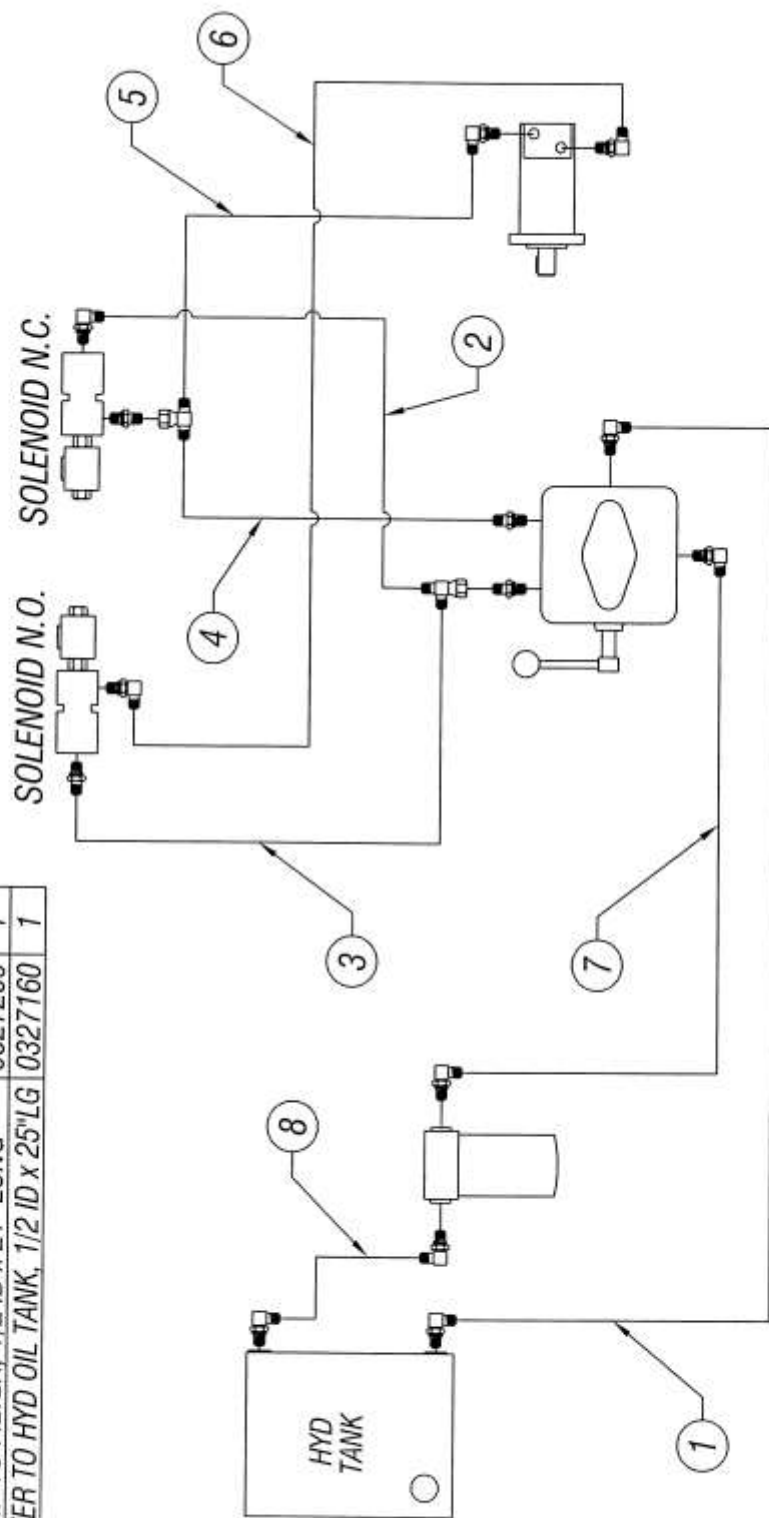

HYDRAULIC HOOK-UP, BASIC WITH SPEED SENSING  
810 PTO CHIPPER - DWG #19

ITEM	DESCRIPTION	PART NO	QTY
1	TANK, HYDRAULIC OIL	0252012	1
2	FILTER & HOUSING	0318022	1
3	HYDRAULIC PUMP	0330104	1
4	DRIVE MOTOR, HYDRAULIC	0330142	1
5	VALVE, DIRECTIONAL	0330165	1
6	CYLINDER, HYDRAULIC, LIFT	0330153	2
7	CLAMP, CYLINDER MOUNT	0330164	2
8	PAD, CYLINDER ROD END	0239780	2

ISSUED: 09-09-2009

# HYDRAULIC COMPONENTS

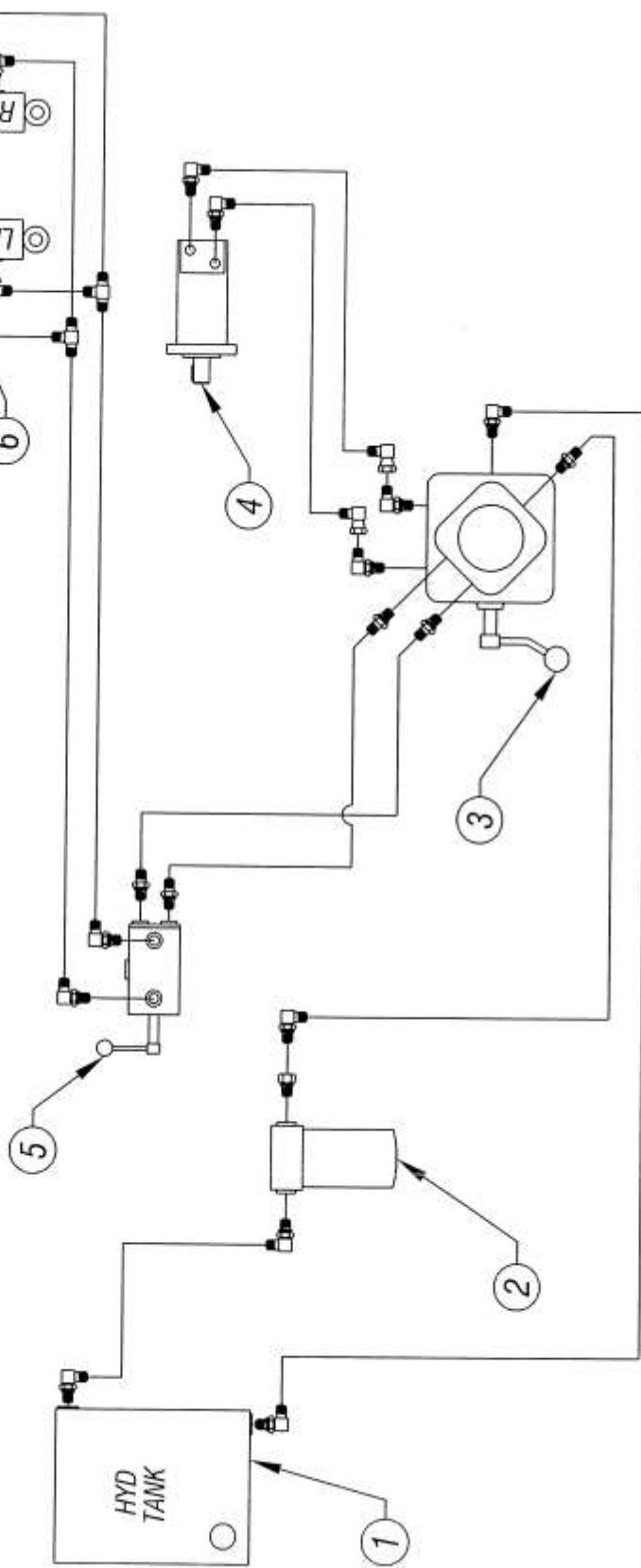

HYDRAULIC HOOK-UP, BASIC WITH SPEED SENSING & HYDRAULIC LIFT  
810 PTO CHIPPER - DWG #20

ISSUED: 09-09-2009

# HYDRAULIC FITTINGS

ITEM	DESCRIPTION	PART NO	QTY
1	90° ELBOW, 1/2 FLARE x 1/2 MPT	0317052	2
2	90° ELBOW, 1/2 FLARE x 1/2 O-RING	0317079	1
3	ADAPTER, 1/2 M- O-RINGx1/2F- O-RING	0317253	1
4	90° ELBOW, 3/8 FLARE x 1/2 O-RING	0317044	1
5	CONNECTOR, 1/2 FLARE x 1/2 O-RING	0317030	2
6	90° ELBOW, 3/8 FLARE x 3/8 O-RING	0317029	2
7	TEE, 3/8 FLARE x 3/8 FLARE x 3/8 FLARE	0317119	2
8	90° ELBOW, 3/8 FLARE x 1/4 MPT	0317046	4
9	90° ELBOW, 1/2 FLARE x 5/8 O-RING	0317008	2
10	SWIVEL ELBOW, 1/2 FLAREx1/2 FEM.SW	0317055	2
11	90° ELBOW, 1/2 FLARE x 3/8 O-RING	0317064	3
12	CONNECTOR, 3/8 FLARE x 1/4 O-RING	0317002	3

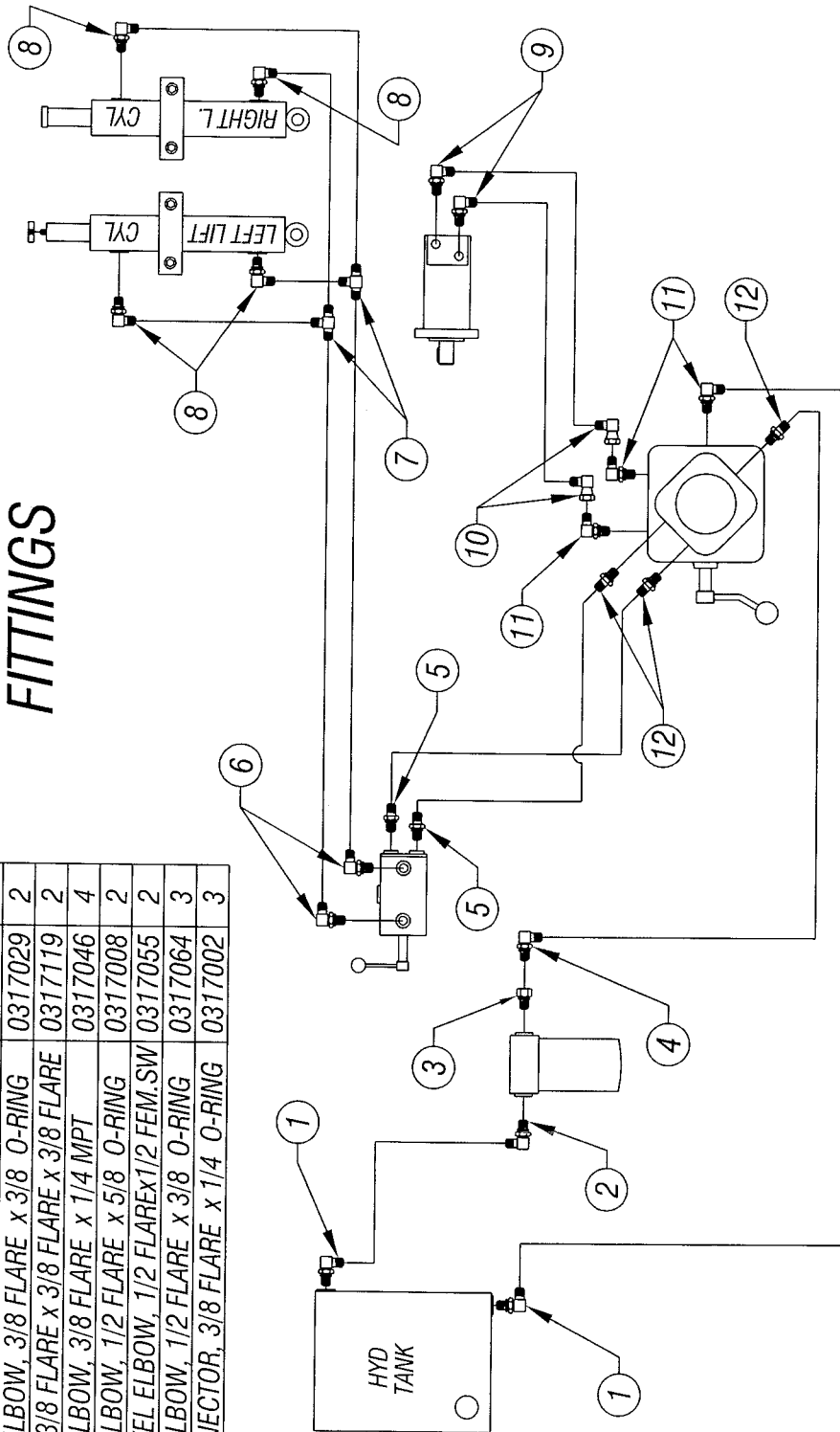

HYDRAULIC HOOK-UP, BASIC WITH SPEED SENSING & HYDRAULIC LIFT  
810 PTO CHIPPER - DWG #21

ISSUED: 09-09-2009

# HYDRAULIC HOSES

ITEM	DESCRIPTION	PART NO	QTY
1	TANK TO PUMP, 1/2 ID x 38" LONG	0327159	1
2	PUMP TO MOTOR, 1/2 ID x 88" LONG	0327245	1
3	MOTOR TO PUMP, 1/2 ID x 86" LONG	0327246	1
4	PUMP TO LIFT VALVE 3/8 ID x 98" LG	0327166	1
5	LIFT VALVE TO PUMP, 3/8 ID x 99" LG	0327167	1
6	LIFT VALVE TO TEE, 3/8 ID x 39" LONG	0327169	1
7	TEE TO LEFT CYL. 3/8 ID x 38" LONG	0327107	1
8	TEE TO LEFT CYL. 3/8 ID x 33" LONG	0327170	1
9	TEE TO RIGHT CYL. 3/8 ID x 62" LONG	0327171	1
10	TEE TO RIGHT CYL. 3/8 ID x 58" LONG	0327172	1
11	LIFT VALVE TO TEE, 3/8 ID x 37" LG	0327168	1
12	PUMP TO FILTER, 3/8 ID x 27" LONG	0327342	1
13	FILTER TO HYD TANK, 1/2 ID x 25" LG	0327160	1

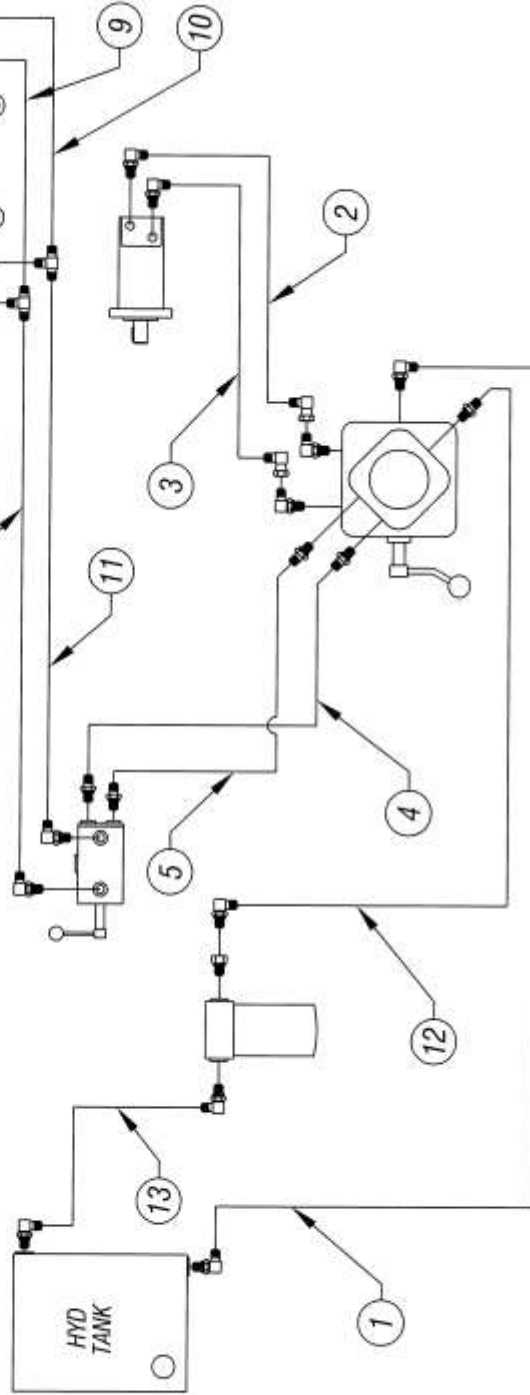

HYDRAULIC HOOK-UP, BASIC WITH SPEED SENSING & HYDRAULIC LIFT  
810 PTO CHIPPER - DWG #22

Below is a quick reference chart for various "Flat Head Cap Screws" and the torque recommendations.

**VALUES ARE STATED IN FOOT POUNDS**

BOLT SIZE	Thds Per Inch	SAE Grade 5	SAE Grade 8
1/4	20	10	14
	28	---	---
5/16	18	19	29
	24	---	---
3/8	16	33	47
	24	---	---
7/16	14	54	78
	20	---	---
1/2	13	78	119
	20	---	---
9/16	12	114	169
	18	---	---
5/8	11	154	230
	11	---	---
3/4	10	257	380
	10	---	---
7/8	9	382	600
	9	---	---
1	8	587	700
	8	---	---

Drive Belt Tension Measurement by Deflection

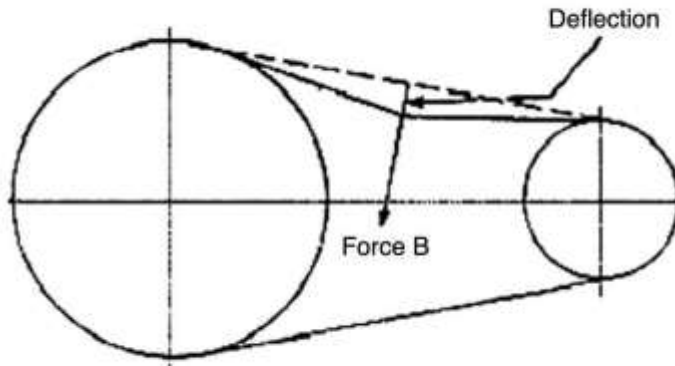

Deflection should be 3/8" when 8-12 lbs. push is applied at "B"

## WARRANTY POLICY

*Please remember to complete and return your Warranty Card and Dealer Delivery Report. Warranty Claims will not be considered if the Warranty Card and Dealer Delivery Report have not been returned to Salsco.*

Your Salsco Commercial or Turf Equipment product is a commercial type product and is normally manufactured and sold for commercial or industrial use. **Salsco will, for the original purchaser, for one (1) year from the date of purchase (90 days if used for rental purposes) repair or replace, free of charge, any SALSCO part or parts found to be defective in material, workmanship or both.** Any transportation or shipping charges will be borne by the purchaser. If, during the warranty period stated above, the product does not function properly due to defect, simply contact Salsco and follow the Warranty Procedures included in this manual.

This warranty **does not** include:

- Incidental or consequential damages and is exclusive of any implied warranties.
- Normal maintenance parts, including, but not limited to hoses, chains, belts, filters, lubricants, etc.
- Parts or components, which are covered under the original manufacturer warranty, including, but not limited to engines, pumps, and motors.

## WARRANTY PROCEDURE

In order for Salsco to consider your warranty claims in a timely manner you must follow the simple procedures listed below:

### MACHINE OR PART FAILURE

- Call our service department for helpful instruction on how to correct or repair the problem. Preventive maintenance will also be suggested.
- When ordering parts for Warranty issues, you **MUST** retain possession of the old parts in question until notified with respect to returning the parts to Salsco or other disposition.
- Warranty Claims **MUST** be filed within 30-days from completion of the work performed. Contact our office for an electronic warranty claim form.
- Fill in all information requested on warranty claim form, a copy of which is included in this manual, (date of purchase, company name, address, etc.). List all parts used. Make sure part numbers are correct. You can obtain these from your manual. (include good description of problem; i.e. "leaking from spool" rather than "leaking").
- It is our goal to consider and reach a disposition on each Warranty Claim within 30-days from the date that it is received. Therefore it is important that you respond promptly to any request for further information. Claims with no response to inquiries will be closed as "**denied for lack of response**" 90-days from the date of request.
- Email, Fax or Send Warranty Claim form to our Warranty Department. – **Warranty on parts most often requires return of the parts that were replaced.** **DO NOT DISCARD OLD PARTS UNTIL YOU HAVE RECEIVED A DETERMINATION AS TO WHETHER THESE PARTS MUST BE RETURNED.**
- Our Warranty Department will contact and instruct you on how to return the Parts to Salsco on an RA #. Returns **MUST** be made within 30-Days from issuance of RA #. **FREIGHT CHARGES ON RETURN OF PARTS IS THE RESPONSIBILITY OF THE CUSTOMER.** Normal pre-delivery adjustments are not covered under warranty. Labor Warranties are based on reasonable time allowances as determined by Salsco, Inc. and paid at 75% of posted labor rate. **TRAVEL TIME IS NOT REIMBURSED UNDER THE WARRANTY POLICY.**
- Be sure to put the RA form inside the box that you are shipping back, also be sure to put on the outside of the box "Return of Goods" and the RA #.
- Ship returns via a traceable method such as UPS Ground Service. Be sure that the shipment is insured for the appropriate value. If uninsured parts are lost, we cannot issue a credit.

**PLEASE NOTE:**        *Warranty forms should be filled out completely.*

**PREVENTIVE MAINTENANCE IS YOUR BEST INSURANCE AGAINST EQUIPMENT FAILURE. BE SURE TO READ THIS MANUAL, ESPECIALLY THE MAINTENANCE, OPERATING AND CAUTION SECTIONS.**

SALSCO, INC., 105 School House Rd.  
Cheshire, CT 06410  
800-872-5726, 203-271-1682  
203-271-2596 (Fax)  
sales@salsco.com, [www.salsco.com](http://www.salsco.com)

**WARRANTY CLAIM FORM**

SALSCO, INC.  
105 School House Rd.  
Cheshire, CT 06410

Phone: (203) 271-1682, (800) 872-5726  
Fax: (203) 271-2596  
Email: s.clark@salsco.com  
Website: www.salsco.com

**END OWNER**

Date Submitted:

Name:	Phone:	Work Order #:
Email:	Fax:	Office Use Only
Address:		Date Rec'd
		Cust ID:
		Salsco WC
		Salsco RA

**PURCHASED FROM**

Name:	Phone:	Date Rejected:
Email:	Fax:	Processed By:
Address:		Dir. Del Report on File: YES NO
		Warranty Card on File: YES NO
		Part(s) Total:

**Equipment/Warranty Information (Must be complete)**

Purchase Date:	Invoice #	Date Failed:	Labor Total:
			Total Approved:
Model #:	Serial #:	Repair Date:	Approved/Rejected:
			Name:
Hrs Used:	Primary Use:		Reason for Rejection:
Warranty Claim/Work Order#:			
Was a Salsco Return Authorization # issued for repairs or			
Return of Parts?	YES	NO	Suggested Preventative Maint:
Probable Cause of Failure:			

**Work Performed/Comments on Repair:**

Shop Labor Rate:						Submitted By:		
Total Labor Hours to Repair:						Printed Name:		
Parts Required for repair								
Salsco Part #: Description:					Qty.	Price Each	Total	Inv #
							\$	
							\$	
							\$	
							\$	

Fill in all information requested on warranty claim form.  
**INCOMPLETE FORMS CANNOT BE PROCESSED & WILL BE RETURNED**  
List all parts used. Make sure part numbers are correct. Any parts that you believe to be defective or any parts that break should be retained for possible inspection until after the warranty has been paid or part has been replaced.

