

**Salsco, INC.**  
LEADER BY DESIGN

**MADE IN THE U.S.A**

**OPERATORS AND PARTS MANUAL  
MODELS 413H, 416B, 425S**



**MANUFACTURER OF OUTDOOR POWER EQUIPMENT**

Products for Turf & Lawn care, Rental, Construction, Tree care, Wood Processing, Nursery & Farm Industries

*Other Salsco Equipment*

**3-1/2" - 18", Gas, Diesel, and P.T.O, Wood/Brush Chippers  
Chipper Shredder Vacuums - Tailgate & Truckloader Vacuums  
Shaving Mills - Gas and Electric Greens Rollers**

---

***Quality of Workmanship, Innovative  
Design, Built to Last!***

105 School House Road  
Cheshire, CT 06410 U.S.A.  
800-872-5726, 203-271-1682, 203-271-2596 (Fax)  
sales@salsco.com, www.salsco.com

**TABLE OF CONTENTS**

**MODELS 413H & 416B CHIPPERS**  
**FOR UNITS WITH SERIAL NUMBER 13.....4214 AND BELOW**

COVER & TABLE OF CONTENTS.....Pages 1 – 2

STATEMENT OF FACT ..... Page 3

SPECIFICATIONS & FEATURES .....Page 4

MACHINE REGISTRATION .....Page 5

SAFETY & OPERATING INSTRUCTIONS .....Pages 6 - 9

SERVICE & MAINTENANCE INSTRUCTIONS .....Pages 10

PARTS DIAGRAMS ..... Pages 11 - 17

TORQUE CHARTS .....Pages 18

WARRANTY POLICY/PROCEDURE .....Page 19

COPY OF WARRANTY CLAIM FORM.....Page 20

COPY OF DEALER DELIVERY REPORT & WARRANTY CARD.....Page 21

SERVICE SCHEDULE LOG .....Page 22

SALSCO, INC.  
105 School House Road  
Cheshire, CT 06410  
800-872-5726, 203-271-1682

## **STATEMENT OF FACT**

You have just purchased the highest quality, most dependable, chipper on the market today. This unit has the ability to meet exact standards and perform for years with minimum downtime. **HOWEVER**, it cannot read nor will it understand this manual no matter how long you leave it on top of the machine.

**It is your responsibility** to read and understand this manual; it is also your responsibility to be certain this information is passed along to anyone who is expected to operate this equipment. Should you choose not to read, understand and pass along the information provided you, please expect equipment failure and possible injuries to persons around this equipment.

For the safety of the operator, it is **imperative** that this manual is carefully read and understood.

Once you have read this manual, it is your responsibility to be sure that all new operators read and understand this manual, especially all cautions stated.

As a manufacturer of equipment, we have a responsibility to design a safe piece of equipment. **NOTE:** The important safeguards and instructions in this manual are not meant to cover all possible conditions and situations that may occur. It must be understood that common sense, caution, and care are factors, which cannot be built into any product. These factors must be supplied by the person(s) caring for and operating this equipment.

**ONLY YOU CAN PREVENT ACCIDENTS!!**

## SPECIFICATIONS & FEATURES

### SPECIFICATIONS - MODEL 413H & 416B

<b>INFEED CHUTE:</b>	22-1/4" X 22-1/4". Plastic Strips for Safety.
<b>EXHAUST CHUTE:</b>	360° Swivel Chute with Adjustable Chip Deflector. No tools necessary for adjustment.
<b>CHIPPER DISC:</b>	22-1/8" diameter x 3/4" thick.
<b>CHIP BLADES:</b>	1/2" thick x 4" wide x 7-1/4" long. Hardened & Double Sided. Qty. 2.
<b>CHIPPER DISC HOUSING:</b>	7 Gauge Thick Steel Impeller Housing is Vented to Provide More Air Flow for Chip Exhaust.
<b>INFEED OPENING:</b>	4" x 5".
<b>BED KNIFE:</b>	Replaceable, Sharpenable, Adjustable - 1/2" Thick Steel.
<b>BEARINGS:</b>	Heavy Duty, Cast Iron, Greaseable & Self Centering.
<b>FRAME:</b>	7 Gauge Steel Frame, Fully Gusseted for Strength.
<b>AXLE:</b>	Tor-flex - 1000 lb. Capacity Torsion Axle
<b>BATTERY:</b>	12 Volt
<b>TONGUE:</b>	2" X 3" X 1/4" Wall, Rectangular Steel Tube. 2" Ball Coupler, Safety Chains & 2,000 lb. Capacity, Top Wind Jack.
<b>PAINT:</b>	Orange, Polyester Powder Coat Paint, provides excellent outdoor weatherability & offers protection against ultra violet discoloration.
<b>TIRES:</b>	18.5 X 8.50 - 8
<b>OPTIONS:</b>	13HP Honda, Electric Start - 16HP Briggs & Stratton Vanguard, Electric Start.
<b>DIMENSIONS:</b>	Length - 102", Width - 60", Height to top of discharge - 75". Weight - 1200 lbs.

Specifications & Options Subject to Change without Notice.

Rev. 3/06

**MACHINE REGISTRATION**

MANUFACTURED BY: SALSCO, INC.  
105 School House Rd., Cheshire, CT 06410  
800-872-5726, 203-271-1682, 203-271-2596 (Fax)  
[sales@salsco.com](mailto:sales@salsco.com) [www.salsco.com](http://www.salsco.com)

THIS MANUAL COVERS MODEL (s): 413H & 416B CHIPPERS

This company reserves the right to discontinue, add improvements to, or change the design of any model or product at any time without obligation to improve existing machines, either by changing the design or adding new parts.

It has been and will continue to be the policy of SALSCO to update existing machines at its own discretion. Whenever possible, new designs will be made in such a way that they can be "Retro Fit" if so desired.

Record in the space provided below the model and serial number of this unit. Please retain these numbers for future reference.

No parts orders will be accepted **WITHOUT MODEL NUMBERS OR PART NUMBERS**. All part numbers are listed in this manual.

\_\_\_\_\_

Serial Number

\_\_\_\_\_

Model Number

NOTE: Be sure to complete your warranty card. This will insure immediate processing of any warranty claims.

**READ AND UNDERSTAND THIS MANUAL BEFORE STARTING THE MACHINE**

1/06

## **BRUSH CHIPPERS ANSI Z133.1-2006**

### **American National Standard for Arboricultural Operations Safety Requirements**

#### **5.3 Brush Chippers**

- 5.3.1 The items contained in section 5.1 shall always be included in the review of this section.
- 5.3.2 Access panels (for example, guards) for maintenance and adjustment, including discharge chute and cutter housing, shall be closed and secured prior to starting the engine of brush chippers. These access panels shall not be opened or unsecured until the engine and all moving parts have come to a complete stop (see Annex C, General Safety Procedures That Apply to All Tree Work).
- 5.3.3 Rotary drum or disc brush chippers not equipped with a mechanical infeed system shall be equipped with an infeed hopper not less than 85 inches (2.15 m) measured from the blades or knives to ground level over the center line of the hopper. Side members of the infeed hopper shall have sufficient height so as to prevent workers from contacting the blades or knives during operations.
- 5.3.4 Rotary drum or disc brush chippers not equipped with a mechanical infeed system shall have a flexible anti-kickback device installed in the infeed hopper to reduce the risk of injury from flying chips and debris.
- 5.3.5 Chippers equipped with a mechanical infeed system shall have a quick-stop and reversing device on the infeed system. The activating mechanism for the quick-stop and reversing device shall be located across the top, along each side, and close to the feed end of the infeed hopper within easy reach of the worker.
- 5.3.6 Vision, hearing, and/or other appropriate personal protective equipment shall be worn when in the immediate area of a brush chipper in accordance with section 3.4, Personal Protective Equipment.
- 5.3.7 Arborists, mechanics, and other workers shall not, under any circumstances, reach into the infeed hopper when the cutter disc, rotary drum, or feed rollers are moving.
- 5.3.8 When trailer chippers are detached from the vehicles, they shall be chocked or otherwise secured in place.
- 5.3.9 When in a towing position, chipper safety chains shall be crossed under the tongue of the chipper and properly affixed to the towing vehicle.
- 5.3.10 See section 8.6, Brush Removal and Chipping, for additional requirements.

**BRUSH REMOVAL AND CHIPPING**  
**ANSI Z133.1-2006**  
American National Standard for Arboricultural Operations  
Safety Requirements

**8.6 Brush Removal and Chipping**

- 8.6.1 Traffic control around the jobsite shall be established prior to the start of chipping operations along roads and highways (see section 3.2, Traffic Control Around the Jobsite).
- 8.6.2 Brush and logs shall not be allowed to create hazards in the work areas.
- 8.6.3 To prevent an entanglement hazard, loose clothing, climbing equipment, body belts, harnesses, lanyards, or gauntlet-type gloves (for example, long-cuffed lineman's or welder's gloves) shall not be worn while operating chippers.
- 8.6.4 Personal protective equipment shall be worn when in the immediate area of chipping operations in accordance with section 3.4, Personal Protective Equipment, of this standard.
- 8.6.5 Training shall be provided in the proper operation, feeding, starting, and shutdown procedures for the chipper being used.
- 8.6.6 Maintenance shall be performed only by those persons authorized by the employer and trained to perform such operations.
- 8.6.7 Brush and logs shall be fed into chippers, butt or cut end first, from the side of the feed table center line, and the operator shall immediately turn away from the feed table when the brush is taken into the rotor or feed rollers. Chippers should be fed from the curb-side whenever practical.
- 8.6.8 The brush chipper discharge chute or cutter housing cover shall not be raised or removed while any part of the chipper is turning or moving. Chippers shall not be used unless a discharge chute of sufficient length or design is provided that prevents personal contact with the blades (see Annex C, General Safety Procedures That Apply to All Tree Work).
- 8.6.9 Foreign material, such as stones, nails, sweepings, and rakings, shall not be fed into chippers.
- 8.6.10 Small branches shall be fed into chippers with longer branches or by being pushed with a long stick.
- 8.6.11 Hands or other parts of the body shall not be placed into the infeed hopper. Leaning into or pushing material into infeed hoppers with feet is prohibited.
- 8.6.12 While material is being fed into the chipper infeed hopper chute, pinch points continually develop within the material being chipped and between the material and machine. The operator shall be aware of this situation and respond accordingly.
- 8.6.13 When feeding a chipper during roadside operations, the operator shall do so in a manner that prevents him or her from stepping into traffic or being pushed into traffic by the material that is being fed into the chipper.
- 8.6.14 When using a winch in chipper operations, the operator shall ensure that the winch cable is properly stored before initiating chipper operations.
- 8.6.15 Refer to section 5.3, Brush Chippers, for additional information.

## CAUTIONS

READ THOROUGHLY THE OPERATOR SAFETY INSTRUCTIONS ON THE FOLLOWING THREE PAGES, WHICH ARE THE AMERICAN NATIONAL STANDARD OF POWERED SHREDDERS/GRINDERS, SAFETY SPECIFICATIONS PROVIDED BY ANSI AND THE O.P.E.I.

THE FOLLOWING CAUTIONS ARE PROVIDED BY SALSCO AS A QUICK REFERENCE ONLY AND ARE NOT MEANT TO REPLACE THE PRECAUTIONS ON THE FOLLOWING PAGES.

1. **ALWAYS** use protective eyewear when machine is in operation.
2. **ALWAYS** use gloves and wear ear protection when machine is in operation.
3. **NEVER** put hands, legs or any part of your body into or near Chipper intake or discharge openings.
4. **NEVER** run with guards removed.
5. **ALWAYS** allow machine to cool off, remove key and put engine in neutral before attempting any maintenance, or repair.
6. **BE SURE** machine has stopped completely, engine is off, key is removed and spark plug is disconnected before attempting any service or maintenance.
7. **NEVER** stand in front of chipper infeed hopper. It is possible for a chip or piece of wood to be thrown out.
8. **BE SURE** the machine is parked on a dry level surface before starting operation.
9. **DO NOT** operate with loose clothing or long unrestrained hair. Be sure vines and branches are not wrapped around your body parts.
10. **DO NOT** operate on ice or any other slippery surface. Be sure area around machine is clear and clean. You do not want to trip into the machine.
11. **NEVER** leave machine running unattended, especially around youngsters or persons not instructed in the safe operation of this machine.

**READ and understand federal guidelines provided with this manual.**



## OPERATING INSTRUCTIONS

- 1) Be sure all guards and covers are in place.
- 2) Check all chambers to be sure they are free and clear of debris.
- 3) Set direction of discharge chute.
- 4) Start engine, bring up to full R.P.M.
  
- 6) Begin feeding material into the machine. **NOTE:** You should be standing, looking at the infeed hopper opening, as you place material into the machine. Turn to your left and exit the area. Go and get another branch, do not worry about the chipper, it will take care of itself. Should there be any wood left in the infeed, it will be taken care of by the next branch. **DO NOT REACH INTO THIS MACHINE FOR ANY REASON!**
  
- 7) When you are done chipping, let the machine come down to an idle for a few minutes before shutting down.

## HINTS

- 1) When operating machine, stand off to the side of the feed hopper when feeding wood into the machine. **NEVER STAND DIRECTLY IN FRONT OF THE FEED HOPPER WHEN FEEDING WOOD INTO THE MACHINE.**
- 2) When using the chipper and you have a short piece of wood bouncing around and not being grabbed by the feed roll, **LEAVE IT! DO NOT TRY TO PUSH IT THROUGH WITH ARMS OR LEGS!** The next limb will push it through.
- 3) When through with the job, make sure all material is run through the machine before shutting it down. This will prevent any injuries from flying debris when the machine is started up at the next job.

**REMEMBER! A CHIPPER WILL ONLY LET YOU MAKE A STUPID MISTAKE ONCE!**

## SERVICE SCHEDULE

1. **Grease** all main bearings once a day. **DO NOT OVER GREASE.** Wipe extra grease off bearings.
2. Be sure to **clean** entire machine. Should it become necessary to remove the exhaust chute, to clean out the machine, make sure the key has been removed from the engine.
3. **Sharpen/change chipper blades: REMOVE KEY FROM ENGINE.** Remove bolt on impeller housing. Open impeller housing to expose impeller and chipper blades. **Do not** reach in and hold impeller with your hand, instead use a piece of 2" x 4" wood to push impeller housing. When you reassemble, be sure to use Locktite. We use Locktite, Blue 242, removable at the factory. It is also advisable to discard bolts and replace them with new bolts. Sharpen blades as you would sharpen a lawn mower blade, under angle edge only. Sharpen blades as evenly as possible. **REMINDER!** SALSCO, INC. has a blade sharpening service. Call SALSCO, INC. for full details, 800-872-5726.
4. **Recommended Bed knife adjustment** is 3/16" from chipper blades. When adjusting bed knife, check the distance on all chipper blades. **MAKE SURE** all bolts are tightened properly after adjusting bed knife.  
**HINT:** It is strongly recommended to have a set of blades and screws on the shelf, to prevent downtime while blades are being sharpened.  
**HINT:** Blades need sharpening after approximately 8 - 15 hours of use.

SERVICE SCHEDULE	AS NEEDED	DAILY	WEEKLY	MONTHLY
CLEAN MACHINE	X	X		
GREASE DISC SHAFT BEARING	X	X		
SHARPEN CHIPPER BLADES	X OR		X	
CHECK & ADJUST BED KNIFE	X OR		X	
CHECK ALL NUTS & BOLTS	X	X		

CHECK ENGINE MANUAL FOR ENGINE MAINTENANCE SCHEDULE

**NEVER, UNDER ANY CIRCUMSTANCES START THE ENGINE WHEN UNIT IS OPEN OR AT ANY TIME DURING SERVICE OR ROUTINE MAINTENANCE**

REV	DESCRIPTION	DATE

ISSUED: 06-06-2006

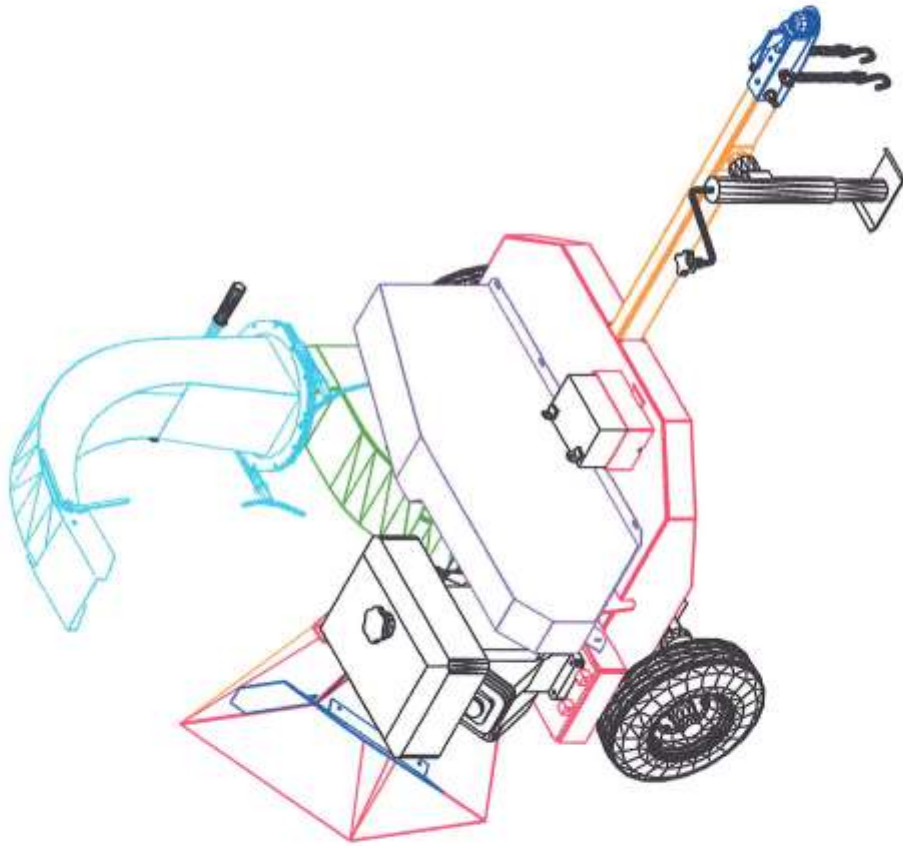

413 / 416 CHIPPER ASSY - DWG #1

ISSUED: 07-05-2007

ITEM	DESCRIPTION	PART NO	QTY	ITEM	DESCRIPTION	PART NO	QTY
1	HSG, IMPL. LOWR & TOWFRAME	0228261	1	5	WASHER, FLAT	0353181	2
2	TONGUE, TOWFRAME	0225083	1	6	NUT, NYLON LOCK	0346422	2
3	HEX HEAD BOLT	0346410	1	7	2" COUPLER	0325007	1
4	HEX HEAD BOLT	0346422	1	8	SPACER, SAFETY CHAIN	0449203	2
				9	SAFETY CHAIN	0309018	2
				10	JACK, TOP WIND	0369006	1
				11	AXLE, TORFLEX	0302100	1
				12	LUG NUT, 1/2-20	0338306	10
				13	TIRE / WHEEL ASSY	0354020	2

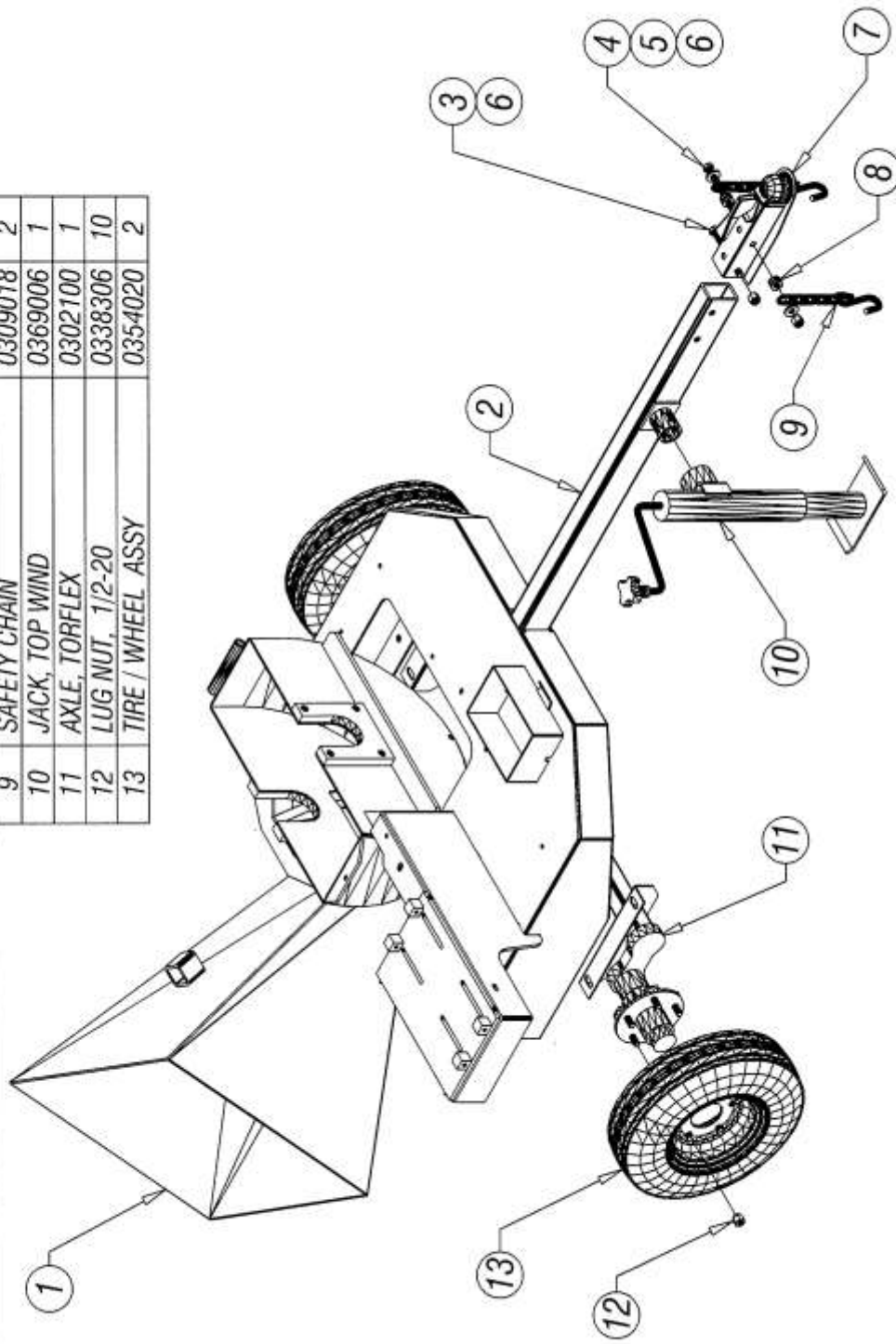

413 / 416 CHIPPER - DWG #2

REV	DESCRIPTION	DATE

ISSUED: 06-06-2006

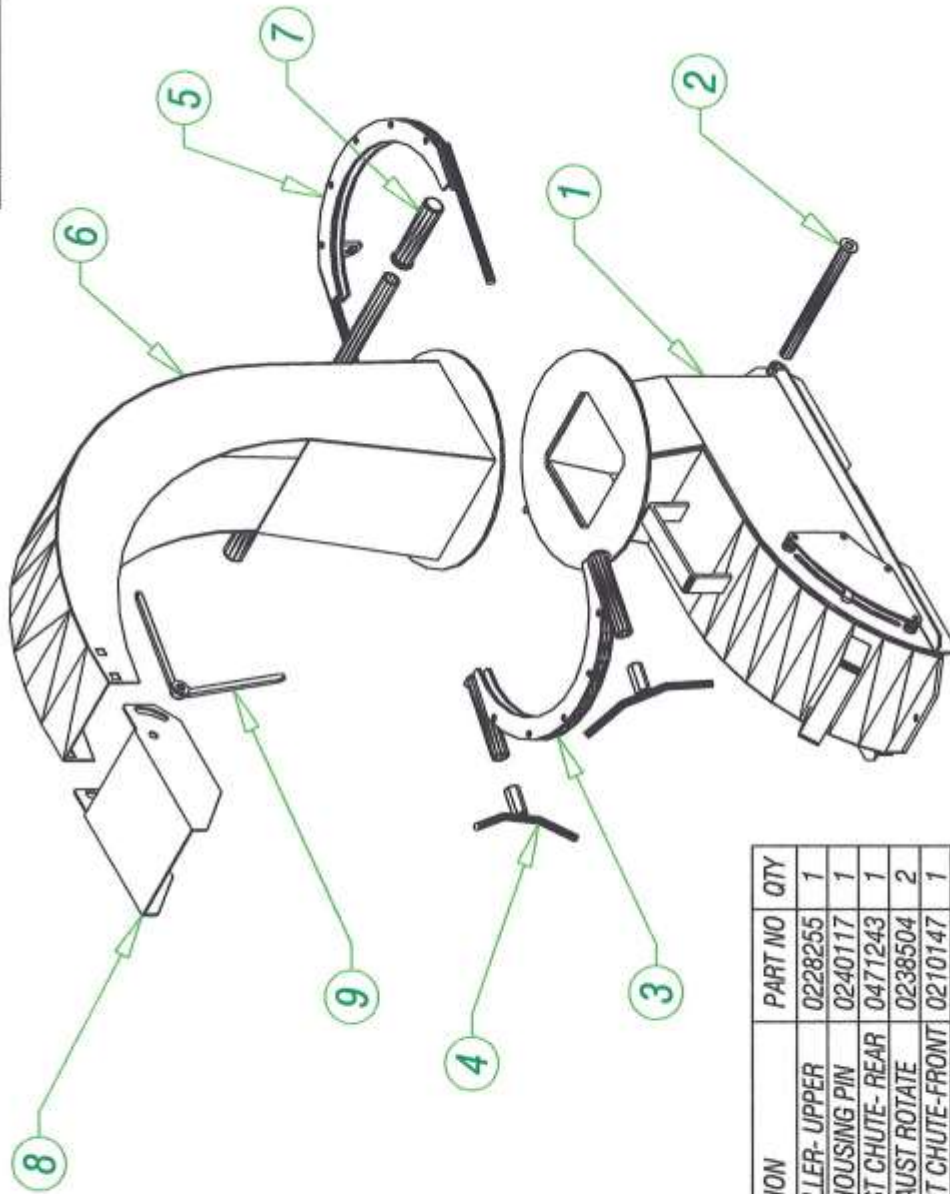

413 / 416 CHIPPER - DWG #3

ITEM	DESCRIPTION	PART NO	QTY
1	HOUSING, IMPELLER- UPPER	0228255	1
2	PIN, IMPELLER HOUSING PIN	0240117	1
3	CLAMP, EXHAUST CHUTE- REAR	0471243	1
4	WING NUT- EXHAUST ROTATE	0238504	2
5	CLAMP, EXHAUST CHUTE-FRONT	0210147	1
6	CHUTE, EXHAUST	0226147	1
7	RUBBER GRIP	0332009	2
8	EXHAUST CHUTE DEFLECTOR	0471194	1
9	WING NUT- DEFLECTOR	0238500	1

-ISSUED: 06-06-2006-  
-ISSUED: 02-07-2011-  
ISSUED: 06-18-2012

ITEM	DESCRIPTION	PART NO	QTY	ITEM	DESCRIPTION	PART NO	QTY
1	ENGINE, 16 HP B&S VANGUARD	0337328	1	10	FLAT WASHER	0353110	4
2	MUFFLER KIT FOR 16 HP	0337434	1	11	SPUT LOCK WASHER	0353014	4
3	ENGINE, 13 HP HONDA JMUF INCL	0337033	1	12	BEARING, 4-BOLT, FLANGED	0303059	2
4	SHAFT, IMPELLER	0248251	1	13	NUT, STOVER	0338154	6
5	CENTRIFUGAL CLUTCH / PULLEY	SEE NOTE	-	14	SPUT LOCK WASHER	0353017	6
6	SHEAVE, 15.8" OD	0342164	1	15	BLADE, CHIP	0305047	2
7	BUSHING, 2" ID	0342029	1	16	FLAT HD, SOCKET CAP SCREW	0346486	6
8	V-BELT	SEE NOTE	-				
9	BOLT, HEX HEAD	0346503	4				

**NOTE:** MACH. S/N's 2278 & PREVIOUS, USE  
ITEM # 5 (CLUTCH) PIN 0337446.  
ITEM # 8 (2 SINGLE V-BELTS) PIN 0304114  
MACH. S/N's 2858 & ABOVE, USE  
ITEM # 5 (CLUTCH) PIN 0337465  
ITEM # 8 (2-BELT BANDED) PIN 0304119  
IF EITHER ONE OF THE CLUTCHES ABOVE  
NEED TO BE REPLACED, YOU WILL NEED  
TO ORDER THE FOLLOWING, AS THE OLDER  
CLUTCHES ARE NO LONGER AVAILABLE.  
ITEM #5 - 0337593 - CLUTCH  
ITEM #6 - 0342265 - SHEAVE  
ITEM #8 - 0304184 - V-BELT

413 / 416 CHIPPER - DWG #4

FOR UNITS WITH THE 25HP SUBARU ENGINE, PLEASE NOTE THE FOLLOWING CHANGES:

ITEM	DESCRIPTION	PART NO	QTY
5	CENTRIFUGAL CLUTCH	0337377	1
6	SHEAVE	0342043	1
8	V-BELT	0304188	1
N/A	FUEL TANK-6 GALLON CARB FUEL TANK	0352111	1

REV	DESCRIPTION	DATE

ISSUED: 06-06-2006

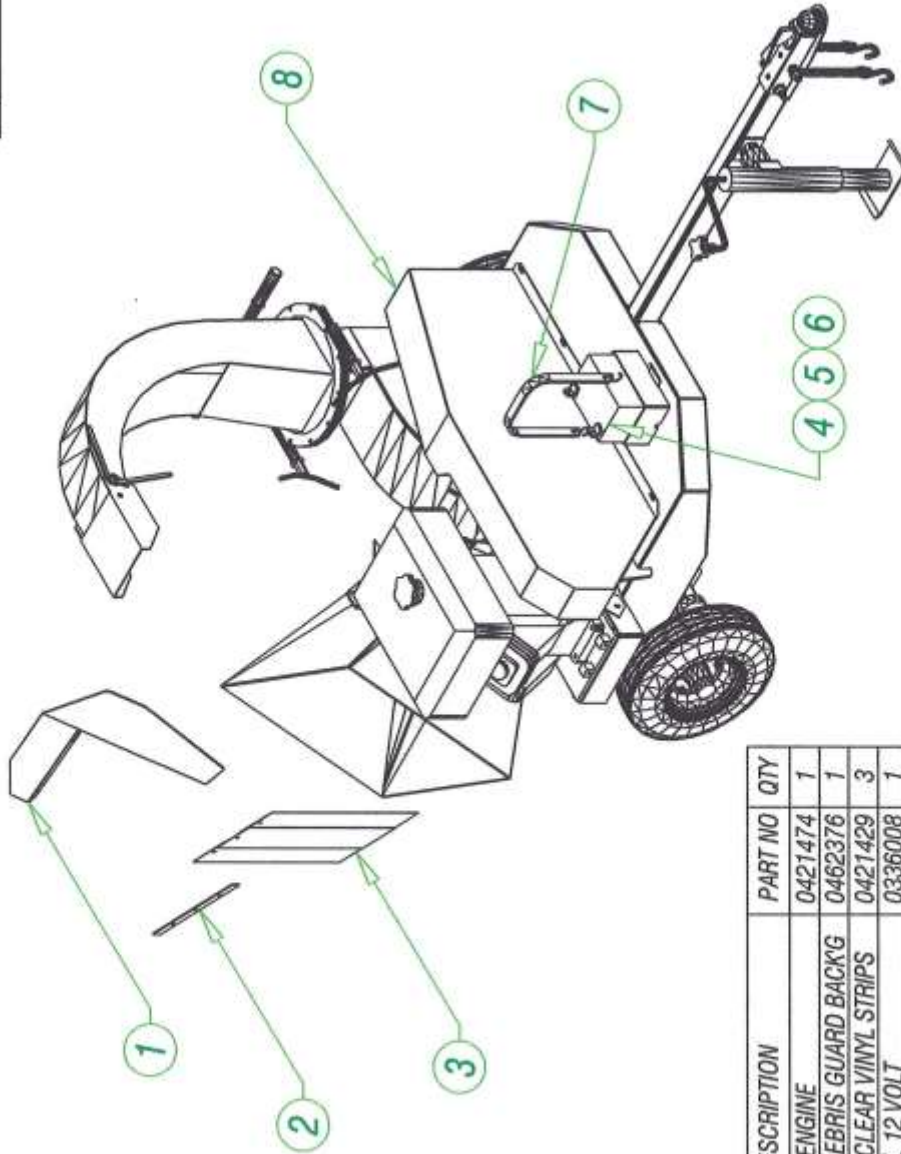

413 / 416 CHIPPER - DWG #5

ITEM	DESCRIPTION	PART NO	QTY
1	GUARD, ENGINE	0421474	1
2	PLATE, DEBRIS GUARD BACKG	0462376	1
3	GUARD, CLEAR VINYL STRIPS	0421429	3
4	BATTERY, 12 VOLT	0336008	1
5	BATTERY CABLE, NEG. - 34" LG	0415336	1
6	BATTERY CABLE, POS. - 40" LG	0415337	1
7	10" BUNGEE CORD	0308013	1
8	GUARD, BELT DRIVE	0221473	1

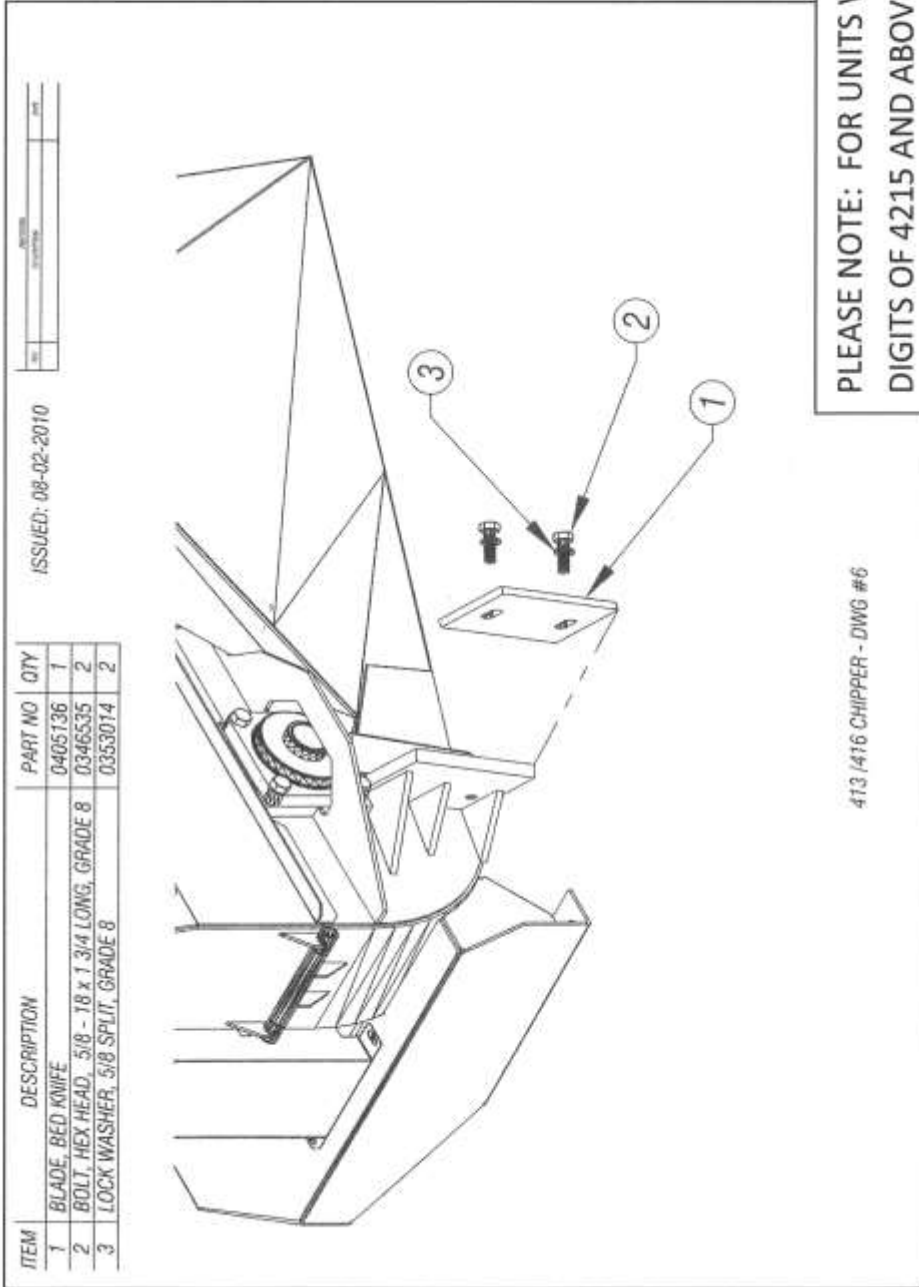

PLEASE NOTE: FOR UNITS WITH THE LAST 4 DIGITS OF 4215 AND ABOVE USE PART # 040140 WHEN ORDERING ITEM # 1, BED KNIFE BLADE.

413 /416 CHIPPER - DWG #6



ITEM	DESCRIPTION	PART NO	QTY
1	XXXXX	XXXXX	X

REV	DESCRIPTION	DATE

ISSUED: 08-02-2010

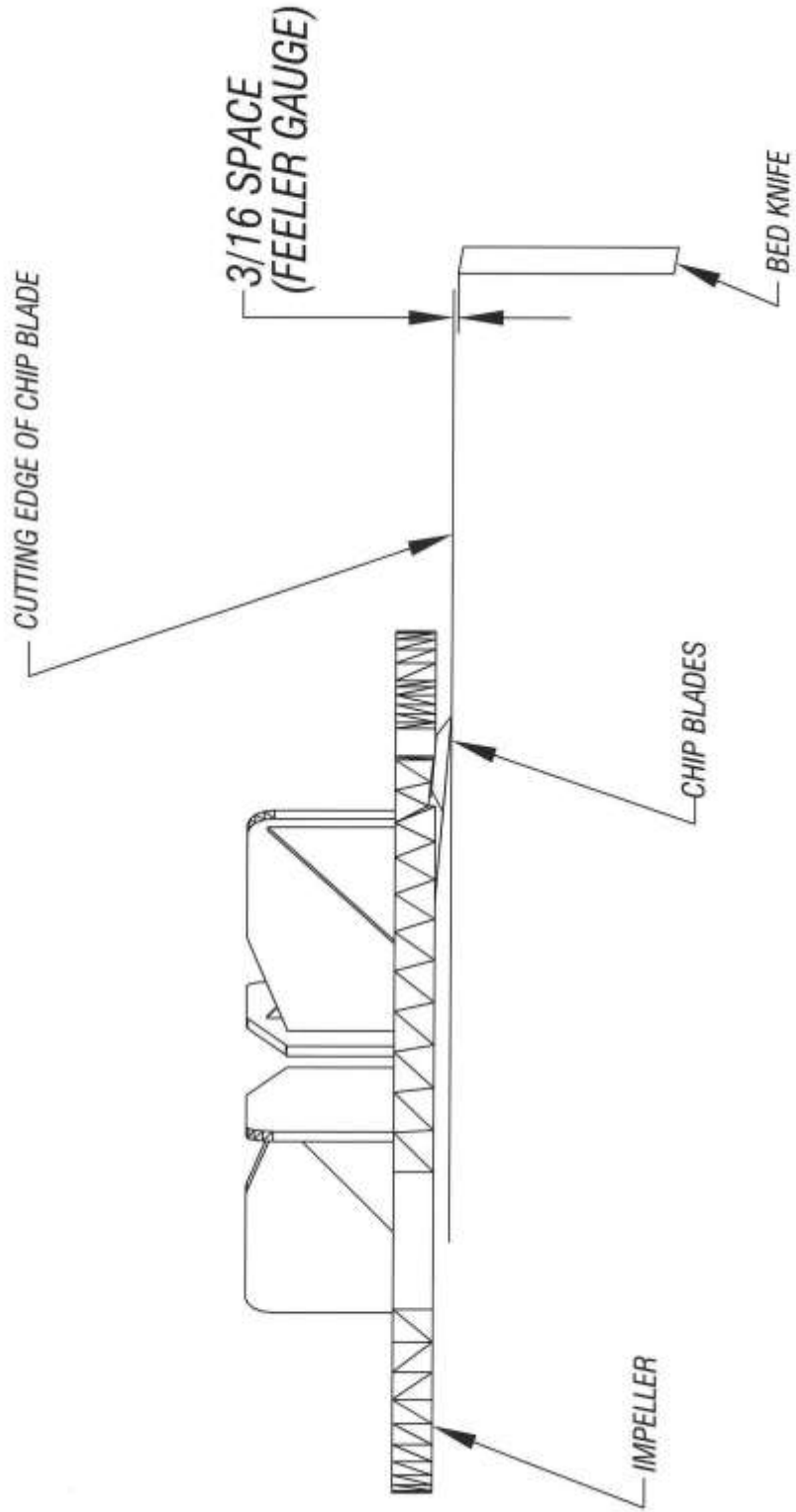

BLADE, BED KNIFE ADJUSTMENT  
413 / 416 CHIPPER - DWG #7

Below is a quick reference chart for various “Flat Head Cap Screws” and the torque recommendations.

**VALUES ARE STATED IN FOOT POUNDS**

BOLT SIZE	Thds Per Inch	SAE Grade 5	SAE Grade 8
1/4	20	10	14
	28	---	---
5/16	18	19	29
	24	---	---
3/8	16	33	47
	24	---	---
7/16	14	54	78
	20	---	---
1/2	13	78	119
	20	---	---
9/16	12	114	169
	18	---	---
5/8	11	154	230
	11	---	---
3/4	10	257	380
	10	---	---
7/8	9	382	600
	9	---	---
1	8	587	700
	8	---	---

Drive Belt Tension Measurement by Deflection

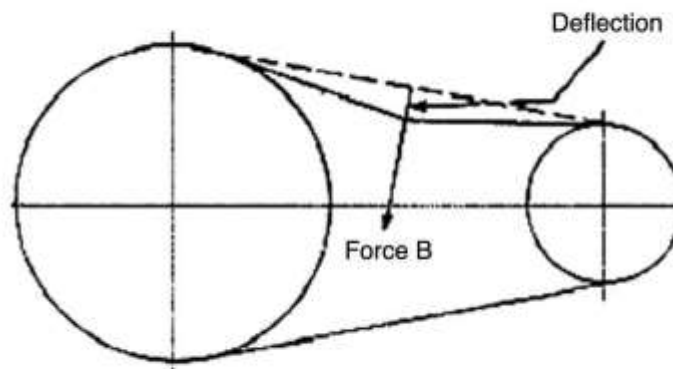

Deflection should be 3/8" when 8-12 lbs. push is applied at "B"

## WARRANTY POLICY

**Please remember to complete and return your Warranty Card and Dealer Delivery Report. Warranty Claims will not be considered if the Warranty Card and Dealer Delivery Report have not been returned to Salsco.**

Your Salsco Commercial or Turf Equipment product is a commercial type product and is normally manufactured and sold for commercial or industrial use. Salsco will, for the original purchaser, for one (1) year from the date of purchase (90 days if used for rental purposes) repair or replace, free of charge, any SALSCO part or parts found to be defective in material, workmanship or both. Any transportation or shipping charges will be borne by the purchaser. If, during the warranty period stated above, the product does not function properly due to defect, simply contact Salsco and follow the Warranty Procedures included in this manual.

This warranty **does not** include:

- Incidental or consequential damages and is exclusive of any implied warranties.
- Normal maintenance parts, including, but not limited to hoses, chains, belts, filters, lubricants, etc.
- Parts or components, which are covered under the original manufacturer warranty, including, but not limited to engines, pumps, and motors.

## WARRANTY PROCEDURE

In order for Salsco to consider your warranty claims in a timely manner you must follow the simple procedures listed below:

### MACHINE OR PART FAILURE

- Call our service department for helpful instruction on how to correct or repair the problem. Preventive maintenance will also be suggested.
- When ordering parts for Warranty issues, you **MUST** retain possession of the old parts in question until notified with respect to returning the parts to Salsco or other disposition.
- Warranty Claims **MUST** be filed within 30-days from completion of the work performed. Contact our office for an electronic warranty claim form.
- Fill in all information requested on warranty claim form, a copy of which is included in this manual, (date of purchase, company name, address, etc.). List all parts used. Make sure part numbers are correct. You can obtain these from your manual. (include good description of problem; i.e. "leaking from spool" rather than "leaking").
- It is our goal to consider and reach a disposition on each Warranty Claim within 30-days from the date that it is received. Therefore it is important that you respond promptly to any request for further information. Claims with no response to inquiries will be closed as "**denied for lack of response**" 90-days from the date of request.
- Email, Fax or Send Warranty Claim form to our Warranty Department. – **Warranty on parts most often requires return of the parts that were replaced. DO NOT DISCARD OLD PARTS UNTIL YOU HAVE RECEIVED A DETERMINATION AS TO WHETHER THESE PARTS MUST BE RETURNED.**
- Our Warranty Department will contact and instruct you on how to return the Parts to Salsco on an RA #. Returns **MUST** be made within 30-Days from issuance of RA #. **FREIGHT CHARGES ON RETURN OF PARTS IS THE RESPONSIBILITY OF THE CUSTOMER.** Normal pre-delivery adjustments are not covered under warranty. Labor Warranties are based on reasonable time allowances as determined by Salsco, Inc. and paid at 75% of posted labor rate. **TRAVEL TIME IS NOT REIMBURSED UNDER THE WARRANTY POLICY.**
- Be sure to put the RA form inside the box that you are shipping back, also be sure to put on the outside of the box "Return of Goods" and the RA #.
- Ship returns via a traceable method such as UPS Ground Service. Be sure that the shipment is insured for the appropriate value. If uninsured parts are lost, we cannot issue a credit.

**PLEASE NOTE:**     *Warranty forms should be filled out completely.*

**PREVENTIVE MAINTENANCE IS YOUR BEST INSURANCE AGAINST EQUIPMENT FAILURE. BE SURE TO READ THIS MANUAL, ESPECIALLY THE MAINTENANCE, OPERATING AND CAUTION SECTIONS.**

SALSCO, INC., 105 School House Rd.  
Cheshire, CT 06410  
800-872-5726, 203-271-1682  
203-271-2596 (Fax)  
sales@salsco.com, [www.salsco.com](http://www.salsco.com)

**WARRANTY CLAIM FORM**

SALSCO, INC.  
105 School House Rd.  
Cheshire, CT 06410

Phone:(203) 271-1682,(800) 872-5726  
Fax: (203) 271-2596  
Email: s.clark@salsco.com  
Website: www.salsco.com

**END OWNER**

**Date Submitted:**

Name:	Phone:	Work Order #:
Email:	Fax:	Office Use Only
Address:		Date Rec'd
		Cust ID:
		Salsco WC
		Salsco RA

**PURCHASED FROM**

Name:	Phone:	Date Approved:
Email:	Fax:	Date Rejected:
Address:		Processed By:
		Dir. Del Report on File: YES NO
		Warranty Card on File: YES NO
		Part(s) Total:
		Labor Total:

**Equipment/Warranty Information (Must be complete)**

Purchase Date:	Invoice #	Date Failed:	Total Approved:
Model #:	Serial #:	Repair Date:	Approved/Rejected:
Hrs Used:	Primary Use:		Name:
Warranty Claim/Work Order#:			Reason for Rejection:
Was a Salsco Return Authorization # issued for repairs or			
Return of Parts? YES NO			Suggested Preventative Maint:
Probable Cause of Failure:			

**Work Performed/Comments on Repair:**

Shop Labor Rate:						Submitted By:		
Total Labor Hours to Repair:						Printed Name:		
Parts Required for repair								
Salsco Part #: Description:					Qty.	Price Each	Total	Inv #
							\$	
							\$	
							\$	
							\$	

Fill in all information requested on warranty claim form.

**INCOMPLETE FORMS CANNOT BE PROCESSED & WILL BE RETURNED**

List all parts used. Make sure part numbers are correct. Any parts that you believe to be defective or any parts that break should be retained for possible inspection until after the warranty has been paid or part has been replaced.

800-872-5726  
203-271-2596 (Fax)

## Salsco, Inc.

105 School House Rd.  
Cheshire, CT 06410  
203-271-1682

sales@salsco.com  
www.salsco.com

### DEALER DELIVERY REPORT

MODEL		SERIAL NO				
DEALER		CITY	STATE	ZIP		
PURCHASER (Last Name or Company)	(First Name)	(Middle Name)	ADDRESS	CITY	STATE	ZIP

The undersigned dealer warrants that the above-described machine was carefully inspected, adjusted and prepared for delivery before delivery to the purchaser; that both the operation and maintenance of the machine were explained to the purchaser; and that a copy of the Owner's Instruction Manual were given to the purchaser and his attention called to Our Warranty and any operating instructions included in the manual and caution notes.

Date \_\_\_\_\_ Dealer \_\_\_\_\_  
Sign By \_\_\_\_\_  
Phone \_\_\_\_\_

The undersigned purchaser certifies that the operation and maintenance of the above-described machine have been explained to him; acknowledges receipt of a copy of the Owners's Instruction Manual and Our Warranty Policy printed in said Instruction Manual and Caution Notes. I also understand that it is my responsibility to explain and make Salsco manuals available to new operators.

Date \_\_\_\_\_ Purchaser \_\_\_\_\_  
Sign By \_\_\_\_\_  
Phone \_\_\_\_\_  
Email \_\_\_\_\_

FACTORY COPY WHITE - DEALER'S COPY YELLOW - OWNER'S COPY PINK

SERIAL #

MODEL NO.

### SALSCO LIMITED WARRANTY CARD

1. DATE PURCHASED: \_\_\_\_\_
2. PURCHASER: \_\_\_\_\_
3. PURCHASER ADDRESS: \_\_\_\_\_  
\_\_\_\_\_
4. EMAIL ADDRESS: \_\_\_\_\_
5. DEALER: \_\_\_\_\_
6. DEALER ADDRESS: \_\_\_\_\_
7. WILL THIS EQUIPMENT BE USED COMMERCIALY?  YES  NO
8. DID DEALER SERVICE THIS EQUIPMENT AND INSTRUCT YOU IN ITS CARE AND SAFE OPERATION ?  YES  NO
9. DID YOU RECEIVE AN "OPERATION & SERVICE MANUAL" AND SAFETY PAMPHLET?  YES  NO

## NOTICE

SIGNED \_\_\_\_\_  
Purchaser

IMPORTANT: THIS CARD MUST BE FILLED OUT COMPLETELY AND MAILED TO THE FACTORY WITHIN 10 DAYS OF PURCHASE DATE, OR YOUR LIMITED WARRANTY WILL BE VOIDED.

WHITE - DEALER

YELLOW - OWNER

CARD - FACTORY

