

Salsco, INC.
LEADER BY DESIGN

MADE IN THE U.S.A

OPERATORS AND PARTS MANUAL MODELS 608, 610 & 616 CHIPPER



MANUFACTURER OF OUTDOOR POWER EQUIPMENT

Products for Turf & Lawn care, Rental, Construction, Tree care, Wood Processing, Nursery & Farm Industries
Other Salsco Equipment

3-1/2" - 18", Gas, Diesel, and P.T.O, Wood/Brush Chippers

Chipper Shredder Vacuum - Tailgate & Truckloader Vacuums up to 65 HP

Shaving Mills - Gas and Electric Greens Rollers

***Quality of Workmanship, Innovative
Design, Built to Last!***

105 School House Road
Cheshire, CT 06410 U.S.A.
800-872-5726, 203-271-1682, 203-271-2596 (Fax)
sales@salsco.com, www.salsco.com

TABLE OF CONTENTS

MODEL (S) 608, 610 & 616 CHIPPERS

STATEMENT OF FACT.....Page 3

SPECIFICATIONS & FEATURESPage 4

MACHINE REGISTRATION.....Page 5

ANSI OPERATOR SAFETY INSTRUCTIONS.....Pages 6 - 7

OPERATING INSTRUCTIONSPage 8

SERVICE & MAINTENANCE INSTRUCTIONS.....Page 9

PARTS DIAGRAMS.....Pages 10 - 13

BOLT & BELT TORQUE CHART.....Page 14

WARRANTY POLICY/PROCEDURE.....Page 15

COPY OF WARRANTY CLAIM.....Page 16

COPY OF DEALER DELIVERY REPORT & WARRANTY CARD.....Page 17

SERVICE SCHEDULE LOG.....Page 18

09/05
SALSCO, INC.
105 School House Rd., Cheshire, CT 06410
800-872-5726, 203-271-1682, 203-271-2596(Fax)
sales@salsco.com, www.salsco.com

STATEMENT OF FACT

You have just purchased the highest quality and most dependable Chipper on the market today. This unit has the ability to meet exact standards and perform for years with minimum downtime. **However, it cannot read nor will it understand this manual no matter how long you leave it on top of the machine.** It is your responsibility to read and understand this manual; it is also your responsibility to be certain this information is passed along to anyone who is expected to operate this equipment. Should you choose not to read, understand and pass along the information provided you, please expect equipment failure and possible injuries to persons around this equipment.

For the safety of the operator, it is imperative that this manual is carefully read and understood.

Once you have read this manual, it is your responsibility to be sure that all new operators read and understand this manual, especially all cautions stated.

As a manufacturer of equipment, we have a responsibility to design a safe piece of equipment.

NOTE: The important safeguards and instructions in this manual are not meant to cover all possible conditions and situations that may occur. It must be understood that **common sense, caution, and care are factors, which cannot be built into any product.** These factors must be supplied by the person(s) caring for and operating this equipment.

ONLY YOU CAN PREVENT ACCIDENTS!!

SPECIFICATIONS & FEATURES

The Salsco 608,610 or 616, is a 3-1/2" capacity, gravity feed Chipper, that is just right for yard clean up jobs. Designed and engineered for doing heavy work, not just chipping a few small branches and mulching leaves.

The extra high 4-1/4" opening, by 3-1/2", means less pruning of branchy, stringy material. This unit has a 1/2" thick, sharpenable, replaceable, and adjustable bed knife to provide consistent chip size and the ability to chip even the stringiest, brushiest materials. The 13" diameter impeller is 1" thick, and the four exhaust paddles are fully gusseted to provide years of use. All bearings are heavy duty, greasable and self-centering. There are two 3/8" thick, oil hardened, chip blades.

The infeed hopper opening is wide and will accept bushy branches. Gravity feed makes it easy to run material through the chipping disc. The exhaust chute easily fits over the standard trash can or even a 30-Gallon container for easy debris removal.

Available as an option, the Transport Wheel Kit, makes the unit easy to tow on the road. A 2" ball coupler and tow chains are also provided with the kit.

Quality of Workmanship, Innovative Design, Built to Last!

MACHINE REGISTRATION

MANUFACTURED BY:

SALSCO, INC.

105 School House Rd., Cheshire, CT 06410

800-872-5726, 203-271-1682, 203-271-2596 (Fax)

sales@salsco.com www.salsco.com

THIS MANUAL COVERS MODEL (s): 608, 610 & 616 CHIPPER

This company reserves the right to discontinue, add improvements to, or change the design of any model or product at any time without obligation to improve existing machines, either by changing the design or adding new parts.

It has been and will continue to be the policy of SALSCO to update existing machines at its own discretion. Whenever possible, new designs will be made in such a way that they can be "Retro Fit" if so desired.

Record in the space provided below the model and serial number of this unit. Please retain these numbers for future reference.

No parts orders will be accepted **WITHOUT MODEL NUMBERS OR PART NUMBERS**. All part numbers are listed in this manual.

Serial Number _____ Model Number _____

NOTE: Be sure to complete your warranty card. This will insure immediate processing of any warranty claims.

READ AND UNDERSTAND THIS MANUAL BEFORE STARTING MACHINE

BRUSH CHIPPERS ANSI Z133.1-2006

American National Standard for Arboricultural Operations Safety Requirements

5.3 Brush Chippers

- 5.3.1 The items contained in section 5.1 shall always be included in the review of this section.
- 5.3.2 Access panels (for example, guards) for maintenance and adjustment, including discharge chute and cutter housing, shall be closed and secured prior to starting the engine of brush chippers. These access panels shall not be opened or unsecured until the engine and all moving parts have come to a complete stop (see Annex C, General Safety Procedures That Apply to All Tree Work).
- 5.3.3 Rotary drum or disc brush chippers not equipped with a mechanical infeed system shall be equipped with an infeed hopper not less than 85 inches (2.15 m) measured from the blades or knives to ground level over the center line of the hopper. Side members of the infeed hopper shall have sufficient height so as to prevent workers from contacting the blades or knives during operations.
- 5.3.4 Rotary drum or disc brush chippers not equipped with a mechanical infeed system shall have a flexible anti-kickback device installed in the infeed hopper to reduce the risk of injury from flying chips and debris.
- 5.3.5 Chippers equipped with a mechanical infeed system shall have a quick-stop and reversing device on the infeed system. The activating mechanism for the quick-stop and reversing device shall be located across the top, along each side, and close to the feed end of the infeed hopper within easy reach of the worker.
- 5.3.6 Vision, hearing, and/or other appropriate personal protective equipment shall be worn when in the immediate area of a brush chipper in accordance with section 3.4, Personal Protective Equipment.
- 5.3.7 Arborists, mechanics, and other workers shall not, under any circumstances, reach into the infeed hopper when the cutter disc, rotary drum, or feed rollers are moving.
- 5.3.8 When trailer chippers are detached from the vehicles, they shall be chocked or otherwise secured in place.
- 5.3.9 When in a towing position, chipper safety chains shall be crossed under the tongue of the chipper and properly affixed to the towing vehicle.
- 5.3.10 See section 8.6, Brush Removal and Chipping, for additional requirements.

BRUSH REMOVAL AND CHIPPING ANSI Z133.1-2006

American National Standard for Arboricultural Operations Safety Requirements

8.6 Brush Removal and Chipping

- 8.6.1 Traffic control around the jobsite shall be established prior to the start of chipping operations along roads and highways (see section 3.2, Traffic Control Around the Jobsite).
- 8.6.2 Brush and logs shall not be allowed to create hazards in the work areas.
- 8.6.3 To prevent an entanglement hazard, loose clothing, climbing equipment, body belts, harnesses, lanyards, or gauntlet-type gloves (for example, long-cuffed lineman's or welder's gloves) shall not be worn while operating chippers.
- 8.6.4 Personal protective equipment shall be worn when in the immediate area of chipping operations in accordance with section 3.4, Personal Protective Equipment, of this standard.
- 8.6.5 Training shall be provided in the proper operation, feeding, starting, and shutdown procedures for the chipper being used.
- 8.6.6 Maintenance shall be performed only by those persons authorized by the employer and trained to perform such operations.
- 8.6.7 Brush and logs shall be fed into chippers, butt or cut end first, from the side of the feed table center line, and the operator shall immediately turn away from the feed table when the brush is taken into the rotor or feed rollers. Chippers should be fed from the curb-side whenever practical.
- 8.6.8 The brush chipper discharge chute or cutter housing cover shall not be raised or removed while any part of the chipper is turning or moving. Chippers shall not be used unless a discharge chute of sufficient length or design is provided that prevents personal contact with the blades (see Annex C, General Safety Procedures That Apply to All Tree Work).
- 8.6.9 Foreign material, such as stones, nails, sweepings, and rakings, shall not be fed into chippers.
- 8.6.10 Small branches shall be fed into chippers with longer branches or by being pushed with a long stick.
- 8.6.11 Hands or other parts of the body shall not be placed into the infeed hopper. Leaning into or pushing material into infeed hoppers with feet is prohibited.
- 8.6.12 While material is being fed into the chipper infeed hopper chute, pinch points continually develop within the material being chipped and between the material and machine. The operator shall be aware of this situation and respond accordingly.
- 8.6.13 When feeding a chipper during roadside operations, the operator shall do so in a manner that prevents him or her from stepping into traffic or being pushed into traffic by the material that is being fed into the chipper.
- 8.6.14 When using a winch in chipper operations, the operator shall ensure that the winch cable is properly stored before initiating chipper operations.
- 8.6.15 Refer to section 5.3, Brush Chippers, for additional information.

OPERATING INSTRUCTIONS

1. Be sure the machine is on a **CLEAN FLAT SURFACE**.
2. Check engine oil and fuel levels, as per engine manufacturer's specifications.
3. **NEVER** let anyone under the age of 18 operate this machine.
4. Start engine and let it run at idle for a few minutes to warm-up.
5. Set engine throttle to full RPM.
6. Prune branches and put them into the infeed hopper.

DO NOT REACH INTO THE MACHINE FOR ANY REASON!

7. If there is a branch that will not fit, pull it out.
8. If the branch is down inside the hopper:
 - A) **SHUT DOWN THE ENGINE**.
 - B) Reach in and pull out the branch **AFTER ALL MOVING PARTS HAVE STOPPED**.
 - C) Let machine run a few minutes at full RPM and a few minutes at idle to be sure that the hopper is all clear of wood and the engine has cooled.

CAUTION! NEVER PUT FUEL INTO A HOT ENGINE. BE SURE TO WAIT UNTIL ENGINE HAS FULLY COOLED DOWN BEFORE RE-FUELING!

REMEMBER! A CHIPPER WILL ONLY LET YOU MAKE A STUPID MISTAKE ONCE!

SERVICE & MAINTENANCE INSTRUCTIONS

1. See your Engine Manual for service instructions on the engine.
2. **NEVER** let anyone under the age of 18 operate the machine.
3. Be sure to check engine oil daily.
4. Be sure to grease the machine once a day.
5. Start the engine and let it run at idle for a few minutes to warm-up.
6. When the chipper will no longer pull wood in by itself, the blades need to be sharpened.

SHARPENING

1. Remove the spark plug wire and turn the on-off switch to off.
2. Remove the infeed hopper, three (3) bolts.
3. Pull the rope slowly till the chip blade is in the window.
4. Remove the screws holding the blades onto the impeller.
5. Sharpen or replace the blades. **We suggest replacing the screws each time you re-install blades.**
6. Be sure to clean the mounting surface and make sure that the blade fits right onto the impeller.
7. **Use Loctite** when replacing blades. Salsco uses **Loctite, Blue 242, Removable** at the factory.
8. After the blades are sharpened or replaced, the bed knife should be checked.
9. Loosen the bed knife bolts. Install the infeed hopper.
10. Rotate the impeller by pulling the rope till the chip blades passes the bed knife.
11. Set the clearance to approximately 3/16" by sliding the bed knife in or out to obtain this dimension.

NOTE: The closer the bed knife to the blade, the slower the machine will feed. The greater the gap, the faster it will feed.

When you finish, double-check the following:

1. Clearance of both chip blades to bed knife.
2. Tightness of bed knife bolts and chip blade bolts.
3. Hopper is bolted back on and bolts are tightened.
4. Replace spark plug wire.

**READ & UNDERSTAND THIS MANUAL BEFORE STARTING
OR SERVICING THIS MACHINE!**

CHIPPER MODEL 608 - MAIN ASSEMBLY

11/03

REVISIONS		
REV	DESCRIPTION	DATE

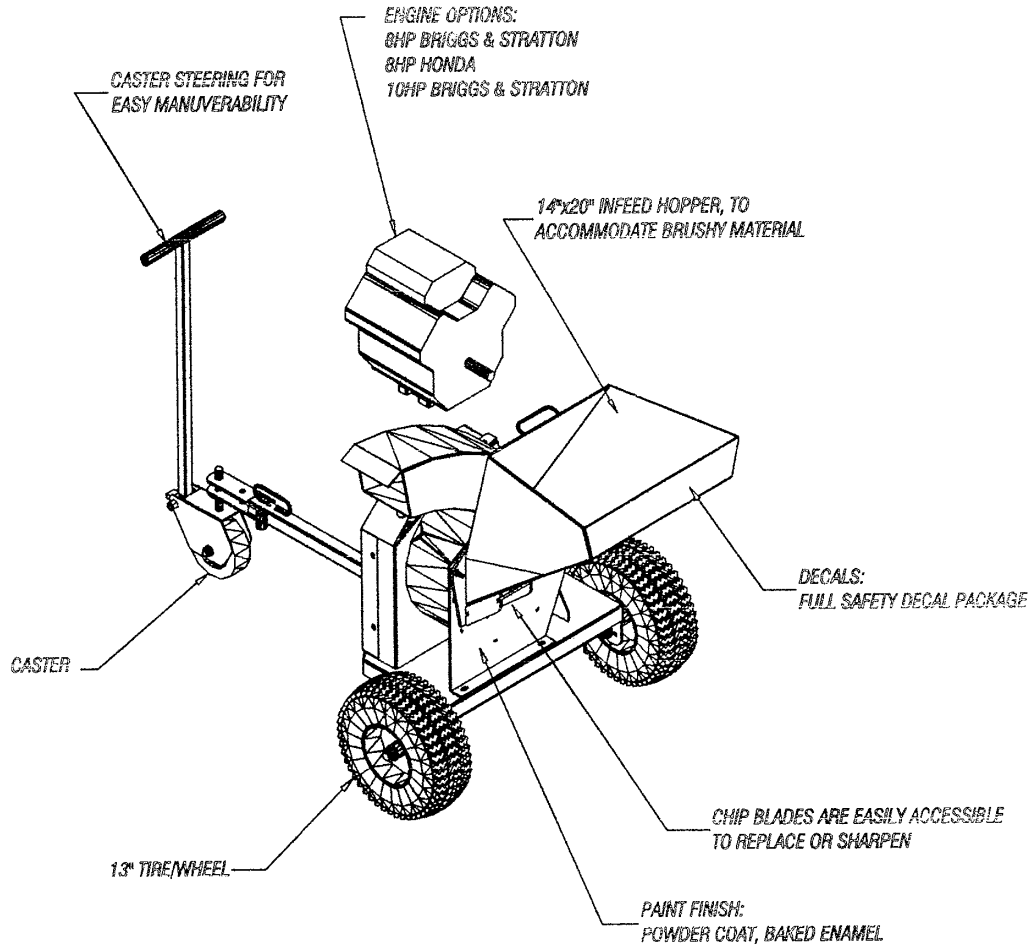

REV	DESCRIPTION	DATE

RE-ISSUE DATE: 02-25-2008

11/03

MODEL 608 - CHIPPER COMPONENTS

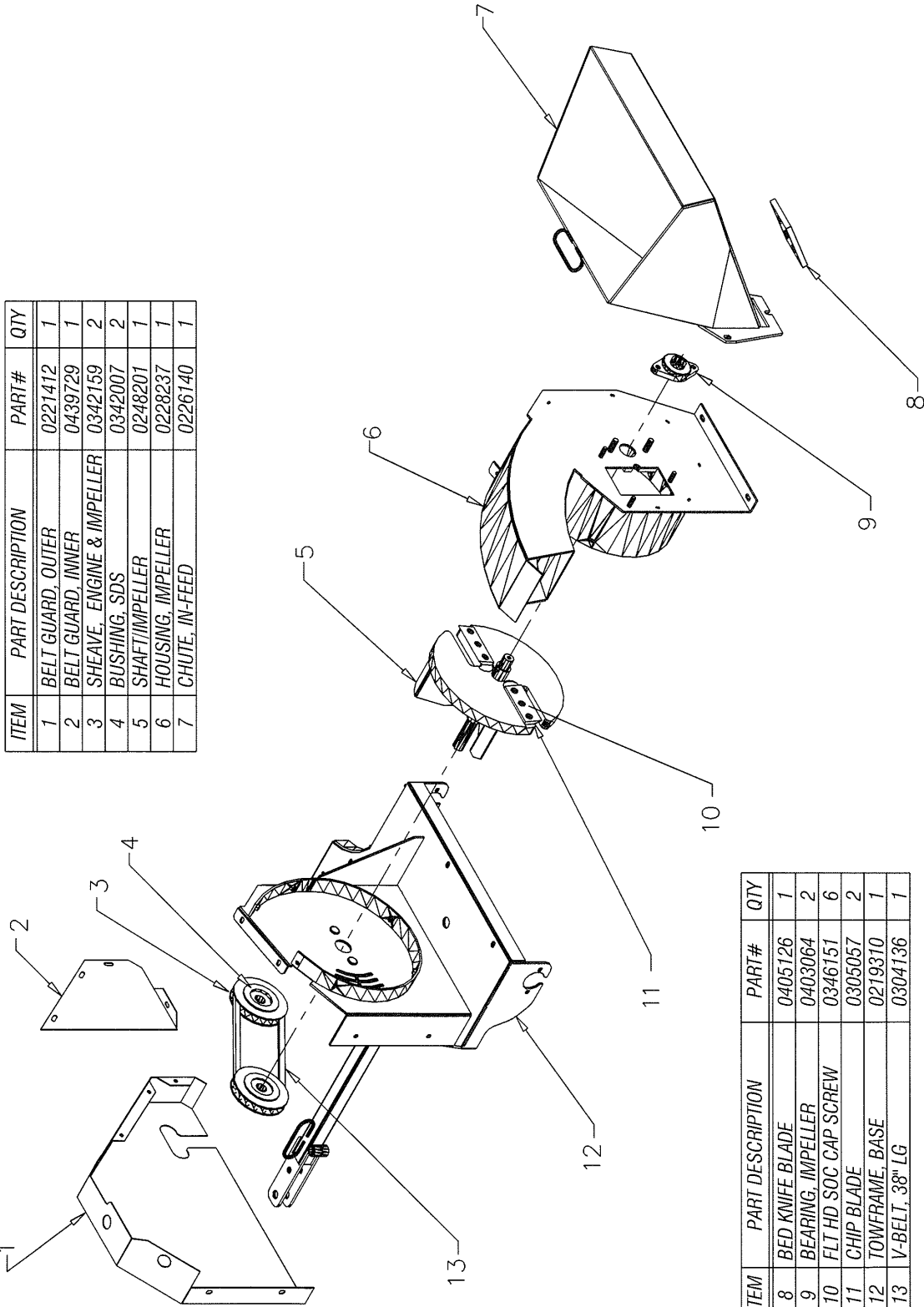

ITEM	PART DESCRIPTION	PART#	QTY
1	BELT GUARD, OUTER	0221412	1
2	BELT GUARD, INNER	0439729	1
3	SHEAVE, ENGINE & IMPELLER	0342159	2
4	BUSHING, SDS	0342007	2
5	SHAFT/IMPELLER	0248201	1
6	HOUSING, IMPELLER	0228237	1
7	CHUTE, IN-FEED	0226140	1

ITEM	PART DESCRIPTION	PART#	QTY
8	BED KNIFE BLADE	0405126	1
9	BEARING, IMPELLER	0403064	2
10	FLT HD SOC CAP SCREW	0346151	6
11	CHIP BLADE	0305057	2
12	TOWFRAME, BASE	0219310	1
13	V-BELT, 38" LG	0304136	1

MODEL 608 - FRAME ON WHEELS 11/03

REVISIONS		
REV	DESCRIPTION	DATE

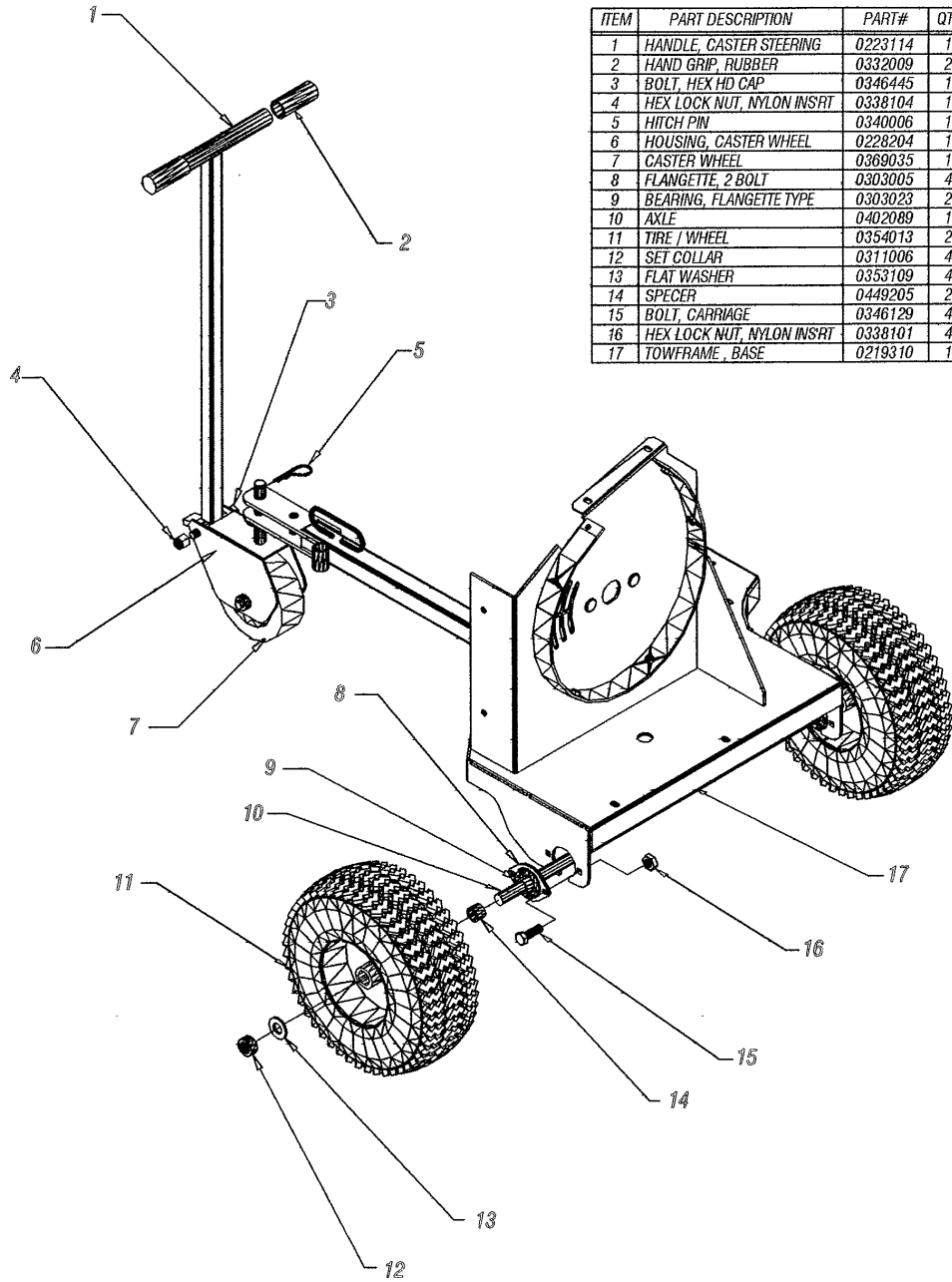

ITEM	PART DESCRIPTION	PART#	QTY
1	HANDLE, CASTER STEERING	0223114	1
2	HAND GRIP, RUBBER	0332009	2
3	BOLT, HEX HD CAP	0346445	1
4	HEX LOCK NUT, NYLON INSRT	0338104	1
5	HITCH PIN	0340006	1
6	HOUSING, CASTER WHEEL	0228204	1
7	CASTER WHEEL	0369035	1
8	FLANGETTE, 2 BOLT	0303005	4
9	BEARING, FLANGETTE TYPE	0303023	2
10	AXLE	0402089	1
11	TIRE / WHEEL	0354013	2
12	SET COLLAR	0311006	4
13	FLAT WASHER	0353109	4
14	SPECER	0449205	2
15	BOLT, CARRIAGE	0346129	4
16	HEX LOCK NUT, NYLON INSRT	0338101	4
17	TOWFRAME, BASE	0219310	1

CHIPPER MODEL 608
 OVER -- THE -- ROAD OPTION # 0161208

11/03

REVISIONS		
REV	DESCRIPTION	DATE

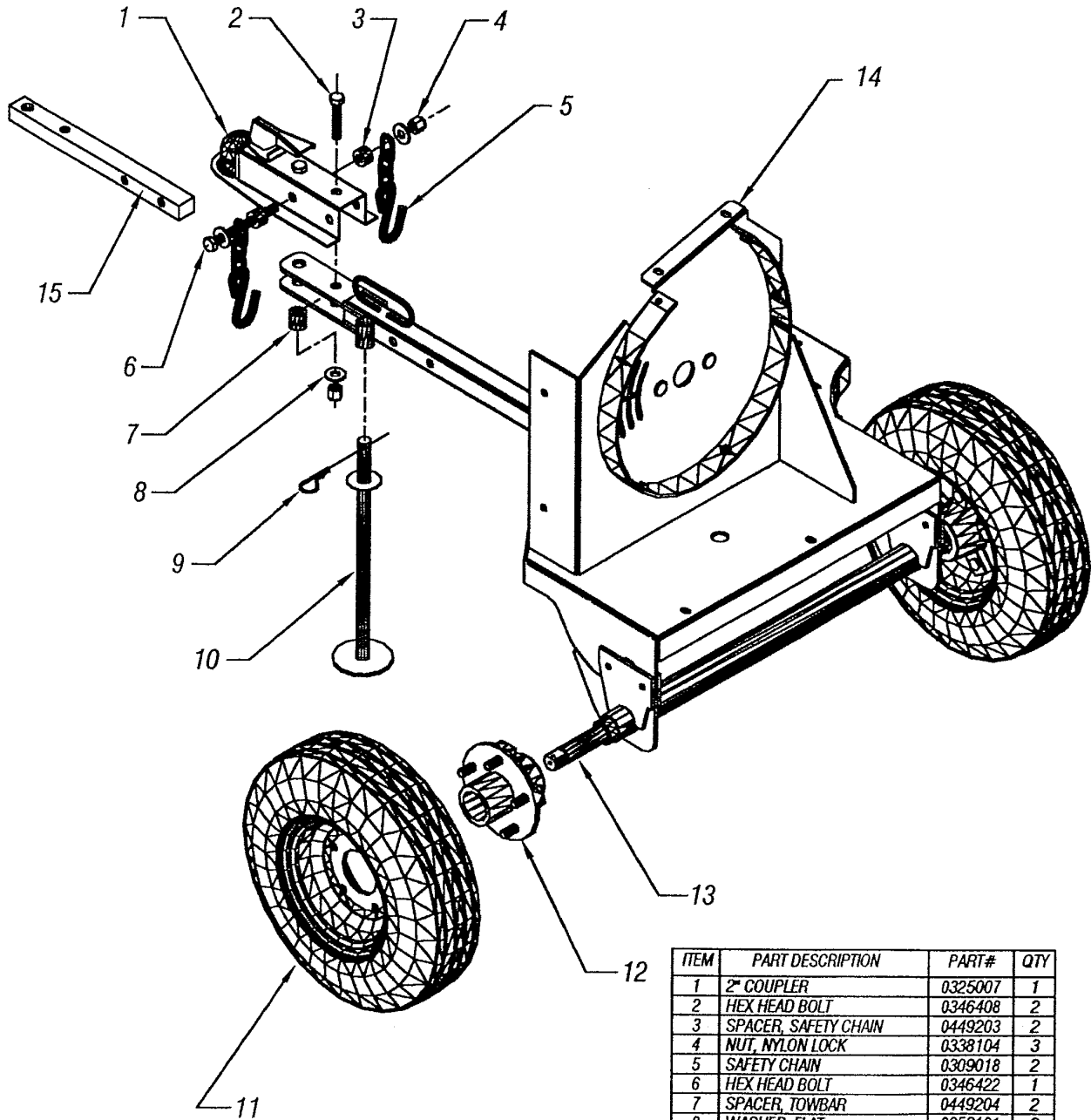

ITEM	PART DESCRIPTION	PART#	QTY
1	2 nd COUPLER	0325007	1
2	HEX HEAD BOLT	0346408	2
3	SPACER, SAFETY CHAIN	0449203	2
4	NUT, NYLON LOCK	0338104	3
5	SAFETY CHAIN	0309018	2
6	HEX HEAD BOLT	0346422	1
7	SPACER, TOWBAR	0449204	2
8	WASHER, FLAT	0353181	2
9	HITCH PIN	0340006	1
10	SUPPORT TONGUE	0277184	1
11	TIRE / WHEEL ASSY	0354016	2
12	WHEEL HUB ASSY	0329002	2
13	AXLE, OVER-THE-ROAD	0202087	1
14	TOWFRAME BASE	0219310	1
15	BAR, TONGUE REINFORCEMENT	0470147	1

Below is a quick reference chart for various "Flat Head Cap Screws" and the torque recommendations.

VALUES ARE STATED IN FOOT POUNDS

BOLT SIZE	Thds Per Inch	SAE Grade 5	SAE Grade 8
1/4	20	10	14
	28	---	---
5/16	18	19	29
	24	---	---
3/8	16	33	47
	24	---	---
7/16	14	54	78
	20	---	---
1/2	13	78	119
	20	---	---
9/16	12	114	169
	18	---	---
5/8	11	154	230
	11	---	---
3/4	10	257	380
	10	---	---
7/8	9	382	600
	9	---	---
1	8	587	700
	8	---	---

Drive Belt Tension Measurement by Deflection

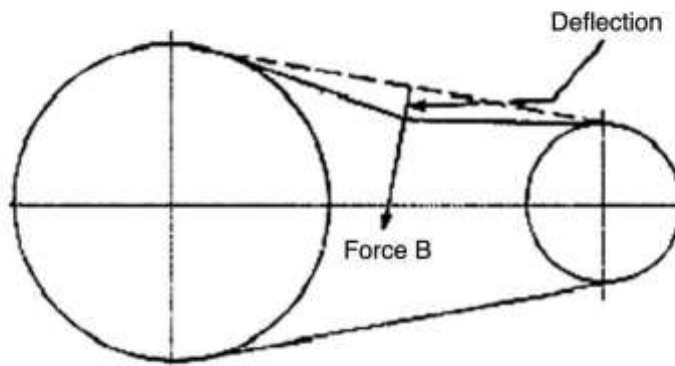

Deflection should be 3/8" when 8-12 lbs. push is applied at "B"

WARRANTY POLICY

Please remember to complete and return your Warranty Card and Dealer Delivery Report. Warranty Claims will not be considered if the Warranty Card and Dealer Delivery Report have not been returned to Salsco.

Your Salsco Commercial or Turf Equipment product is a commercial type product and is normally manufactured and sold for commercial or industrial use. **Salsco will, for the original purchaser, for one (1) year from the date of purchase (90 days if used for rental purposes) repair or replace, free of charge, any SALSCO part or parts found to be defective in material, workmanship or both.** Any transportation or shipping charges will be borne by the purchaser. If, during the warranty period stated above, the product does not function properly due to defect, simply contact Salsco and follow the Warranty Procedures included in this manual.

This warranty **does not** include:

- Incidental or consequential damages and is exclusive of any implied warranties.
- Normal maintenance parts, including, but not limited to hoses, chains, belts, filters, lubricants, etc.
- Parts or components, which are covered under the original manufacturer warranty, including, but not limited to engines, pumps, and motors.

WARRANTY PROCEDURE

In order for Salsco to consider your warranty claims in a timely manner you must follow the simple procedures listed below:

MACHINE OR PART FAILURE

- Call our service department for helpful instruction on how to correct or repair the problem. Preventive maintenance will also be suggested.
- When ordering parts for Warranty issues, you **MUST** retain possession of the old parts in question until notified with respect to returning the parts to Salsco or other disposition.
- Warranty Claims **MUST** be filed within 30-days from completion of the work performed. Contact our office for an electronic warranty claim form.
- Fill in all information requested on warranty claim form, a copy of which is included in this manual, (date of purchase, company name, address, etc.). List all parts used. Make sure part numbers are correct. You can obtain these from your manual. (include good description of problem; i.e. "leaking from spool" rather than "leaking").
- It is our goal to consider and reach a disposition on each Warranty Claim within 30-days from the date that it is received. Therefore it is important that you respond promptly to any request for further information. Claims with no response to inquiries will be closed as "**denied for lack of response**" 90-days from the date of request.
- Email, Fax or Send Warranty Claim form to our Warranty Department. – **Warranty on parts most often requires return of the parts that were replaced. DO NOT DISCARD OLD PARTS UNTIL YOU HAVE RECEIVED A DETERMINATION AS TO WHETHER THESE PARTS MUST BE RETURNED.**
- Our Warranty Department will contact and instruct you on how to return the Parts to Salsco on an RA #. Returns **MUST** be made within 30-Days from issuance of RA #. **FREIGHT CHARGES ON RETURN OF PARTS IS THE RESPONSIBILITY OF THE CUSTOMER.** Normal pre-delivery adjustments are not covered under warranty. Labor Warranties are based on reasonable time allowances as determined by Salsco, Inc. and paid at 75% of posted labor rate. **TRAVEL TIME IS NOT REIMBURSED UNDER THE WARRANTY POLICY.**
- Be sure to put the RA form inside the box that you are shipping back, also be sure to put on the outside of the box "Return of Goods" and the RA #.
- Ship returns via a traceable method such as UPS Ground Service. Be sure that the shipment is insured for the appropriate value. If uninsured parts are lost, we cannot issue a credit.

PLEASE NOTE: *Warranty forms should be filled out completely.*

PREVENTIVE MAINTENANCE IS YOUR BEST INSURANCE AGAINST EQUIPMENT FAILURE. BE SURE TO READ THIS MANUAL, ESPECIALLY THE MAINTENANCE, OPERATING AND CAUTION SECTIONS.

SALSCO, INC., 105 School House Rd.
Cheshire, CT 06410
800-872-5726, 203-271-1682
203-271-2596 (Fax)
sales@salsco.com, www.salsco.com

Salsco, Inc.

105 School House Rd.
Cheshire, CT 06410
203-271-1682

sales@salsco.com
www.salsco.com

800-872-5726
203-271-2596 (Fax)

DEALER DELIVERY REPORT

MODEL		SERIAL NO				
DEALER		CITY	STATE	ZIP		
PURCHASER (Last Name or Company)	(First Name)	(Middle Name)	ADDRESS	CITY	STATE	ZIP

The undersigned dealer warrants that the above-described machine was carefully inspected, adjusted and prepared for delivery before delivery to the purchaser; that both the operation and maintenance of the machine were explained to the purchaser; and that a copy of the Owner's Instruction Manual were given to the purchaser and his attention called to Our Warranty and any operating instructions included in the manual and caution notes.

Date _____ Dealer _____

Sign By _____

Phone _____

The undersigned purchaser certifies that the operation and maintenance of the above-described machine have been explained to him; acknowledges receipt of a copy of the Owners's Instruction Manual and Our Warranty Policy printed in said Instruction Manual and Caution Notes. I also understand that it is my responsibility to explain and make Salsco manuals available to new operators.

Date _____ Purchaser _____

Sign By _____

Phone _____

Email _____

FACTORY COPY WHITE - DEALER'S COPY YELLOW - OWNER'S COPY PINK

SERIAL #

MODEL NO.

SALSCO LIMITED WARRANTY CARD

1. DATE PURCHASED: _____
2. PURCHASER: _____
3. PURCHASER ADDRESS: _____

4. EMAIL ADDRESS: _____
5. DEALER: _____
6. DEALER ADDRESS: _____
7. WILL THIS EQUIPMENT BE USED COMMERCIALY? YES NO
8. DID DEALER SERVICE THIS EQUIPMENT AND INSTRUCT YOU IN ITS CARE AND SAFE OPERATION ? YES NO
9. DID YOU RECEIVE AN "OPERATION & SERVICE MANUAL" AND SAFETY PAMPHLET? YES NO

NOTICE

SIGNED _____
Purchaser

IMPORTANT: THIS CARD MUST BE FILLED OUT COMPLETELY AND MAILED TO THE FACTORY WITHIN 10 DAYS OF PURCHASE DATE, OR YOUR LIMITED WARRANTY WILL BE VOIDED.

WHITE - DEALER

YELLOW - OWNER

CARD - FACTORY

