

**Salsco, INC.**  
LEADER BY DESIGN

MADE IN THE U.S.A

## OPERATORS AND PARTS MANUAL MODELS 525T AND 525 STRAWBLOWER



**MANUFACTURER OF OUTDOOR POWER EQUIPMENT**

Products for Turf & Lawncare, Rental, Construction, Tree care, Wood Processing, Nursery & Farm Industries

*Other Salsco Equipment*

**3-1/2" - 18", Gas, Diesel, and P.T.O, Wood/Brush Chippers**

**Chipper Shredder Vacuum - Tailgate & Truckloader Vacuums up to 65 HP**

**Shaving Mills - Gas and Electric Greens Rollers**

*Quality of Workmanship, Innovative  
Design, Built to Last!*

105 School House Road  
Cheshire, CT 06410 U.S.A.  
800-872-5726, 203-271-1682, 203-271-2596 (Fax)  
sales@salsco.com, www.salsco.com

**TABLE OF CONTENTS**

**MODEL (S) 525 STRAWBLOWER & 525T STRAWBLOWER**

COVER & TABLE OF CONTENTS.....Pages 1 – 2

STATEMENT OF FACT ..... Page 3

MACHINE REGISTRATION .....Page 4

PARTS DIAGRAMS .....Pages 5 - 8

TORQUE CHARTS .....Page 9

WARRANTY POLICY/PROCEDURE .....Page 10

COPY OF WARRANTY CLAIM FORM.....Page 11

COPY OF DEALER DELIVERY REPORT & WARRANTY CARD.....Page 12

SERVICE SCHEDULE LOG .....Page 13

SALSCO, INC.  
105 School House Road  
Cheshire, CT 06410  
800-872-5726, 203-271-1682  
203-271-2596 (Fax)

## **STATEMENT OF FACT**

You have just purchased the highest quality, most dependable, Strawblower on the market today. This unit has the ability to meet exact standards and perform for years with minimum downtime. HOWEVER, it cannot read nor will it understand this manual no matter how long you leave it on top of the machine.

**It is your responsibility** to read and understand this manual; it is also your responsibility to be certain this information is passed along to anyone who is expected to operate this equipment. Should you choose not to read, understand and pass along the information provided you, please expect equipment failure and possible injuries to persons around this equipment.

For the safety of the operator, it is **imperative** that this manual is carefully read and understood.

Once you have read this manual, it is your responsibility to be sure that all new operators read and understand this manual, especially all cautions stated.

As a manufacturer of equipment, we have a responsibility to design a safe piece of equipment. NOTE: The important safeguards and instructions in this manual are not meant to cover all possible conditions and situations that may occur. It must be understood that common sense, caution, and care are factors, which cannot be built into any product. These factors must be supplied by the person(s) caring for and operating this equipment.

**ONLY YOU CAN PREVENT ACCIDENTS!!**



# TRAILER ASSEMBLY

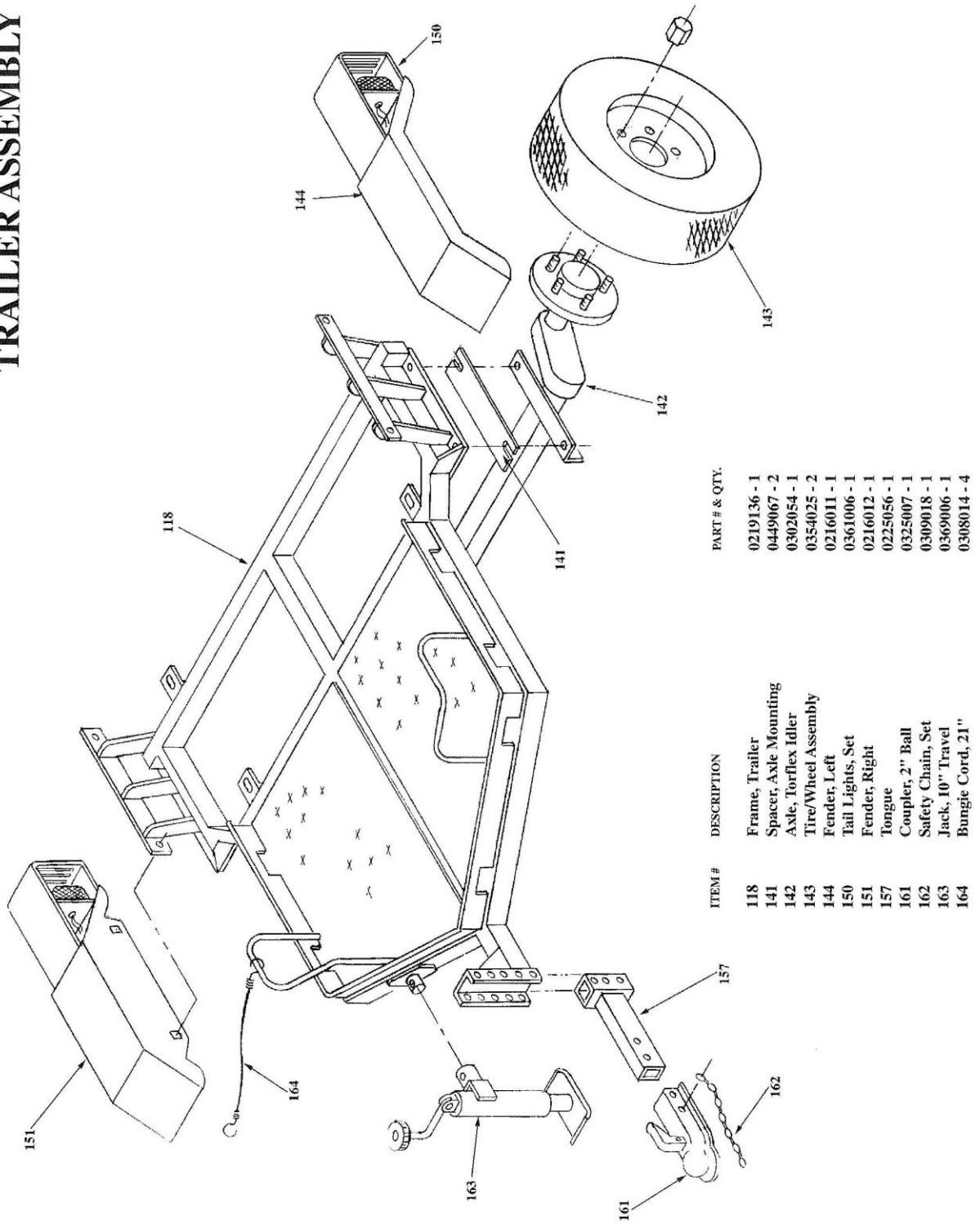

## SLIDE DOOR ASSEMBLY

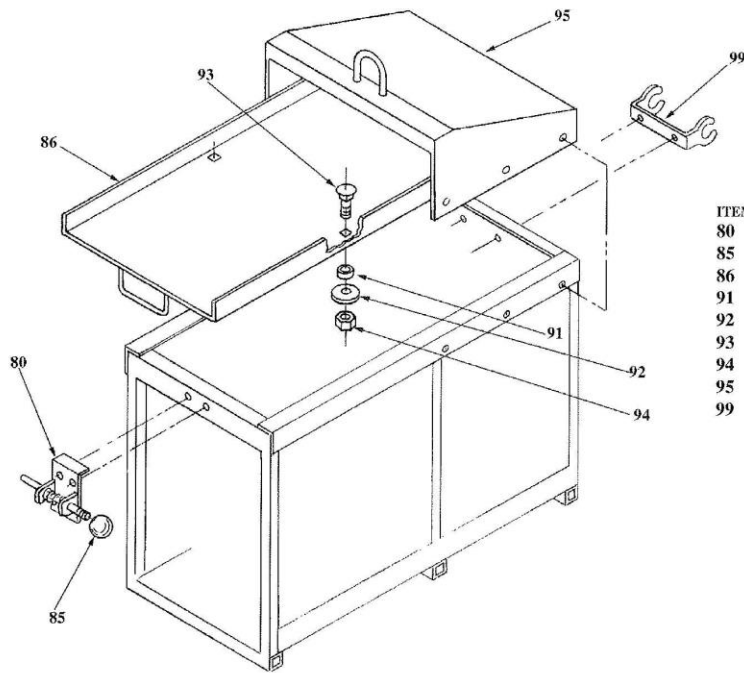

ITEM #	DESCRIPTION	PART # & QTY.
80	Latch, Cover Slide	0133083 - 1
85	Knob	0332005 - 1
86	Cover, Slide	0171099 - 1
91	Spacer	0449090 - 4
92	Washer, Special	H166 - 4
93	Bolt, Carriage	0346429 - 4
94	Nut, Hex Lock	0338104 - 4
95	Cover, Hopper Top	0271093 - 1
99	Holder, Manual Tube	0481029 - 1

## HOSE/EXHAUST ASSEMBLY

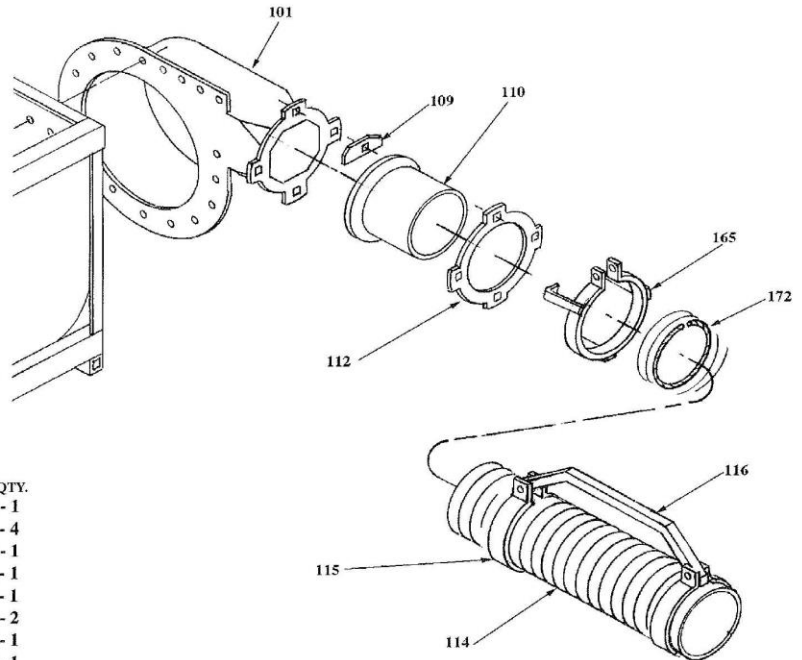

ITEM #	DESCRIPTION	PART # & QTY.
101	Housing, Impeller	0228158 - 1
109	Spacer, Blower	N135 - 4
110	Tube, Discharge Adapter	0267149 - 1
112	Tube, Mounting Ring	D239 - 1
114	Hose, Corrugated 8"	0327113 - 1
115	Clamp, 8" Hose	0410087 - 2
116	Handle, 8" Hose	0423052 - 1
165	Hose, Retainer	0210093 - 1
172	Spacer, 3/8 x 29 Cord	0308028 - 1

# HOUSING ASSEMBLY

ITEM #	DESCRIPTION	PART # & QTY.
2	Main Frame	0219208 - 1
30	Clamp, Battery	0410028 - 1
31	Battery, 12 Volt	0336008 - 1
32	Terminal Lugs	0315022 - 4
33	Cable, Battery, Red	0315006 - 1
34	Cable, Battery, Black	0215006 - 1
37	Cover, Belt, Left	0471089 - 1
38	Cover, Belt, Right	0471090 - 1
39	Tank, Fuel	0352006 - 1
40	Fitting, Quick Disconnect	0317084 - 1
41	Fitting, Quick Disconnect	0317085 - 1
42	Fuel Line	0327055 - 1
43	Clamp, Spring	0310035 - 2
44	Cord, Bungie	0308018 - 1
45	Engine, 25 HP Kohler	0337048 - 1
46	Muffler, Kohler	0337050 - 1
47	Basket, Muffler	0337049 - 1
48	Clamp, Muffler	0304108 - 1
49	Deflector, Muffler	0337041 - 1
167	Hose, Oil Drain Extension	0127117 - 1

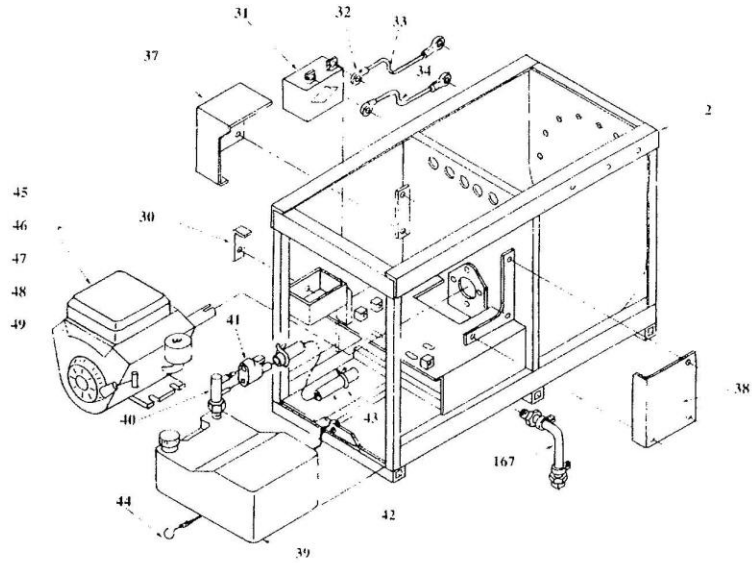

# SHAFT/IMPELLER ASSEMBLY

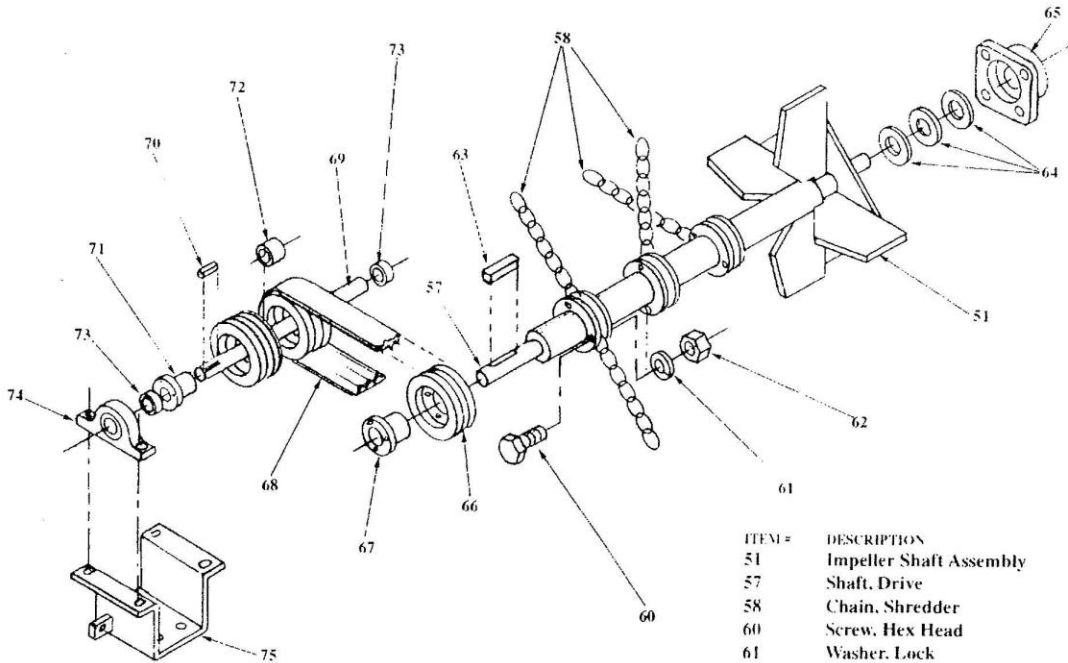

ITEM #	DESCRIPTION	PART # & QTY.
51	Impeller Shaft Assembly	0248101 - 1
57	Shaft, Drive	0448103 - 1
58	Chain, Shredder	0309046 - 6
60	Screw, Hex Head	0346304 - 6
61	Washer, Lock	0353004 - 6
62	Nut, Hex Lock	0338103 - 6
63	Key, 3/8" Sq. x 2"	0331205 - 2
64	Spacer	0449091 - 3
65	Bearing, 4-Bolt Flange	0303042 - 2
66	Sheave, 3 Groove	0342089 - 4
67	Bushing SD-1 7/16	0342034 - 2
68	Belt, Banded 38"	0304063 - 2
69	Shaft, Jack	0448104 - 1
70	Key, 1/4" Sq. x 1 3/4"	0331116 - 2
71	Bushing, SD-1"	0342090 - 2
72	Spacer, Jack Shaft, Center	0449093 - 1
73	Spacer, Jack Shaft, End	0449094 - 2
74	Bearing, Pillow Block	0303003 - 2
75	Bracket, Idler Sheave	0206414 - 1

## SWIVEL TURRET OPTION (Part # 0161114)

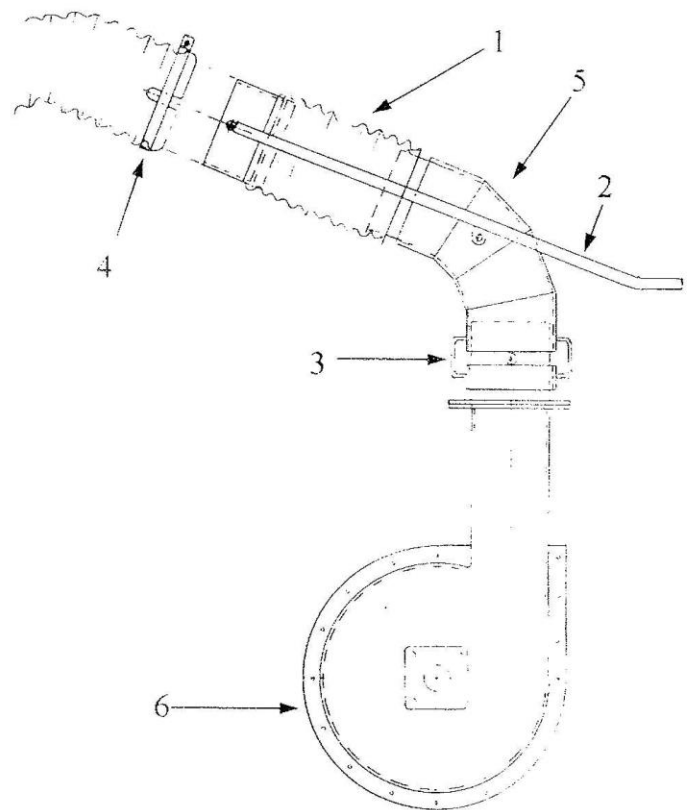

ITEM #	DESCRIPTION	PART # & QTY.
1	Hose, 8" Dia x 24"	0327122 - 1
2	Handle, Turret Opt.	0223072 - 1
3	Rotational Discharge	0226104 - 1
4	Clamp, 8"	0410098 - 1
5	Swivel, 90°	0226105 - 1
6	Blower Housing, Turret Opt.	0228200 - 1

NOTE: Drawing shows the Standard Hose, Part # 0327113, which can be used along with the Turret Assembly. This is not necessary, just optional.



Below is a quick reference chart for various “Flat Head Cap Screws” and the torque recommendations.

**VALUES ARE STATED IN FOOT POUNDS**

BOLT SIZE	Thds Per Inch	SAE Grade 5	SAE Grade 8
1/4	20	10	14
	28	---	---
5/16	18	19	29
	24	---	---
3/8	16	33	47
	24	---	---
7/16	14	54	78
	20	---	---
1/2	13	78	119
	20	---	---
9/16	12	114	169
	18	---	---
5/8	11	154	230
	11	---	---
3/4	10	257	380
	10	---	---
7/8	9	382	600
	9	---	---
1	8	587	700
	8	---	---

Drive Belt Tension Measurement by Deflection

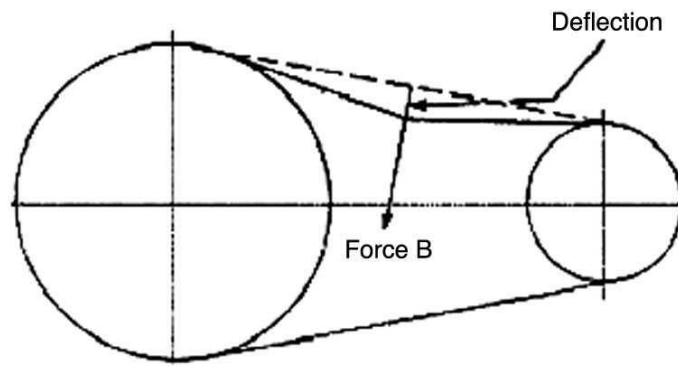

Deflection should be 3/8" when 8-12 lbs. push is applied at "B"

## **WARRANTY POLICY**

***Please remember to complete and return your Warranty Card and Dealer Delivery Report. Warranty Claims will not be considered if the Warranty Card and Dealer Delivery Report have not been returned to Salsco.***

Your Salsco Commercial or Turf Equipment product is a commercial type product and is normally manufactured and sold for commercial or industrial use. **Salsco will, for the original purchaser, for one (1) year from the date of purchase (90 days if used for rental purposes) repair or replace, free of charge, any SALSCO part or parts found to be defective in material, workmanship or both.** Any transportation or shipping charges will be borne by the purchaser. If, during the warranty period stated above, the product does not function properly due to defect, simply contact Salsco and follow the Warranty Procedures included in this manual.

This warranty **does not** include:

- Incidental or consequential damages and is exclusive of any implied warranties.
- Normal maintenance parts, including, but not limited to hoses, chains, belts, filters, lubricants, etc.
- Parts or components, which are covered under the original manufacturer warranty, including, but not limited to engines, pumps, and motors.

## **WARRANTY PROCEDURE**

In order for Salsco to consider your warranty claims in a timely manner you must follow the simple procedures listed below:

### MACHINE OR PART FAILURE

- Call our service department for helpful instruction on how to correct or repair the problem. Preventive maintenance will also be suggested.
- When ordering parts for Warranty issues, you **MUST** retain possession of the old parts in question until notified with respect to returning the parts to Salsco or other disposition.
- Warranty Claims **MUST** be filed within 30-days from completion of the work performed. Contact our office for an electronic warranty claim form.
- Fill in all information requested on warranty claim form, a copy of which is included in this manual, (date of purchase, company name, address, etc.). List all parts used. Make sure part numbers are correct. You can obtain these from your manual. (include good description of problem; i.e. "leaking from spool" rather than "leaking").
- It is our goal to consider and reach a disposition on each Warranty Claim within 30-days from the date that it is received. Therefore it is important that you respond promptly to any request for further information. Claims with no response to inquiries will be closed as "**denied for lack of response**" 90-days from the date of request.
- Email, Fax or Send Warranty Claim form to our Warranty Department. – **Warranty on parts most often requires return of the parts that were replaced. DO NOT DISCARD OLD PARTS UNTIL YOU HAVE RECEIVED A DETERMINATION AS TO WHETHER THESE PARTS MUST BE RETURNED.**
- Our Warranty Department will contact and instruct you on how to return the Parts to Salsco on an RA #. Returns **MUST** be made within 30-Days from issuance of RA #. **FREIGHT CHARGES ON RETURN OF PARTS IS THE RESPONSIBILITY OF THE CUSTOMER.** Normal pre-delivery adjustments are not covered under warranty. Labor Warranties are based on reasonable time allowances as determined by Salsco, Inc. and paid at 75% of posted labor rate. **TRAVEL TIME IS NOT REIMBURSED UNDER THE WARRANTY POLICY.**
- Be sure to put the RA form inside the box that you are shipping back, also be sure to put on the outside of the box "Return of Goods" and the RA #.
- Ship returns via a traceable method such as UPS Ground Service. Be sure that the shipment is insured for the appropriate value. If uninsured parts are lost, we cannot issue a credit.

**PLEASE NOTE:**     *Warranty forms should be filled out completely.*

**PREVENTIVE MAINTENANCE IS YOUR BEST INSURANCE AGAINST EQUIPMENT FAILURE. BE SURE TO READ THIS MANUAL, ESPECIALLY THE MAINTENANCE, OPERATING AND CAUTION SECTIONS.**

SALSCO, INC., 105 School House Rd.  
Cheshire, CT 06410  
800-872-5726, 203-271-1682  
203-271-2596 (Fax)  
sales@salsco.com, [www.salsco.com](http://www.salsco.com)

**WARRANTY CLAIM FORM**

SALSCO, INC.  
105 School House Rd.  
Cheshire, CT 06410

Phone:(203) 271-1682,(800) 872-5726  
Fax: (203) 271-2596  
Email: s.clark@salsco.com  
Website: www.salsco.com

**END OWNER**

Date Submitted:

Name:	Phone:	Work Order #:
Email:	Fax:	Office Use Only
Address:		Date Rec'd
		Cust ID:
		Salsco WC
		Salsco RA

**PURCHASED FROM**

Name:	Phone:	Date Approved:
Email:	Fax:	Date Rejected:
Address:		Processed By:
		Dir. Del Report on File: YES NO
		Warranty Card on File: YES NO
		Part(s) Total:

**Equipment/Warranty Information (Must be complete)**

Purchase Date:	Invoice #	Date Failed:	Labor Total:
			Total Approved:
Model #:	Serial #:	Repair Date:	Approved/Rejected:
			Name:
Hrs Used:	Primary Use:		Reason for Rejection:
Warranty Claim/Work Order#:			
Was a Salsco Return Authorization # issued for repairs or Return of Parts? YES NO			Suggested Preventative Maint:
Probable Cause of Failure:			

Work Performed/Comments on Repair:

Shop Labor Rate:					Submitted By:			
Total Labor Hours to Repair:					Printed Name:			
Parts Required for repair								
Salsco Part #: Description:					Qty.	Price Each	Total	Inv #
							\$	
							\$	
							\$	
							\$	

Fill in all information requested on warranty claim form.  
**INCOMPLETE FORMS CANNOT BE PROCESSED & WILL BE RETURNED**  
List all parts used. Make sure part numbers are correct. Any parts that you believe to be defective or any parts that break should be retained for possible inspection until after the warranty has been paid or part has been replaced.

SALESMAN ID # \_\_\_\_\_

SALES MANAGER'S NAME \_\_\_\_\_

800-872-5726, 203-271-1682 203-271-2596 (Fax)	<b>SALSCO, INC.</b> 105 School House Road Cheshire, CT 06410	<b>www.salsco.com</b> sales@salsco.com
<b>DEALER DELIVERY REPORT</b>		
MODEL:	SERIAL NO:	
DEALER:	CITY:	STATE: ZIP:
PURCHASER:	ADDRESS:	CITY: ST: ZIP:
<p>The undersigned dealer warrants that the above-described machine was carefully inspected, adjusted and prepared for delivery before delivery to the purchaser; that both the operation and maintenance of the machine were explained to the purchaser; and that a copy of the Owner's Instruction Manual were given to the purchaser and his attention called to Our Warranty and any operating instructions included in the manual and caution notes.</p>		<p>The undersigned purchaser certifies that the operation and maintenance of the above-described machine have been explained to him; acknowledges receipt of a copy of the Owner's Instruction Manual and Our Warranty Policy printed in said Instruction Manual and Caution Notes. I also understand that it is my responsibility to explain and make Salsco manuals available to new operators.</p>
DATE:	DATE: PURCHASER:	
SIGN BY:	SIGN BY:	
PHONE: FAX:	PHONE:	
E-Mail:	EMAIL:	

MODEL:	SERIAL NO:	
<b>SALSCO LIMITED WARRANTY CARD</b>		
DATE PURCHASED:		
PURCHASER:	ADDRESS:	CITY: ST: ZIP:
EMAIL:	PHONE:	
DEALER:	STATE: CT	
Will this equipment be used commercially?	Yes <input type="checkbox"/>	No <input type="checkbox"/>
Did Dealer service this equipment and instruct you in its care and safe operation?	Yes <input type="checkbox"/>	No <input type="checkbox"/>
Did you receive an "Operation & Service Manual" and safety pamphlet?	Yes <input type="checkbox"/>	No <input type="checkbox"/>
Signed _____		Purchaser
<b>NOTICE:</b>	IMPORTANT: THIS CARD MUST BE FILLED OUT COMPLETELY AND MAILED TO THE FACTORY WITHIN 10 DAYS OF PURCHASE DATE, OR YOUR LIMITED WARRANTY WILL BE VOIDED.	

